

# AM6017 – Switch

DC – 26.5 GHz SP4T

## Description

AM6017 is a Single-Pole Four-Throw (SP4T) switch covering the DC to 26.5 GHz frequency range. The positive control device provides low insertion loss, flat frequency response, and high isolation over the operating temperature range of -40C to +85C



## Features

- 2.0 dB Insertion Loss
- +41 dBm Input IP3
- +3.3V to +5V Supply
- +3V to +5V Control
- >30 dB Isolation TYP
- 4mm QFN Package
- -40C to +85C Operation

## Functional Diagram

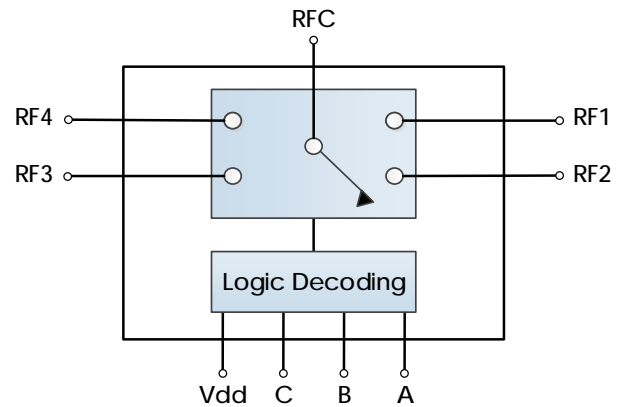

## Characteristic Performance

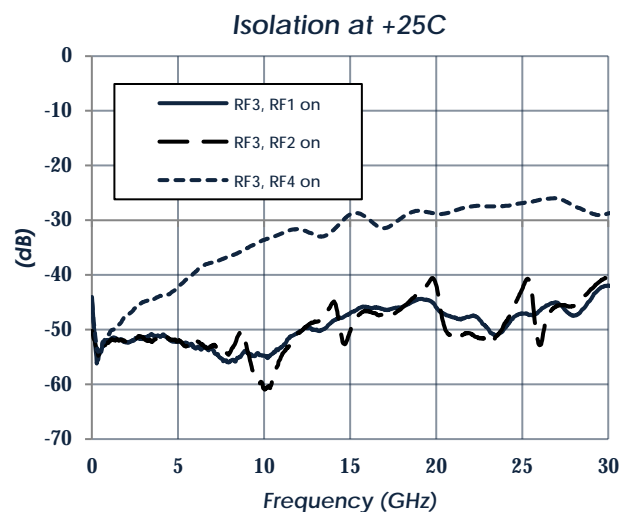
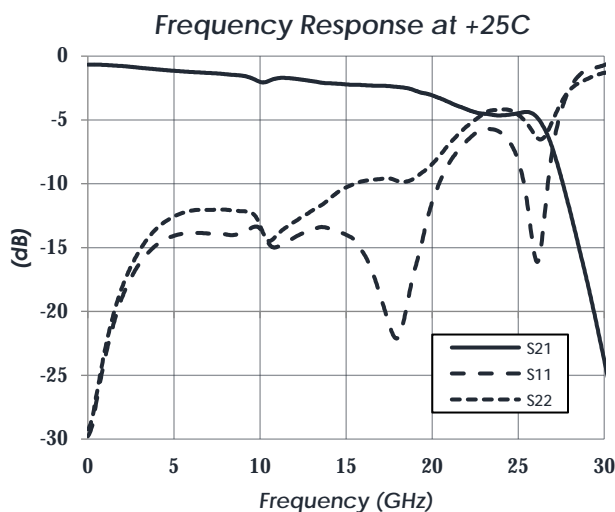

# AM6017 – Switch

DC – 26.5 GHz SP4T

## Table of Contents

Description .....	1	DC Electrical Characteristics.....	5
Features.....	1	RF Performance .....	5
Functional Diagram.....	1	Timing Characteristics .....	5
Characteristic Performance .....	1	State Table .....	5
Revision History .....	2	Typical Performance .....	6
Pin Layout and Definitions.....	3	Typical Application.....	8
Specifications .....	4	Evaluation PC Board .....	9
Absolute Maximum Ratings.....	4	Related Parts.....	9
Handling Information.....	4	Component Compliance Information.....	10
Recommended Operating Conditions....	4		

## Revision History

Date	Revision Number	Notes
August 21, 2018	1	Initial Release
July 15, 2019	2	Various Plots Updated. Package Drawing Corrected.
May 18, 2020	3	Package information moved to main product page

# AM6017 – Switch

DC – 26.5 GHz SP4T

## Pin Layout and Definitions

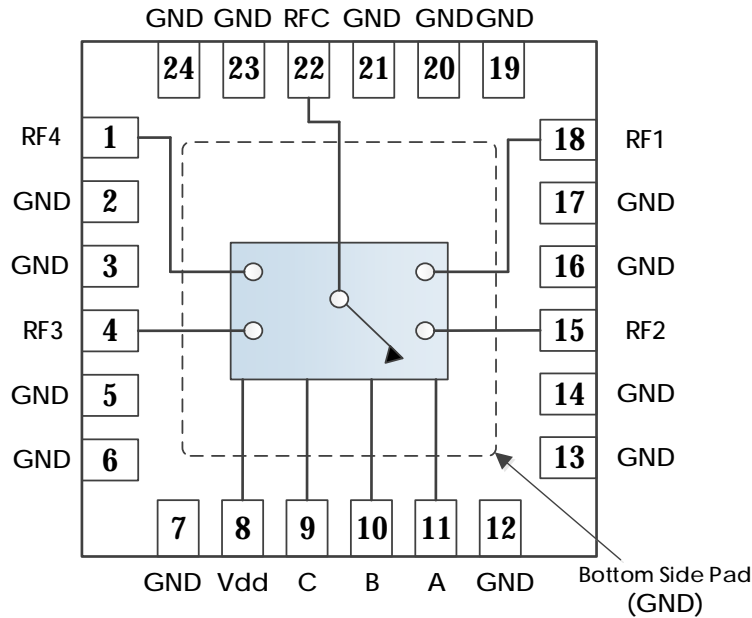

Pin Number	Pin Name	Pin Function
1	RF4	RF4 Output – 50 Ohms – DC Coupled. External DC Blocking Capacitor Required*
2,3	GND	Ground - Common
4	RF3	RF3 Output – 50 Ohms – DC Coupled. External DC Blocking Capacitor Required*
5-7	GND	Ground - Common
8	VDD	DC Power Input
9	C	Switch Control C – Can Be Tied to GND
10	B	Switch Control B
11	A	Switch Control A
12-14	GND	Ground - Common
15	RF2	RF2 Output – 50 Ohms – DC Coupled. External DC Blocking Capacitor Required*
16,17	GND	Ground - Common
18	RF1	RF1 Output – 50 Ohms – DC Coupled. External DC Blocking Capacitor Required*
19-21	GND	Ground - Common
22	RFC	RFC Input – 50 Ohms – DC Coupled. External DC Blocking Capacitor Required*
23,24	GND	Ground - Common
Case GND	GND	Ground - Common

\*Note: DC blocking caps not required if in series with other Atlanta Micro parts of the same reference voltage.

# AM6017 – Switch

DC – 26.5 GHz SP4T

## Specifications

### Absolute Maximum Ratings

	Minimum	Maximum
Supply Voltage	-0.3 V	+6.0 V
RF Input Power		+27 dBm
Operating Junction Temperature	-40 C	+150 C
Storage Temperature Range	-50 C	+150 C

**Note:** Any device operation beyond the Absolute Maximum Ratings may result in permanent damage to the device. The values listed in this table are extremes and do not imply functional operation of the device at these or any other conditions beyond what is listed under Recommended Operating Conditions. Any part subjected to conditions outside of what is recommended for an extended amount of time may suffer from reliability concerns.

### Handling Information

	Minimum	Maximum
Storage Temperature Range (Recommended)	-50 C	+125 C
Moisture Sensitivity Level	MSL 3	



Atlanta Micro products are electrostatic sensitive.  
Follow safe handling practices to avoid damage

### Recommended Operating Conditions

	Minimum	Typical	Maximum
Supply Voltage	+2.7 V	+5.0 V	
Operating Case Temperature	-40 C		+85 C
Operating Junction Temperature	-40 C		+125 C

# AM6017 – Switch

## DC – 26.5 GHz SP4T

### DC Electrical Characteristics

(T = 25 °C unless otherwise specified)

Parameter	Testing Conditions	Minimum	Typical	Maximum
DC Supply Voltage		+2.7 V	+5.0 V	
DC Supply Current	V Supply = +3.3 V		7 mA	
	V Supply = +5.0 V		8 mA	
Power Dissipated	V Supply = +3.3 V		23 mW	
	V Supply = +5.0 V		40 mW	
Logic Level Low		0.0 V		+0.5 V
Logic Level High		+2.0 V		+VDD

### RF Performance

(T = 25 °C unless otherwise specified)

Parameter	Testing Conditions	Minimum	Typical	Maximum
Frequency Range		DC		26.5 GHz
Insertion Loss			2.0 dB	
Return Loss			10 dB	
Input IP3	V Supply = +5.0 V		+41 dBm	

### Timing Characteristics

Parameter	Minimum	Typical	Maximum
Switching Speed (Path Enabled → Disabled)		820 ns	
Switching Speed (Path Disabled → Enabled)		1.15 μs	

### State Table

A	B	C*	State
High	High	Low	RF1
High	Low	Low	RF2
Low	High	Low	RF3
Low	Low	Low	RF4
All Other States			Isolation

\*Note: Bit C can be tied to GND.

# AM6017 – Switch

DC – 26.5 GHz SP4T

## Typical Performance

(VDD = +5.0V unless otherwise specified)

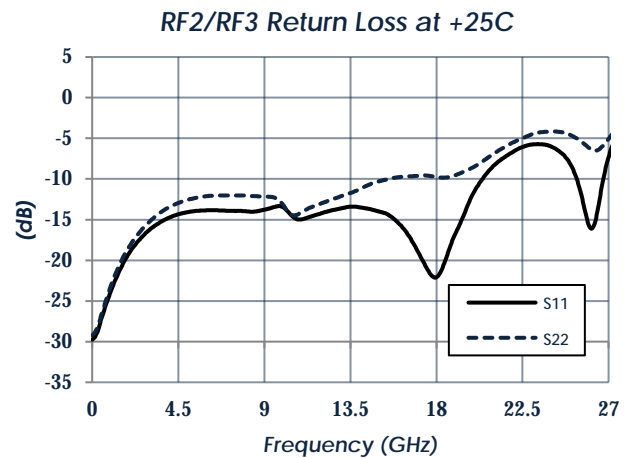
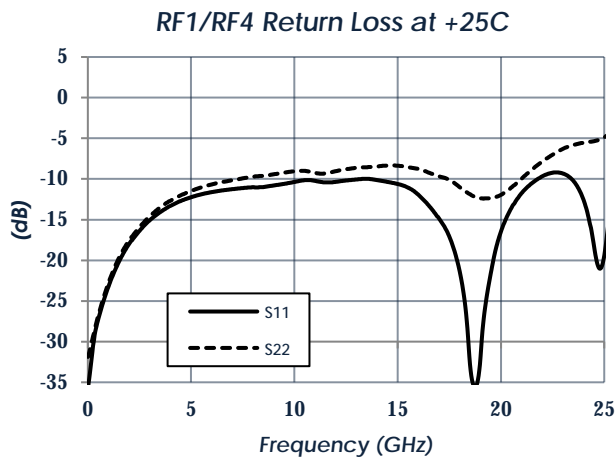
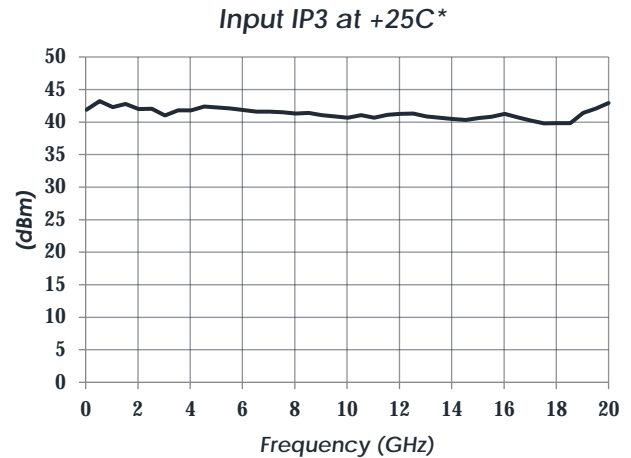
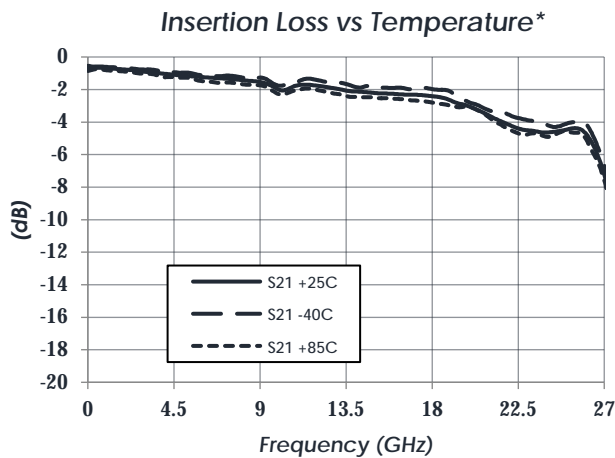
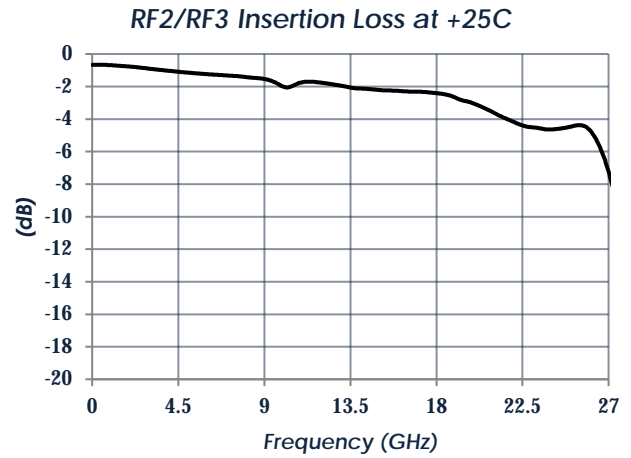
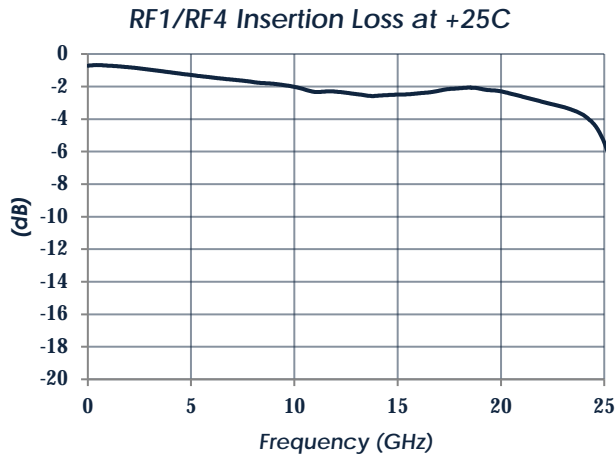

\*Note: RF2/RF3 Path Shown

To obtain price, delivery, or to place an order contact [MMICSales@mrchy.com](mailto:MMICSales@mrchy.com)  
 Atlanta Micro Inc., 3720 Davinci Ct, Suite 125, Peachtree Corners, GA 30092 • Phone: (470) 253-7640 • [www.atlantamicro.com](http://www.atlantamicro.com)

# AM6017 – Switch

DC – 26.5 GHz SP4T

## Typical Performance (continued)

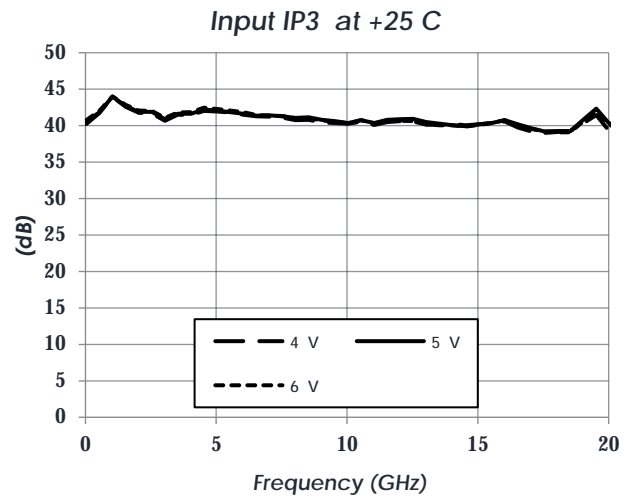
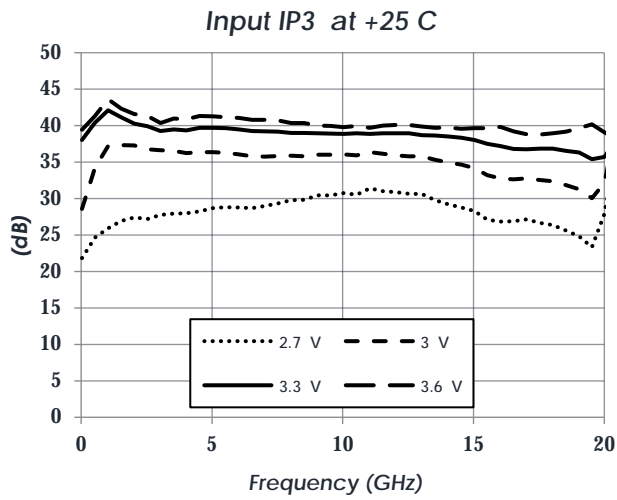

# AM6017 – Switch

DC – 26.5 GHz SP4T

## Typical Application

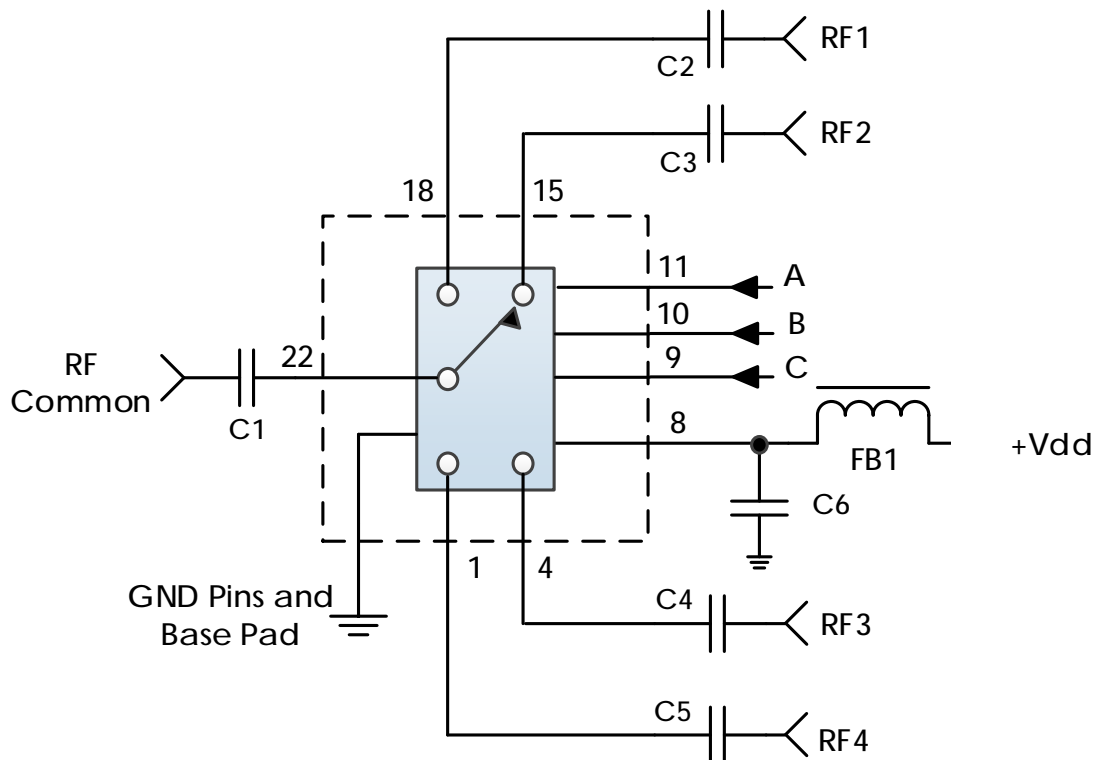

### Recommended Component List (or equivalent):

Part	Value	Part Number	Manufacturer
C1-C5	0.1 $\mu$ F	0402BB104KW160	Passives Plus
C6	0.1 $\mu$ F	C1005X7R1H104K050BB	TDK
FB1	-	MMZ1005A222E	TDK

### Notes:

1. RF blocking capacitors should be high performance, low-loss, broadband capacitors for optimum performance
2. RC filtering on the control lines is recommended to prevent digital noise from coupling to the RF path.
  - a. Select control line RC filter values based on desired logic source decoupling and switching speed.



# AM6017 – Switch

DC – 26.5 GHz SP4T

## Evaluation PC Board

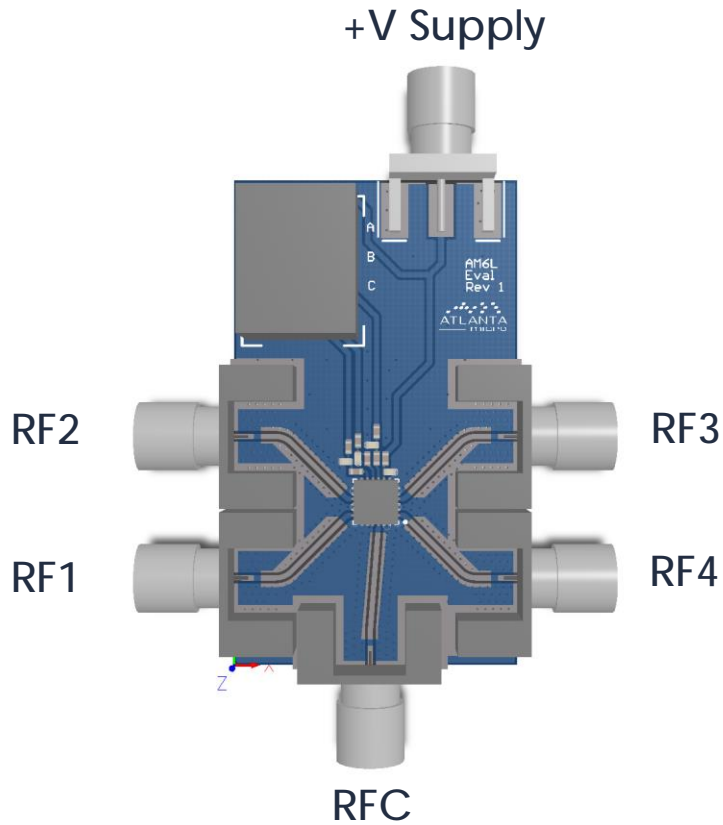

## Related Parts

Part Number	Description
AM6002	DC – 14 GHz SPDT
AM6011	DC – 10 GHz SP8T
AM6012	DC – 18 GHz SPDT
AM6015	DC – 18 GHz SP6T

# AM6017 – Switch

DC – 26.5 GHz SP4T

## Component Compliance Information

**RoHS:** Atlanta Micro, Inc. hereby certifies that all products comply with the EC Directive 2011/65/EC on the Restriction of Hazardous Substances, commonly known as EU-RoHS 6 and 10. All products supplied by Atlanta Micro shall be compliant with the European Directive 2011/65/EC based on the following substance list.

Substance List	Allowable Maximum Concentration
Lead (Pb)	<1000 PPM (0.1% by weight)
Mercury (Hg)	<1000 PPM (0.1% by weight)
Cadmium (Cd)	<75 PPM (0.0075% by weight)
Hexavalent Chromium (CrVI)	<1000 PPM (0.1% by weight)
Polybrominated Biphenyls (PBB)	<1000 PPM (0.1% by weight)
Polybrominated Diphenyl ethers (PBDE)	<1000 PPM (0.1% by weight)
Decabromodiphenyl Deca BDE	<1000 PPM (0.1% by weight)
Bis (2-ethylhexyl) Phthalate (DEHP)	<1000 PPM (0.1% by weight)
Butyl Benzyl Phthalate (BBP)	<1000 PPM (0.1% by weight)
Dibutyl Phthalate (DBP)	<1000 PPM (0.1% by weight)
Diisobutyl Phthalate (DIBP)	<1000 PPM (0.1% by weight)

**REACH:** Atlanta Micro, Inc. neither uses nor intentionally adds any of the substances considered to be a Substance of Very High Concern (SVHC) as defined by the EU Regulation (EC) No. 1907-2006 on Registration, Evaluation, Authorization, and Restriction of Chemicals (REACH).

**Conflict Materials:** Atlanta Micro does not knowingly use materials that are sourced from the Democratic Republic of Congo (DRC) or any other known conflict regions. Atlanta Micro's supply chain is comprised of sources that are both environmentally and socially responsible. We periodically review this requirement with our vendors to ensure continued compliance.

Atlanta Micro takes its responsibility as a global partner seriously and will use due diligence within our supply chain to ensure all standards are met to the best of our knowledge.