

AM6029 – Switch, Reflective

DC to 18 GHz SP4T

Description

AM6029 is a reflective single-pole 4-throw (SP4T) switch covering the DC to 18 GHz frequency range and was designed for use in a wide range of wireless applications. The AM6029 provides low insertion loss, a flat frequency response, high linearity, and fast switching speed making this switch ideal for high frequency low power transmit/receive applications. The AM6029 requires only a single positive supply and two positive control voltages to switch the four paths between a low loss thru path or an isolation state. With an operating temperature range of -40C to +85C, internal 50Ω matching, internal decoder circuitry, and low current draw all packaged in a 3mm QFN, the AM6029 represents a compact total PCB footprint with minimal size, weight, and power (low SWaP).

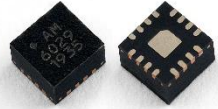

Features

- 1.5 dB Insertion Loss
- +48 dBm Input IP3
- +3.3V to +5.0V Supply
- +3.3V to +5.0V Control
- >35 dB Isolation
- 3mm QFN
- -40C to +85C Operation

Functional Diagram

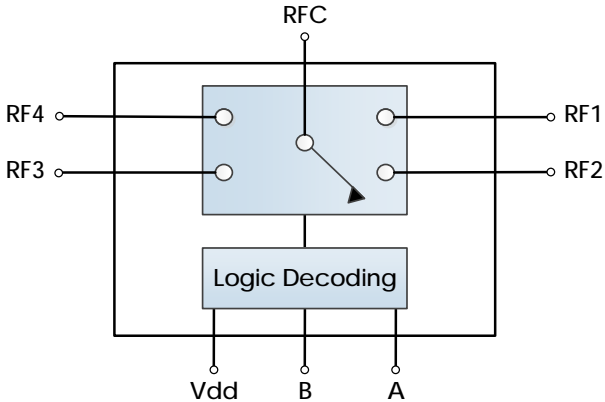

Characteristic Performance

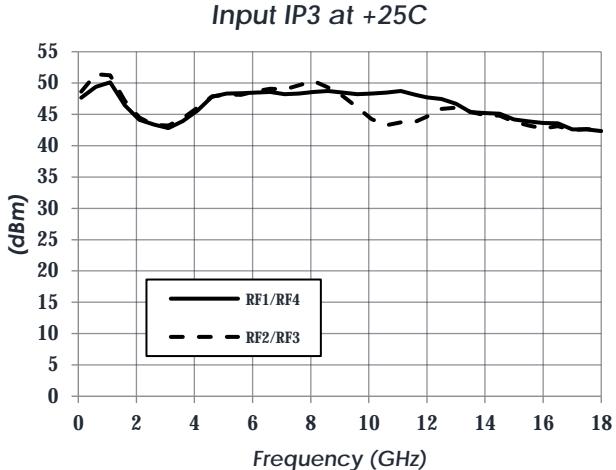
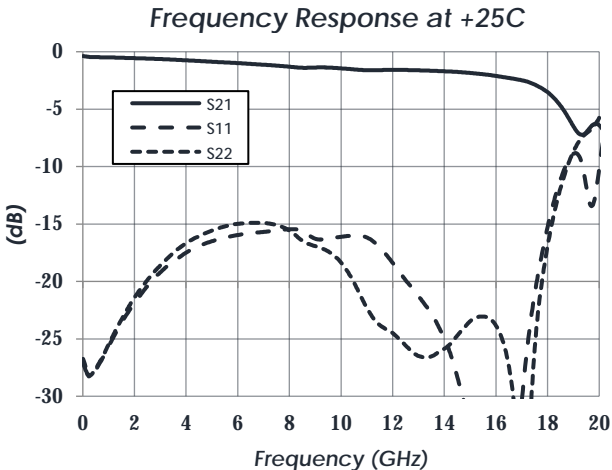

AM6029 – Switch, Reflective

DC to 18 GHz SP4T

Table of Contents

Description	1	DC Electrical Characteristics	5
Features	1	RF Performance	5
Functional Diagram	1	Timing Characteristics	5
Characteristic Performance	1	State Table	5
Revision History	2	Typical Performance	6
Pin Layout and Definitions	3	Typical Application	9
Specifications	4	Evaluation PC Board	10
Absolute Maximum Ratings	4	Related Parts	10
Handling Information	4	Component Compliance Information	11
Recommended Operating Conditions	4		

Revision History

Date	Revision Number	Notes
October 23, 2019	1	Initial Release
October 12, 2020	2	Picture Updated. Packaging information moved to main product page on website.
December 14, 2020	2.1	Fixed Power Dissipated unit and Revision History date

AM6029 – Switch, Reflective

DC to 18 GHz SP4T

Pin Layout and Definitions

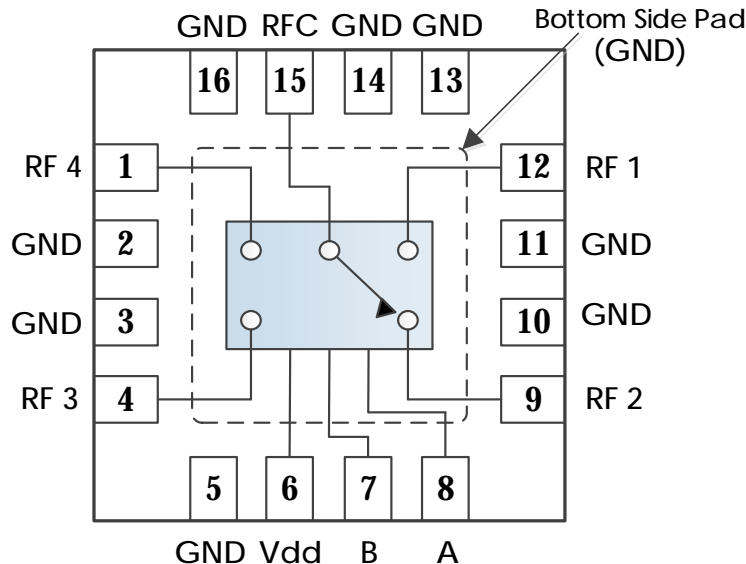

Pin Number	Pin Name	Pin Function
1	RF4	RF4 Output – 50 Ohms – DC Coupled. External DC blocking capacitors required*
2-3	GND	Ground – Common
4	RF3	RF3 Output – 50 Ohms – DC Coupled. External DC blocking capacitors required*
5	GND	Ground – Common
6	VDD	DC Power Input
7	B	Switch Control B
8	A	Switch Control A
9	RF2	RF2 Output – 50 Ohms – DC Coupled. External DC blocking capacitors required*
10-11	GND	Ground – Common
12	RF1	RF1 Output – 50 Ohms – DC Coupled. External DC blocking capacitors required*
13-14	GND	Ground – Common
15	RFC	RFC Input – 50 Ohms – DC Coupled. External DC blocking capacitors required*
16	GND	Ground – Common

*Note: DC blocking caps not required if in series with other Atlanta Micro parts of the same reference voltage

AM6029 – Switch, Reflective

DC to 18 GHz SP4T

Specifications

Absolute Maximum Ratings

	Minimum	Maximum
Supply Voltage	-0.3 V	+6.0 V
RF Input Power		+27 dBm
Operating Junction Temperature	-40 C	+150 C
Storage Temperature Range	-50 C	+150 C

Note: Any device operation beyond the Absolute Maximum Ratings may result in permanent damage to the device. The values listed in this table are extremes and do not imply functional operation of the device at these or any other conditions beyond what is listed under Recommended Operating Conditions. Any part subjected to conditions outside of what is recommended for an extended amount of time may suffer from reliability concerns.

Handling Information

	Minimum	Maximum
Storage Temperature Range (Recommended)	-50 C	+125 C
Moisture Sensitivity Level	MSL 3	



Atlanta Micro products are electrostatic sensitive.
Follow safe handling practices to avoid damage

Recommended Operating Conditions

	Minimum	Typical	Maximum
Supply Voltage	+2.5 V	+5.0 V	
Operating Case Temperature	-40 C		+85 C
Operating Junction Temperature	-40 C		+125 C

AM6029 – Switch, Reflective

DC to 18 GHz SP4T

DC Electrical Characteristics

(T = 25 °C unless otherwise specified)

Parameter	Testing Conditions	Minimum	Typical	Maximum
DC Supply Voltage		+2.5 V	+5.0 V	
DC Supply Current	VDD = +3.3 V		5 mA	
	VDD = +5.0 V		7 mA	
Power Dissipated	VDD = +3.3 V		16.5 mW	
	VDD = 5.0 V		35 mW	
Logic Level Low		0.0 V		+0.5 V
Logic Level High		2.0 V		+VDD

RF Performance

(T = 25 °C unless otherwise specified)

Parameter	Testing Conditions	Minimum	Typical	Maximum
Frequency Range		DC		18 GHz
Insertion Loss	f = 0.01 GHz		0.5 dB	
	f = 9 GHz		1.5 dB	
	f = 18 GHz		3.5 dB	
Return Loss	f = 0.01 GHz		30 dB	
	f = 9 GHz		12 dB	
	f = 18 GHz		12 dB	
Input IP3	VDD = +5.0 V		+48 dBm	

Timing Characteristics

Parameter	Minimum	Typical	Maximum
Switching Speed (Path Enabled to Disabled)		10 ns	
Switching Speed (Path Disabled to Enabled)		11 ns	

State Table

A	B	State
Low	Low	RFC to RF1
Low	High	RFC to RF3
High	Low	RFC to RF2
High	High	RFC to RF4

AM6029 – Switch, Reflective

DC to 18 GHz SP4T

Typical Performance

(VDD = +5.0 V. Data measured via probes outside IC package on 10 mil Rogers RO4350B™)

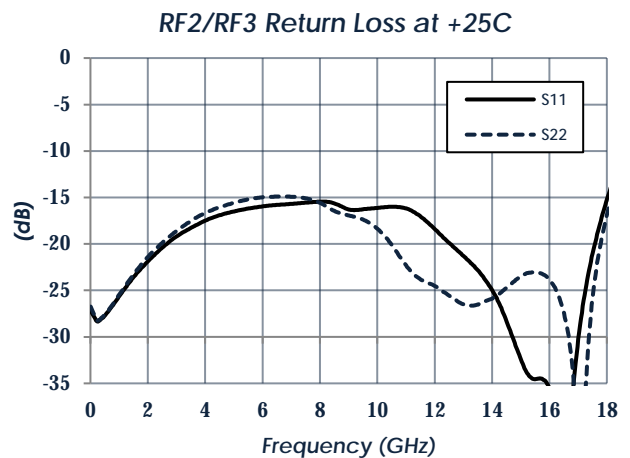
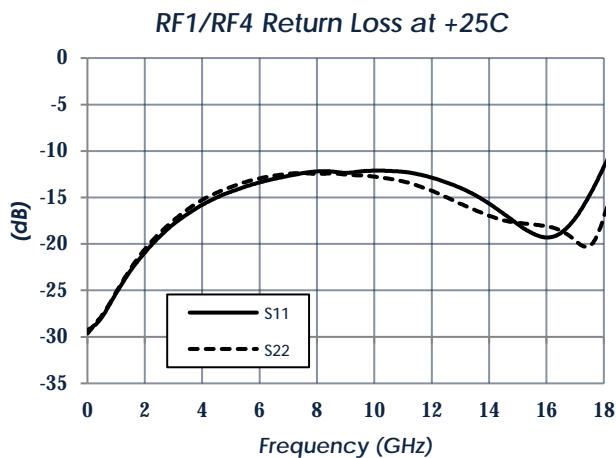
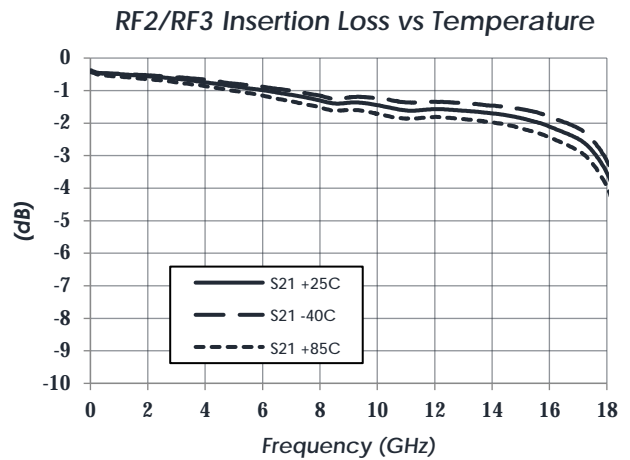
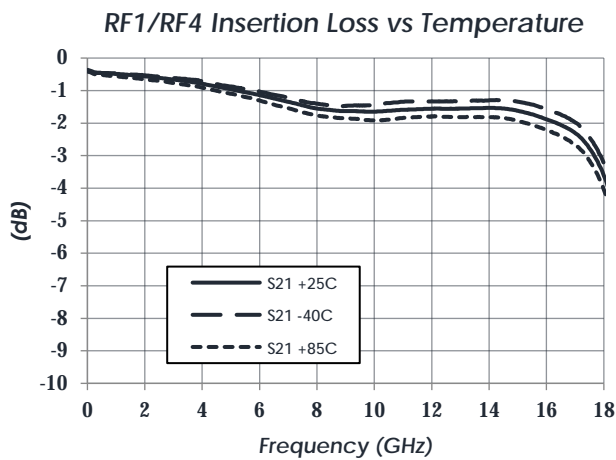
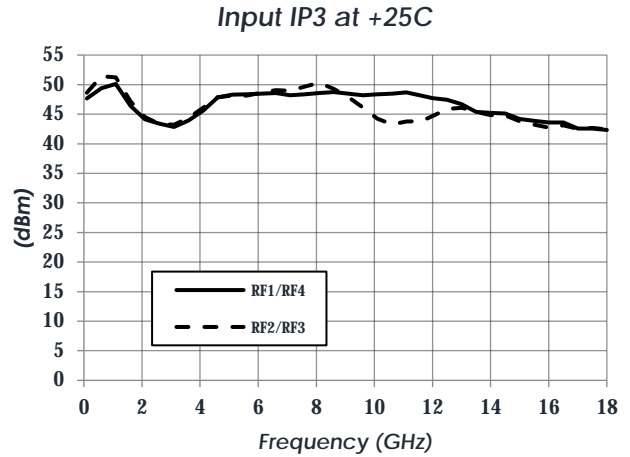
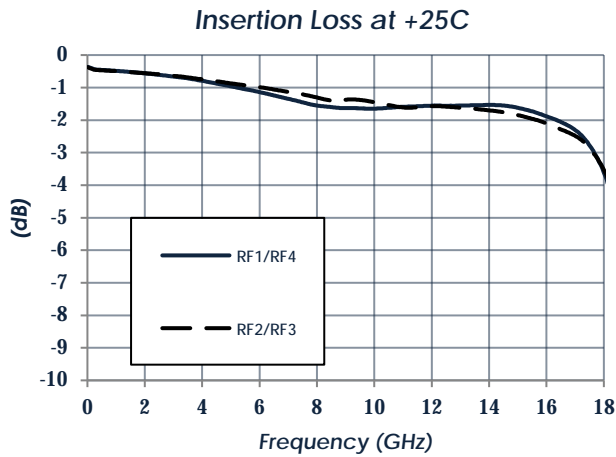

AM6029 – Switch, Reflective

DC to 18 GHz SP4T

Typical Performance (continued)

(VDD = +5.0 V. Data measured on 10 mil Rogers RO4350B™)

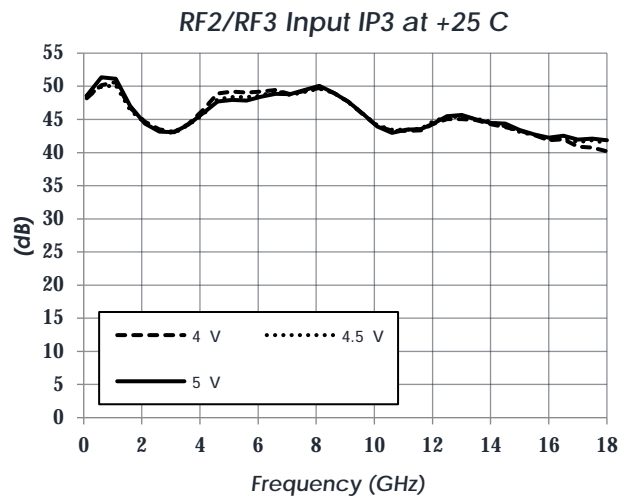
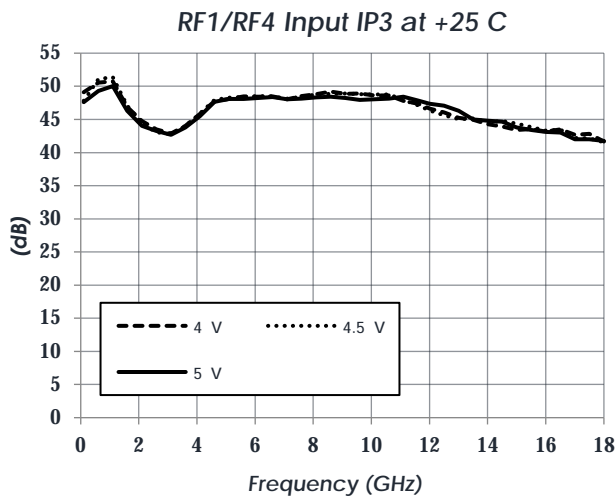
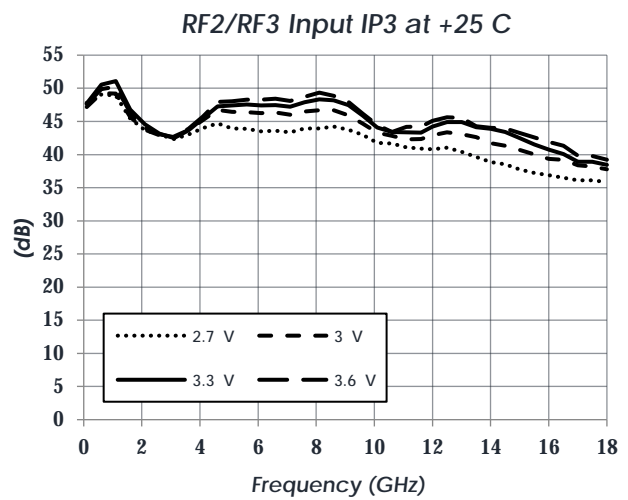
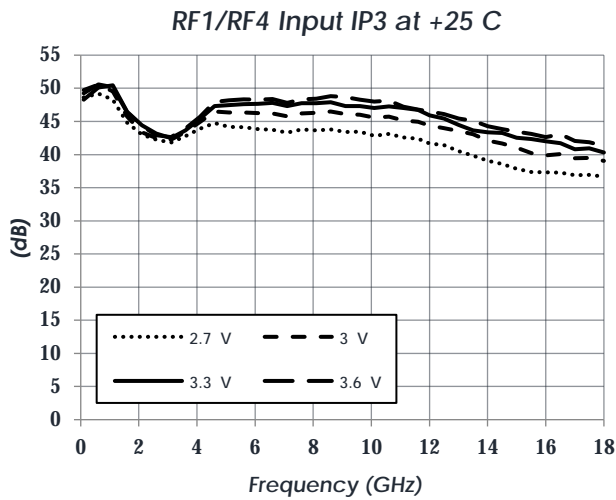
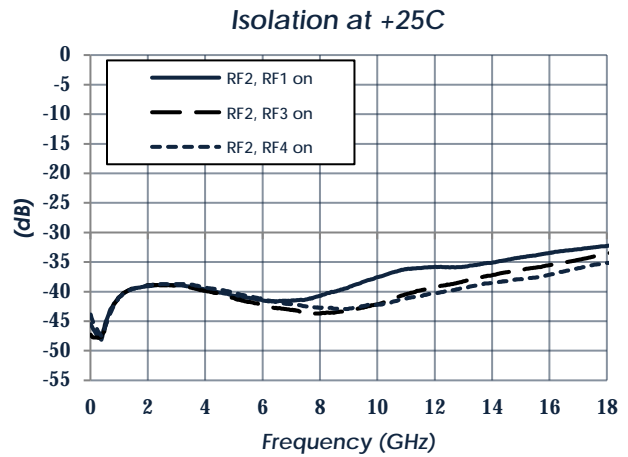
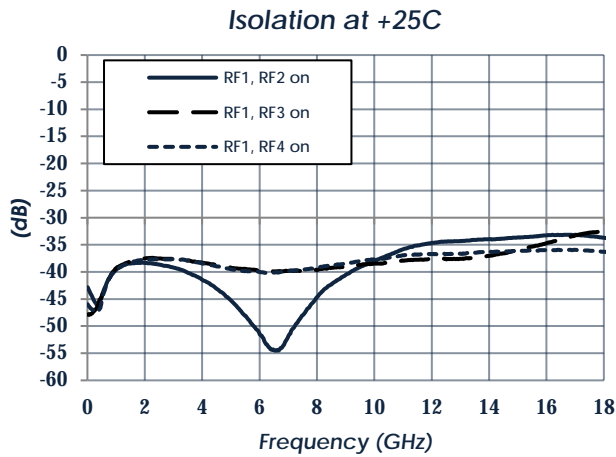

AM6029 – Switch, Reflective

DC to 18 GHz SP4T

Typical Performance (continued)

(VDD = +5.0 V, T = 25C. Data measured on 10 mil Rogers RO4350B™)

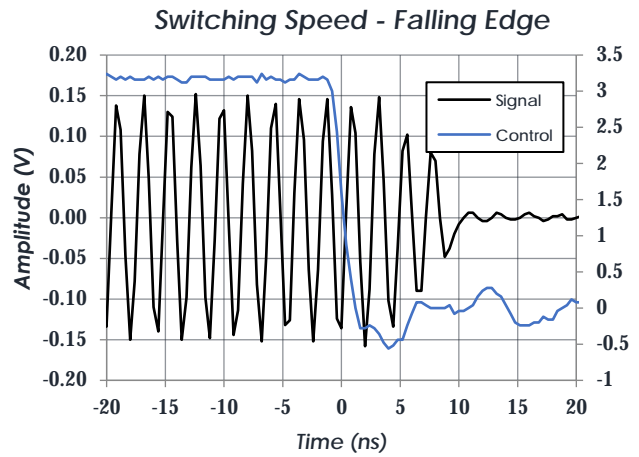
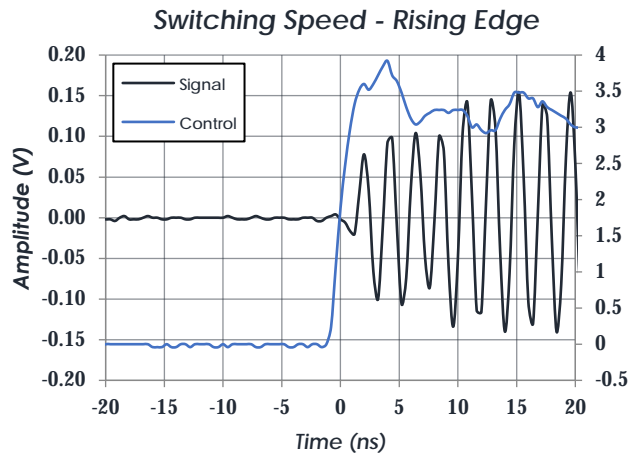

AM6029 – Switch, Reflective

DC to 18 GHz SP4T

Typical Application

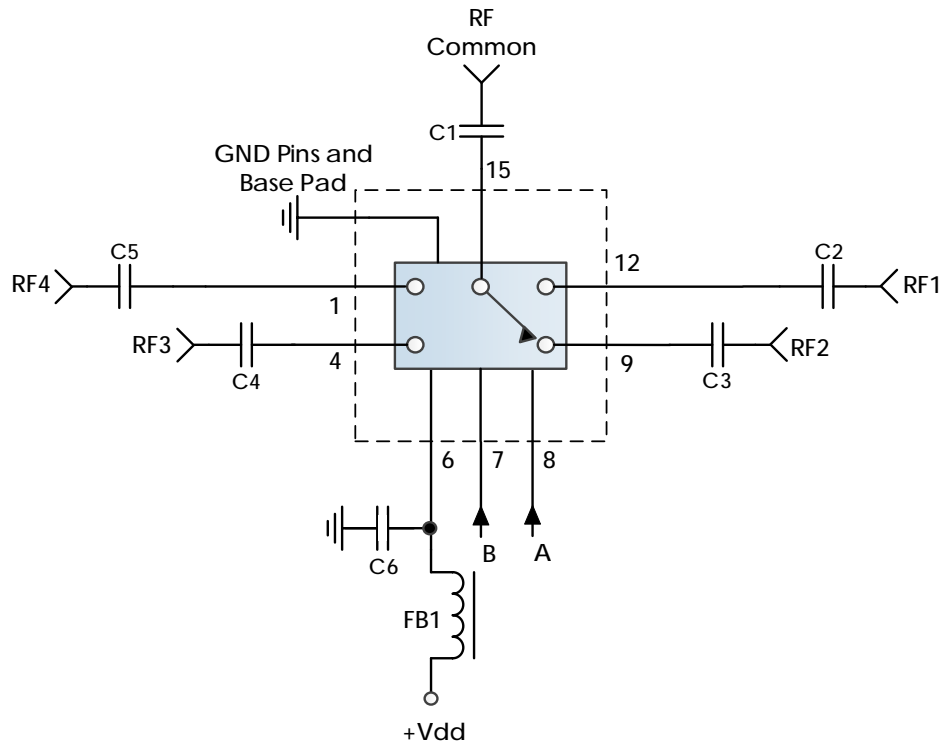

Recommended Component List (or equivalent):

Part	Value	Part Number	Manufacturer
C1-C5	0.1 μ F	0201BB104KW160	Passives Plus
C6	0.1 μ F	C1005X7R1H104K050BB	TDK
FB1	-	MMZ1005A222E	TDK

Notes:

1. DC blocking capacitors should be high performance, low-loss, broadband capacitors for optimal performance.
2. RC Filtering on the control line is recommended to prevent digital noise from coupling to the RF path.
 - a. Select control line RC filter values based on desired logic source decoupling and switching speed.

AM6029 – Switch, Reflective

DC to 18 GHz SP4T

Evaluation PC Board

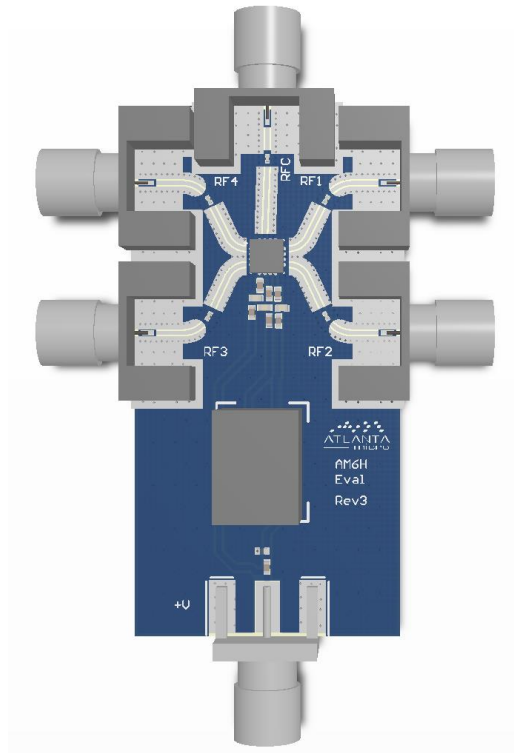

Related Parts

Part Number	Description		
AM6011	DC	to 10 GHz	SP8T, Reflective
AM6012	DC	to 18 GHz	SPDT, Reflective
AM6013	DC	to 20 GHz	SP4T, Reflective
AM6015	DC	to 18 GHz	SP6T, Reflective
AM6016	DC	to 26.5 GHz	SPDT, Reflective
AM6031	DC	to 20 GHz	SPDT, Absorptive

AM6029 – Switch, Reflective

DC to 18 GHz SP4T

Component Compliance Information

RoHS: Atlanta Micro, Inc. hereby certifies that all products comply with the EC Directive 2011/65/EC on the Restriction of Hazardous Substances, commonly known as EU-RoHS 6 and 10. All products supplied by Atlanta Micro shall be compliant with the European Directive 2011/65/EC based on the following substance list.

Substance List	Allowable Maximum Concentration
Lead (Pb)	<1000 PPM (0.1% by weight)
Mercury (Hg)	<1000 PPM (0.1% by weight)
Cadmium (Cd)	<75 PPM (0.0075% by weight)
Hexavalent Chromium (CrVI)	<1000 PPM (0.1% by weight)
Polybrominated Biphenyls (PBB)	<1000 PPM (0.1% by weight)
Polybrominated Diphenyl ethers (PBDE)	<1000 PPM (0.1% by weight)
Decabromodiphenyl Deca BDE	<1000 PPM (0.1% by weight)
Bis (2-ethylhexyl) Phthalate (DEHP)	<1000 PPM (0.1% by weight)
Butyl Benzyl Phthalate (BBP)	<1000 PPM (0.1% by weight)
Dibutyl Phthalate (DBP)	<1000 PPM (0.1% by weight)
Diisobutyl Phthalate (DIBP)	<1000 PPM (0.1% by weight)

REACH: Atlanta Micro, Inc. neither uses nor intentionally adds any of the substances considered to be a Substance of Very High Concern (SVHC) as defined by the EU Regulation (EC) No. 1907-2006 on Registration, Evaluation, Authorization, and Restriction of Chemicals (REACH).

Conflict Materials: Atlanta Micro does not knowingly use materials that are sourced from the Democratic Republic of Congo (DRC) or any other known conflict regions. Atlanta Micro’s supply chain is comprised of sources that are both environmentally and socially responsible. We periodically review this requirement with our vendors to ensure continued compliance.

Atlanta Micro takes its responsibility as a global partner seriously and will use due diligence within our supply chain to ensure all standards are met to the best of our knowledge.