

# AM3089 – Filter Bank

## Analog Tunable 2.0 to 18.0 GHz Bandpass

### Description

AM3089 is an analog voltage-tunable bandpass filter bank covering the 2.0 to 18.0 GHz frequency range. Six bandpass filters with SP6T switches on the input and output are contained in the multi-chip module (MCM). Separate low-pass and high-pass tuning voltages provide independent control of both center frequency and bandwidth. AM3089 provides an excellent filtering solution for receiver or transceiver requiring flexible center frequency and bandwidth, high dynamic range, and small size, weight, and power consumption (low SWAP).

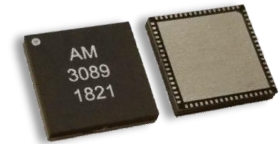

### Features

- Analog Tuning
- Independent LP and HP control
- 8 dB Typical Insertion Loss
- +25 dBm Typical P1dB
- +37 dBm Typical IIP3
- +3.3V to +5V Supply
- +3V to +5V Control
- +0.5V to +10V Tuning Voltage Range
- 10mm QFN Package
- Rotationally Symmetric
- -40C to +85C Operation

### Functional Diagram

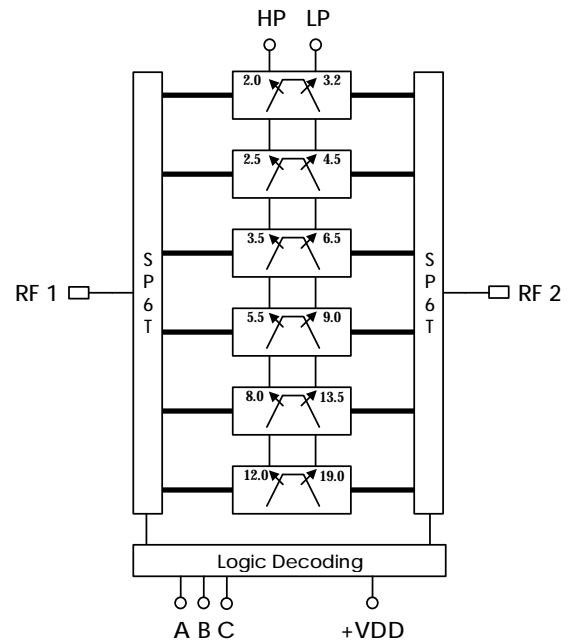

### Characteristic Performance

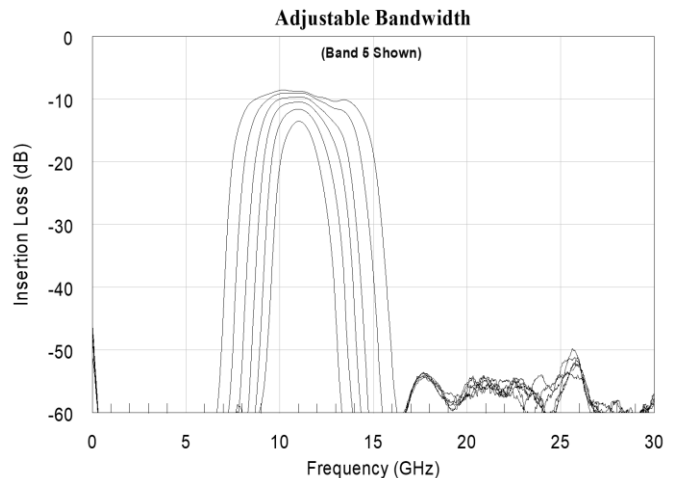
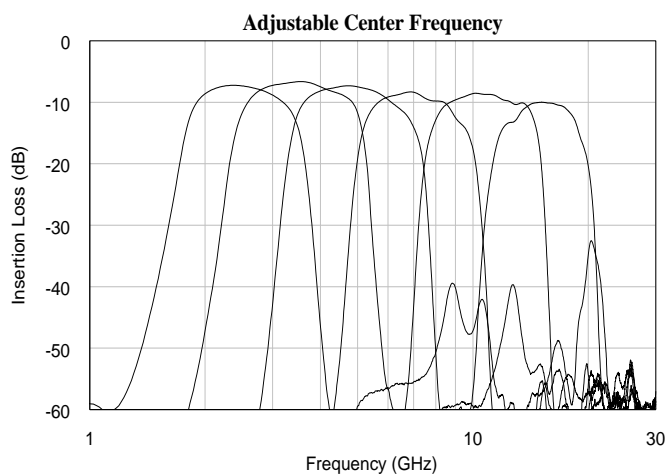

### Table of Contents

Description .....	1	RF Performance .....	5
Features .....	1	Timing Characteristics .....	5
Functional Diagram .....	1	State Table .....	5
Characteristic Performance .....	1	Typical Performance .....	6
Revision History .....	2	<b>Typical Application</b> .....	<b>13</b>
Pin Layout and Definitions .....	3	<b>Alternate Application</b> .....	<b>14</b>
Specifications .....	4	<b>Evaluation PC Board</b> .....	<b>15</b>
Absolute Maximum Ratings .....	4	<b>Related Parts</b> .....	<b>15</b>
Handling Information .....	4	<b>AM3089 / AM3099 Compatibility</b>	
Recommended Operating Conditions .....	4	<b>Application Note</b> .....	<b>16</b>
Thermal Information .....	4	Recommended Application Circuit .....	16
DC Electrical Characteristics .....	5	Recommended Pinout Modification .....	17
		<b>Component Compliance Information</b> .....	<b>18</b>

### Revision History

Date	Revision	Notes
March 14, 2018	0	Preliminary Release
June 4, 2018	1	Initial Release
June 20, 2018	2	Updated Various Pictures. Tune Voltage Settling Time Added
July 11, 2018	2A	State Table Corrected
August 2, 2018	3	Specifications Updated. Typical Application Component List Fixed. Added Related Parts.
September 28, 2018	4	Tune Voltage Settling Time Corrected. IIP3 vs Tune Voltage Plot Added.
June 25, 2019	5	Evaluation PC Board Image Corrected.
November 4, 2019	6	AM3089/AM3099 Application Note Added. Settling Time and Package Details Updated.
January 16, 2020	7	Update Performance Plots.
October 6, 2020	8	Control logic voltage range should match Vdd. Packaging information moved to main product page on website.

# AM3089 – Filter Bank



## Analog Tunable 2.0 to 18.0 GHz Bandpass

### Pin Layout and Definitions

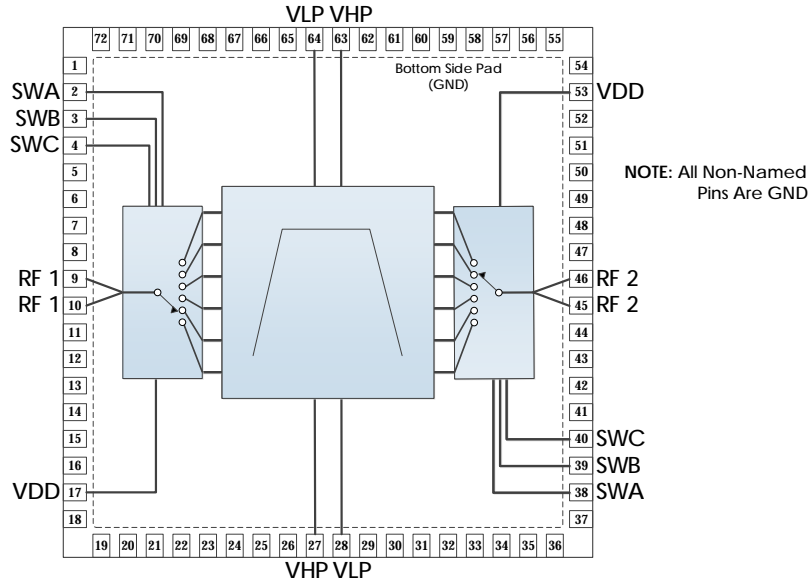

Pin Number	Pin Name	Pin Function
1	GND	Ground
2	SWA	Switch Control A
3	SWB	Switch Control B
4	SWC	Switch Control C
5-8	GND	Ground
9,10	RF1	RF1 – 50 Ohms – DC Coupled, External Blocking Cap Needed*
11-16	GND	Ground
17	VDD	DC Power Input
18-26	GND	Ground
27	VHP	High Pass DC Control Voltage
28	VLP	Low Pass DC Control Voltage
29-37	GND	Ground
38	SWA	Switch Control A
39	SWB	Switch Control B
40	SWC	Switch Control C
41-44	GND	Ground
45,46	RF2	RF2 – 50 Ohms – DC Coupled, External Blocking Cap Needed*
47-52	GND	Ground
53	VDD	DC Power Input
54-62	GND	Ground
63	VHP	High Pass DC Control Voltage
64	VLP	Low Pass DC Control Voltage
65-72	GND	Ground
Case GND	GND	Ground

\*Note: DC blocking caps not required if in series with other Atlanta Micro parts of the same reference voltage.

# AM3089 – Filter Bank



Analog Tunable 2.0 to 18.0 GHz Bandpass

## Specifications

### Absolute Maximum Ratings

	Minimum	Maximum
Supply Voltage	-0.3 V	+6.0 V
DC Control Voltage	0.0 V	+12.0 V
RF Input Power		+27 dBm
Operating Junction Temperature	-40 C	+150 C
Storage Temperature Range	-50 C	+150 C

**Note:** Any device operation beyond the Absolute Maximum Ratings may result in permanent damage to the device. The values listed in this table are extremes and do not imply functional operation of the device at these or any other conditions beyond what is listed under Recommended Operating Conditions. Any part subjected to conditions outside of what is recommended for an extended amount of time may suffer from reliability concerns.

### Handling Information

	Minimum	Maximum
Storage Temperature Range (Recommended)	-50 C	+125 C
Moisture Sensitivity Level	MSL 3	



Atlanta Micro products are electrostatic sensitive.  
Follow safe handling practices to avoid damage

### Recommended Operating Conditions

	Minimum	Typical	Maximum
Supply Voltage	+2.7 V	+5.0 V	
Operating Case Temperature	-40 C		+85 C
Operating Junction Temperature	-40 C		+125 C

### Thermal Information

	Thermal Resistance (°C / W)
Junction to Case Thermal Resistance ( $\theta_{JC}$ )	144

# AM3089 – Filter Bank

## Analog Tunable 2.0 to 18.0 GHz Bandpass

### DC Electrical Characteristics

(T = 25 °C unless otherwise specified)

Parameter	Testing Conditions	Minimum	Typical	Maximum
DC Supply Voltage		+2.7 V	+5.0 V	
DC Supply Current	V Supply = +3.3 V		16 mA	
	V Supply = +5.0 V		20 mA	
Power Dissipated	V Supply = +3.3 V		53 mW	
	V Supply = +5.0 V		100 mW	
Logic Level Low		0.0 V		+0.5 V
Logic Level High (1)		Vdd - 0.5V		Vdd
DC Control Voltage		+0.5 V		+10.0 V
DC Control Current			< 1 mA	

(1) Control logic should use same voltage level as Vsupply

### RF Performance

(T = 25 °C, VDD = +5.0 V unless otherwise specified)

Parameter	Testing Conditions	Minimum	Typical	Maximum
Frequency Range		2.0 GHz		18.0 GHz
Insertion Loss	f = 2.0 GHz		7.3 dB	
	f = 7.0 GHz		7.2 dB	
	f = 13.0 GHz		7.8 dB	
	f = 18.0 GHz		10.5 dB	
Return Loss	f = 2.0 GHz		20.4 dB	
	f = 7.0 GHz		18.0 dB	
	f = 13.0 GHz		23.5 dB	
	f = 18.0 GHz		16.9 dB	
Input IP3			+39 dBm	
Input P1dB			+25 dBm	

### Timing Characteristics

Parameter	Minimum	Typical	Maximum
Band Switching Speed		1 $\mu$ s	
Tune Voltage Settling Time			2 $\mu$ s/V

### State Table

A	B	C	State
Low	Low	High	Band 1 – 2.0 - 3.2 GHz
Low	High	Low	Band 6 – 12.0 - 18.0 GHz
Low	High	High	Band 4 – 5.5 - 9.0 GHz
High	Low	Low	Band 5 – 8.0 - 13.5 GHz
High	Low	High	Band 3 – 3.5 - 6.5 GHz
High	High	Low	Band 2 – 2.5 - 4.5 GHz
All Other States			Do Not Use

# AM3089 – Filter Bank

## Analog Tunable 2.0 to 18.0 GHz Bandpass

### Typical Performance

(Note: Only some states shown for simplicity)

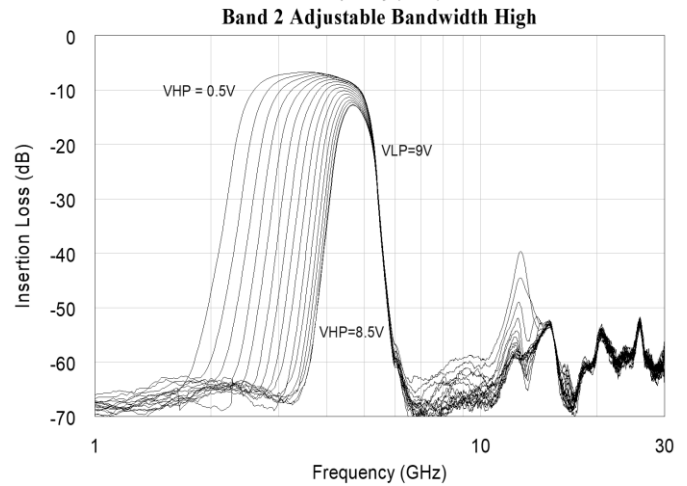
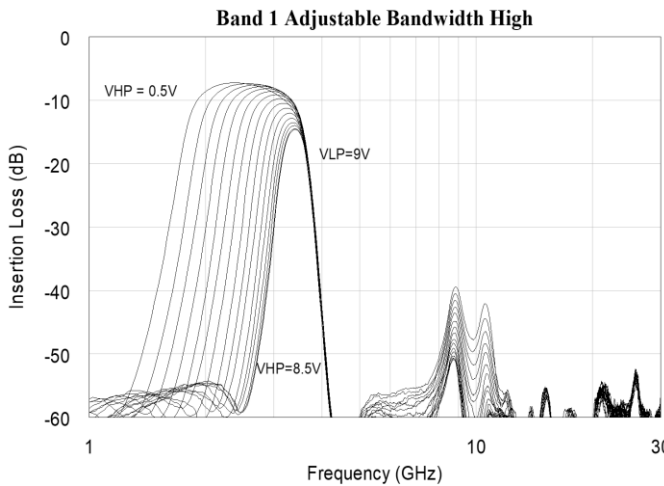
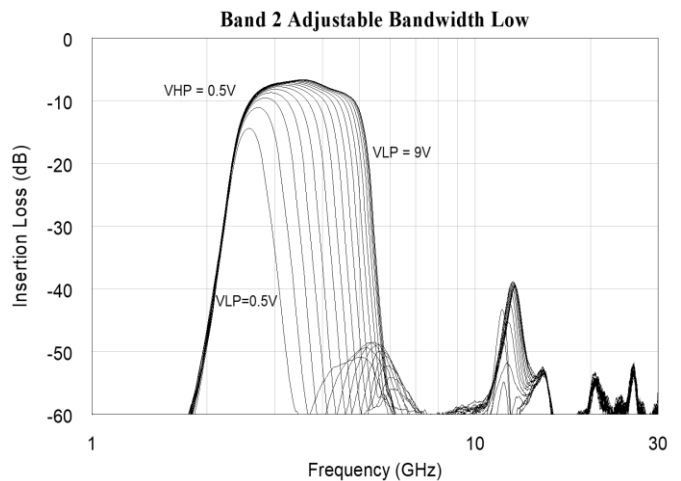
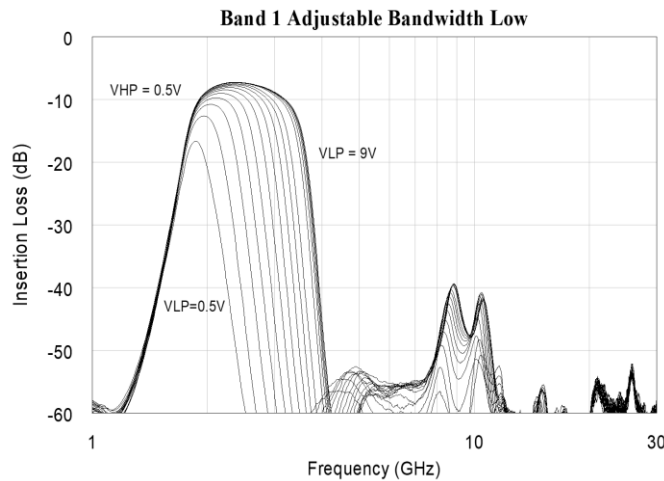
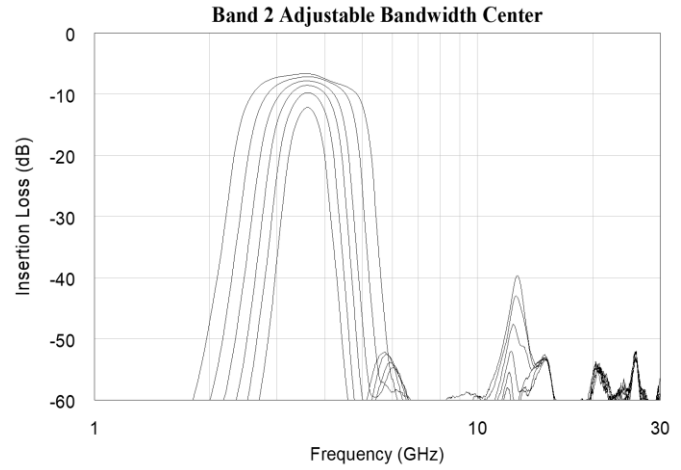
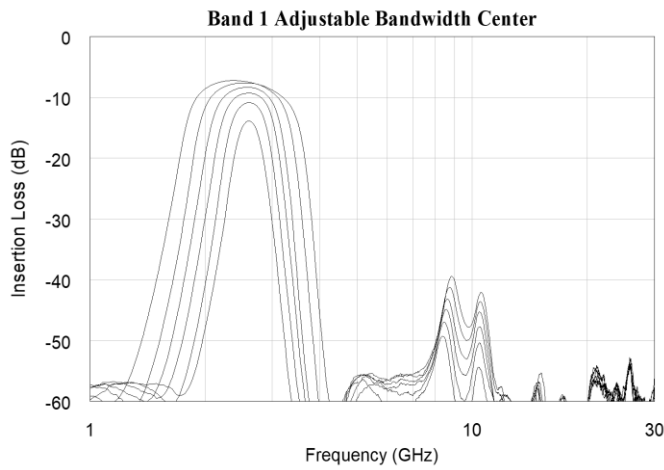

# AM3089 – Filter Bank

## Analog Tunable 2.0 to 18.0 GHz Bandpass

### Typical Performance (continued)

(Note: Only some states shown for simplicity)

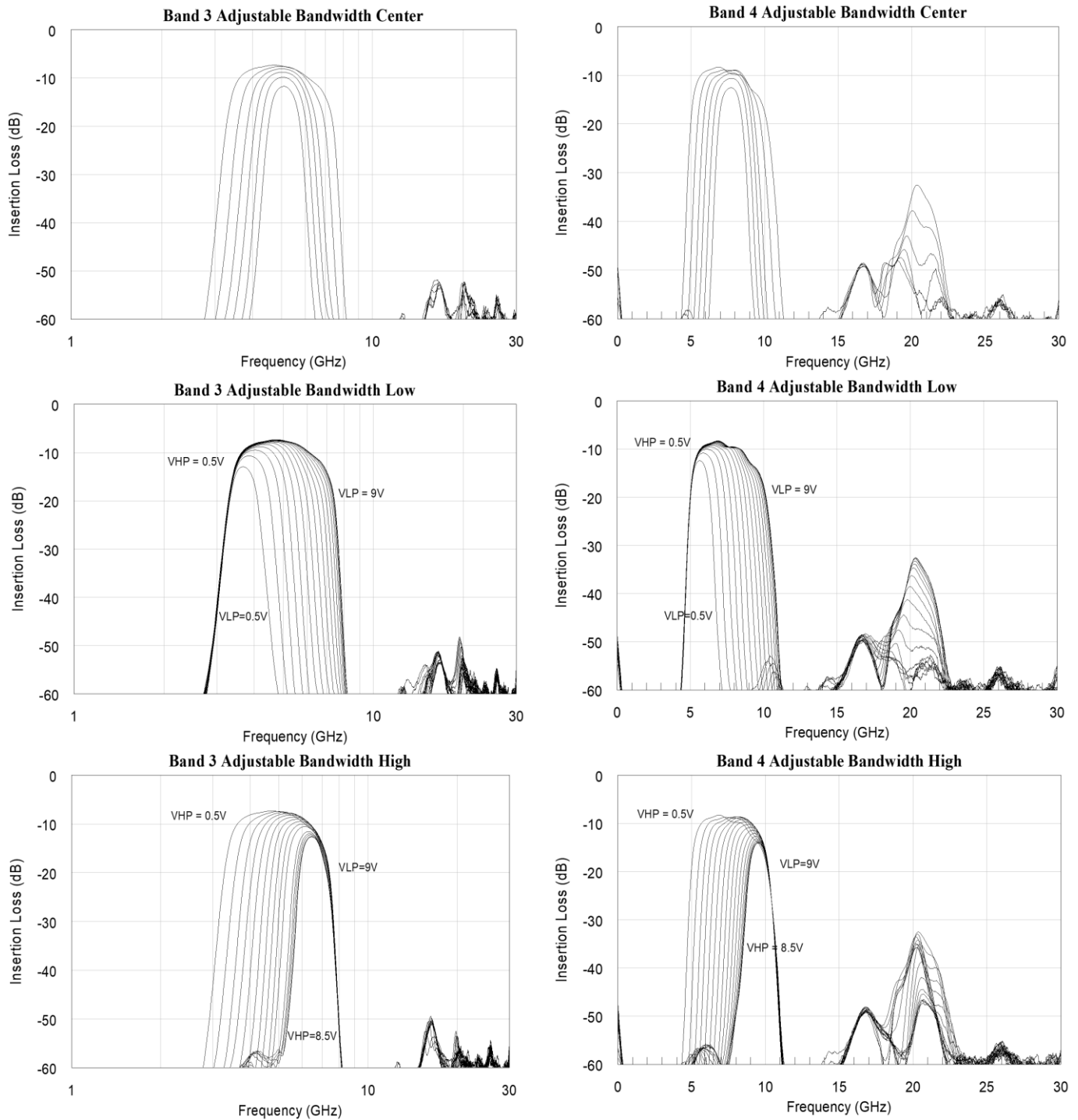

To obtain price, delivery, or to place an order contact [MMICSales@mrcty.com](mailto:MMICSales@mrcty.com)  
 Atlanta Micro Inc., 3720 Davinci Ct, Suite 125, Norcross, GA 30092 • Phone: (470) 253-7640 • [www.atlantamicro.com](http://www.atlantamicro.com)

# AM3089 – Filter Bank



## Analog Tunable 2.0 to 18.0 GHz Bandpass

### Typical Performance (continued)

(Note: Only some states shown for simplicity)

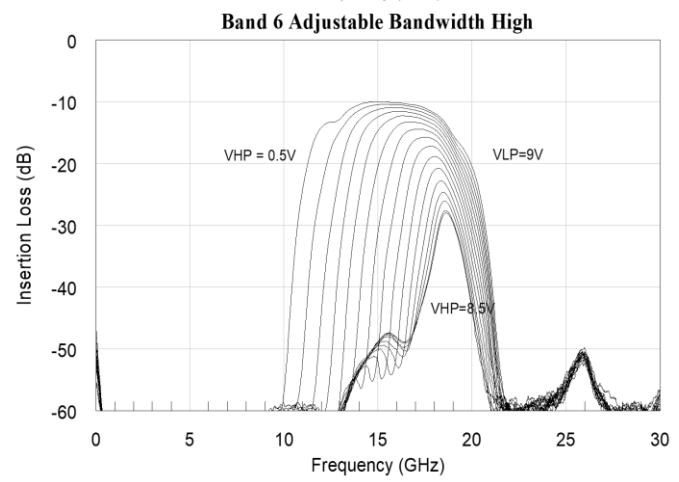
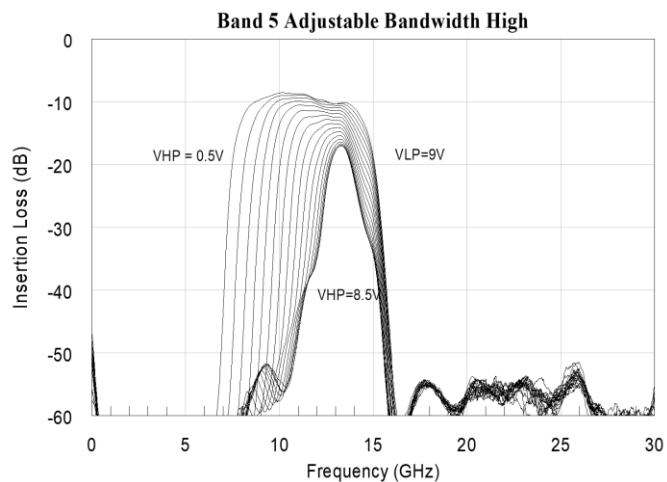
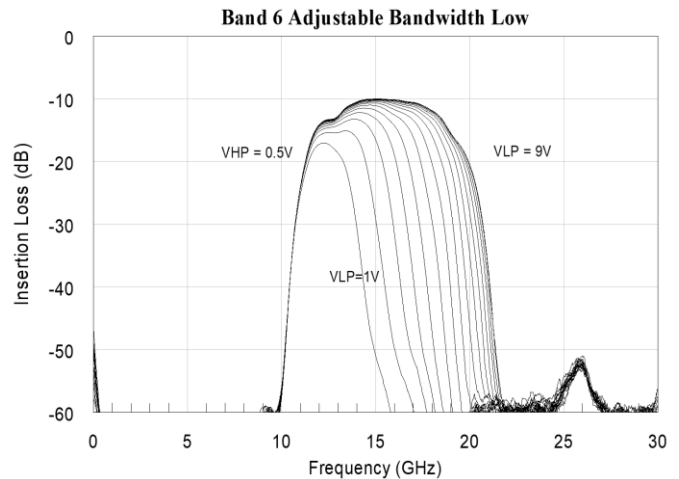
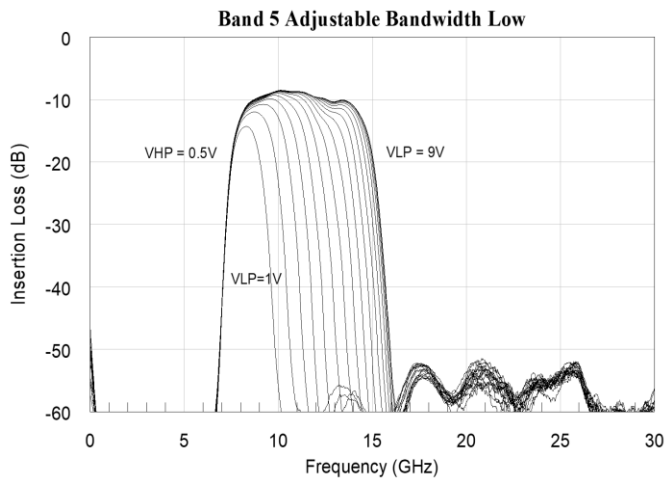
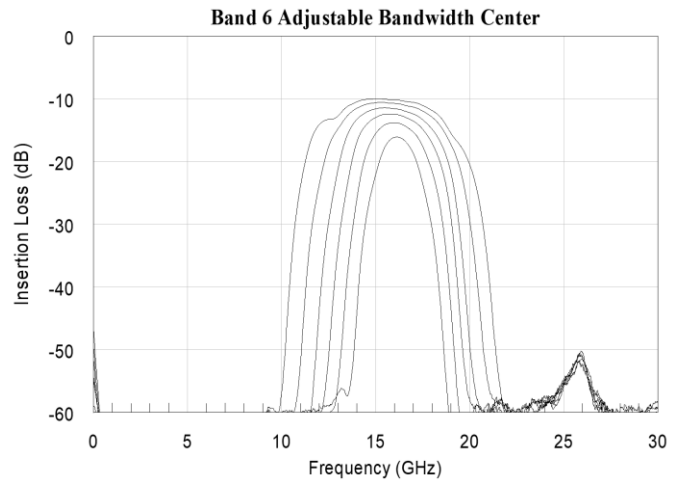
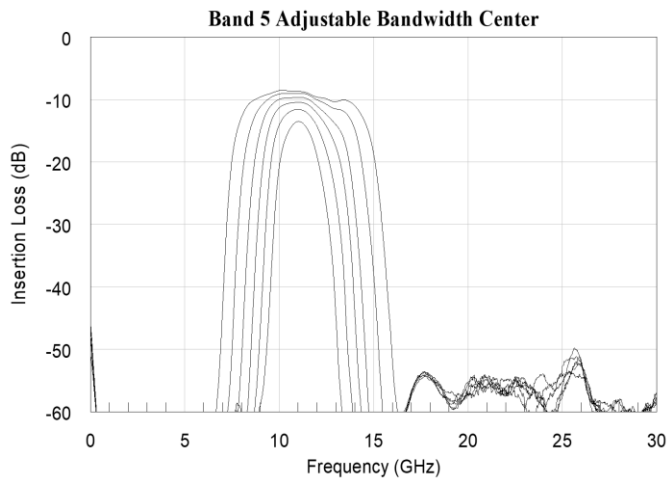

To obtain price, delivery, or to place an order contact [MMICSales@mrcty.com](mailto:MMICSales@mrcty.com)  
Atlanta Micro Inc., 3720 Davinci Ct, Suite 125, Norcross, GA 30092 • Phone: (470) 253-7640 • [www.atlantamicro.com](http://www.atlantamicro.com)



# AM3089 – Filter Bank



## Analog Tunable 2.0 to 18.0 GHz Bandpass

### Typical Performance (continued)

(Note: Only some states shown for simplicity)

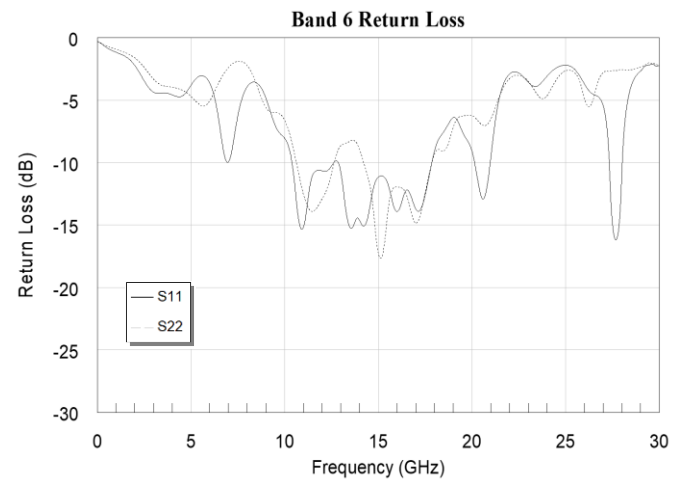
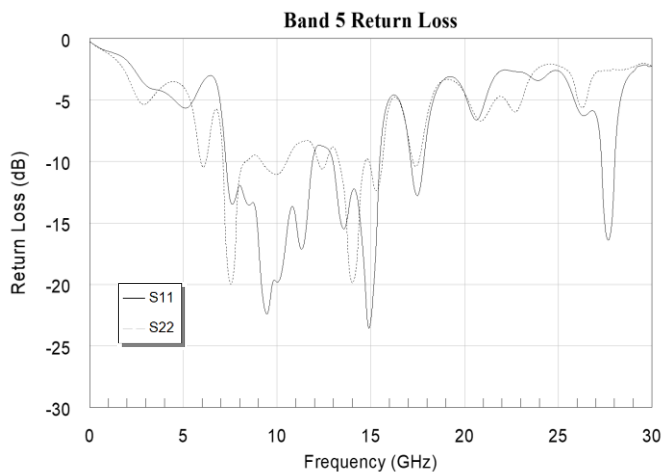
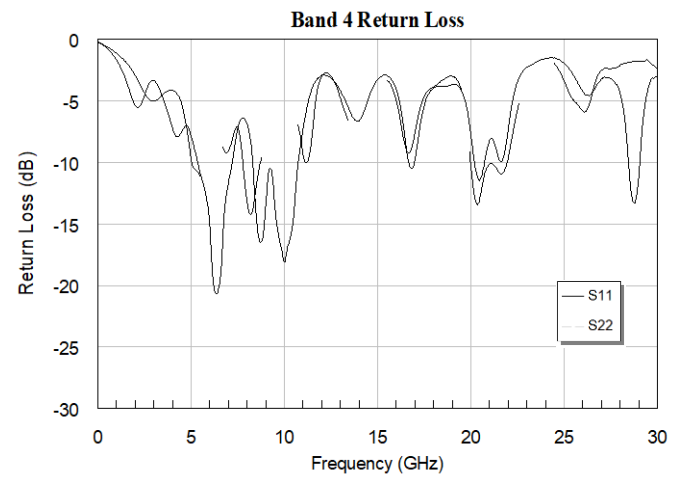
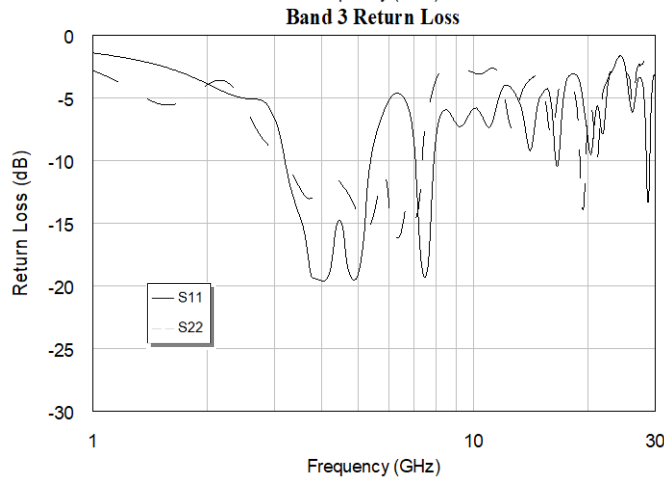
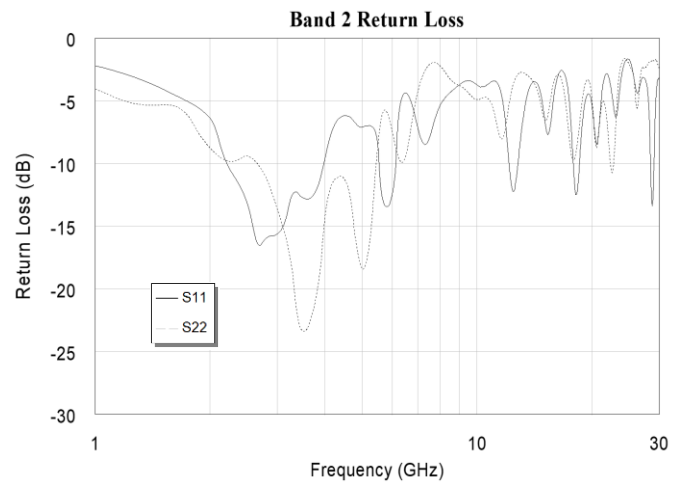
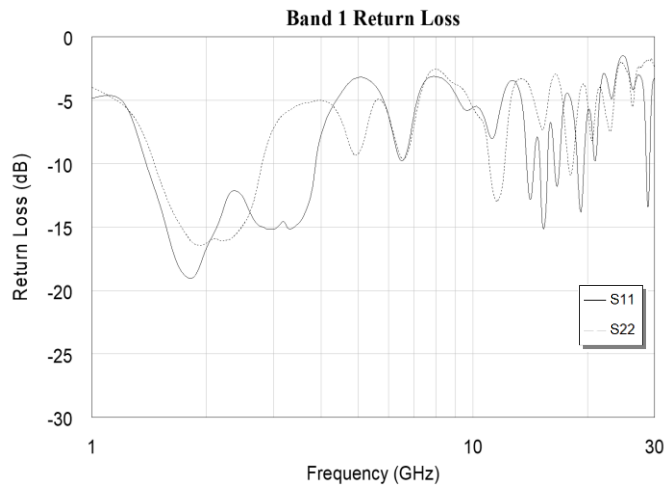

To obtain price, delivery, or to place an order contact [MMICSales@mrcty.com](mailto:MMICSales@mrcty.com)  
Atlanta Micro Inc., 3720 Davinci Ct, Suite 125, Norcross, GA 30092 • Phone: (470) 253-7640 • [www.atlantamicro.com](http://www.atlantamicro.com)

# AM3089 – Filter Bank



## Analog Tunable 2.0 to 18.0 GHz Bandpass

### Typical Performance (continued)

(Note: Only some states shown for simplicity)

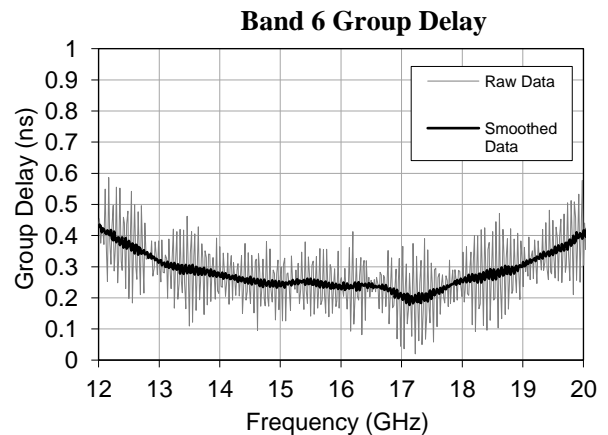
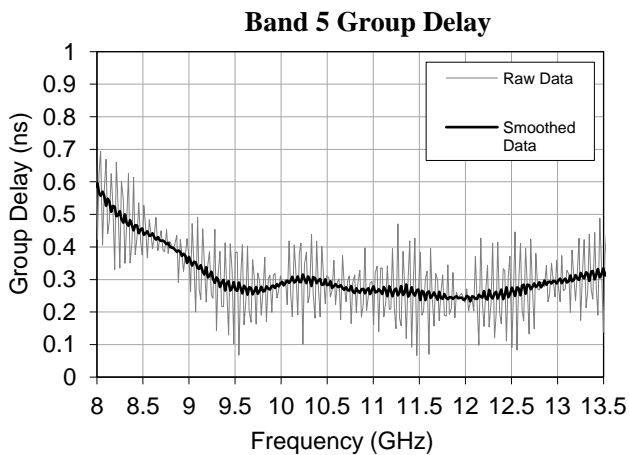
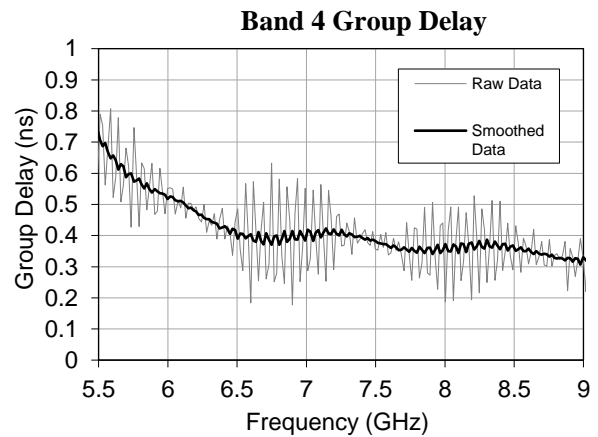
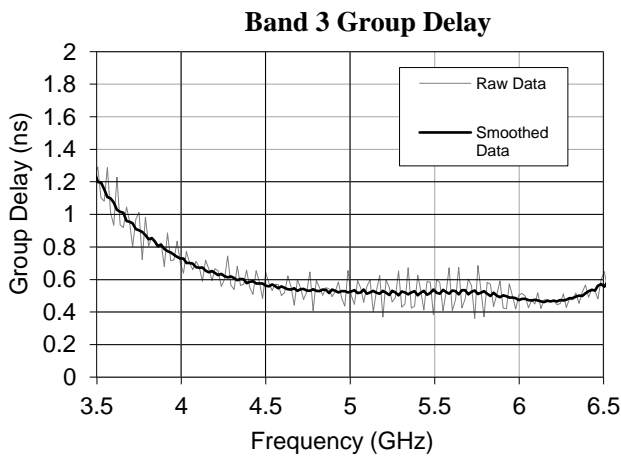
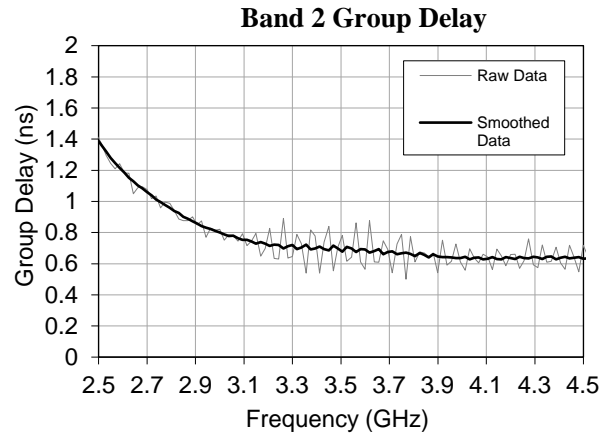
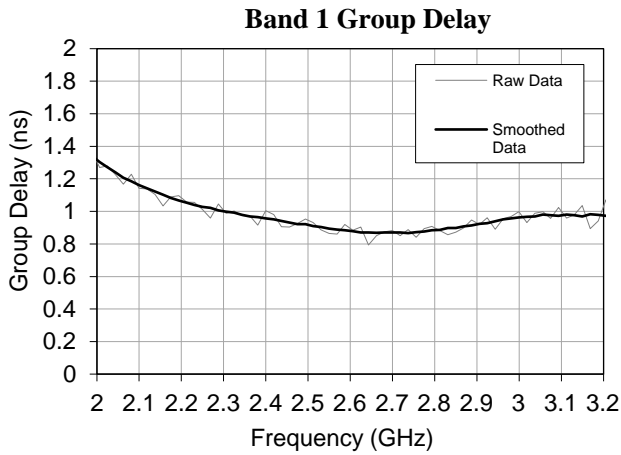

To obtain price, delivery, or to place an order contact [MMICSales@mrcty.com](mailto:MMICSales@mrcty.com)  
Atlanta Micro Inc., 3720 Davinci Ct, Suite 125, Norcross, GA 30092 • Phone: (470) 253-7640 • [www.atlantamicro.com](http://www.atlantamicro.com)

# AM3089 – Filter Bank



## Analog Tunable 2.0 to 18.0 GHz Bandpass

### Typical Performance (continued)

(Note: Only some states shown for simplicity, data only shown for passband)

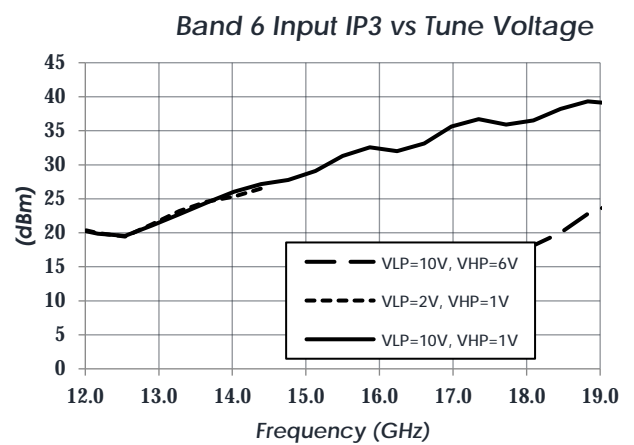
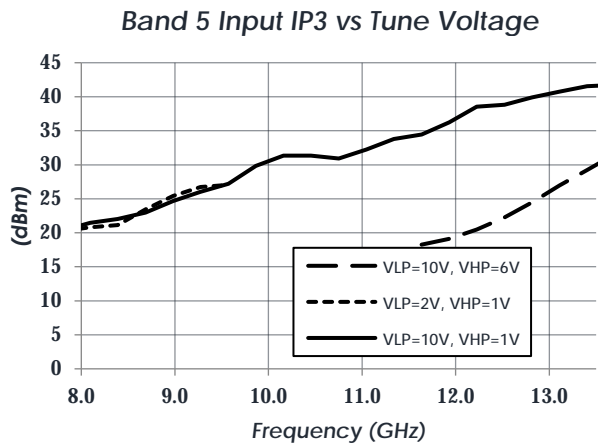
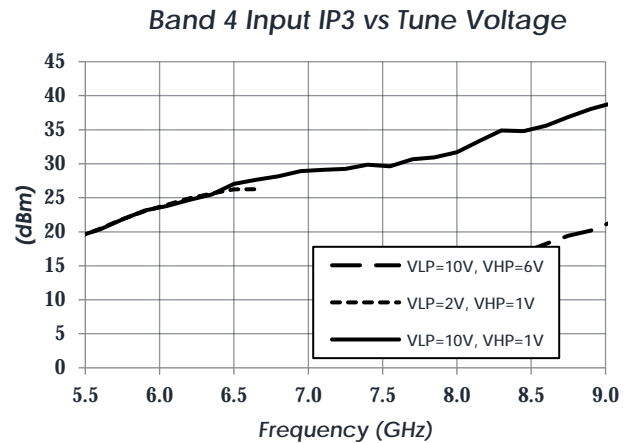
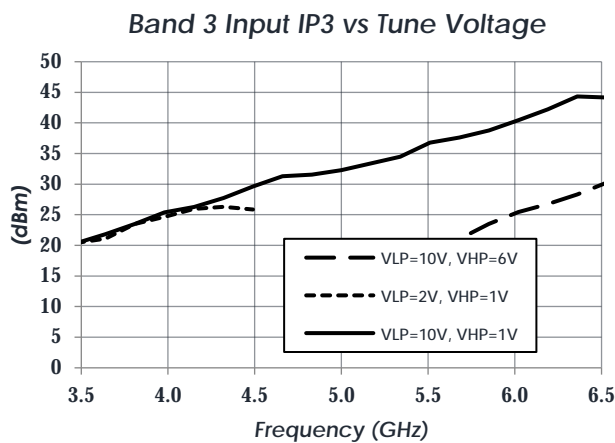
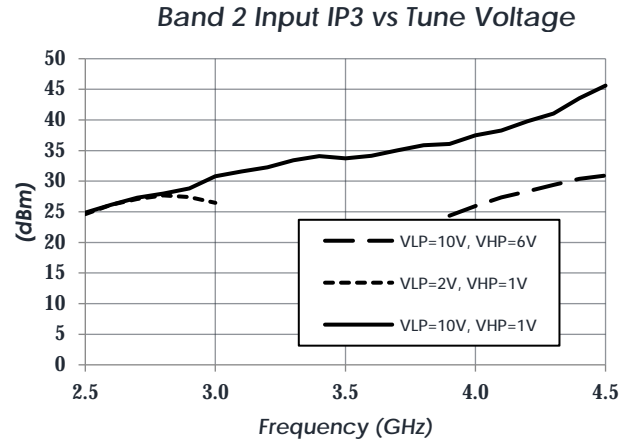
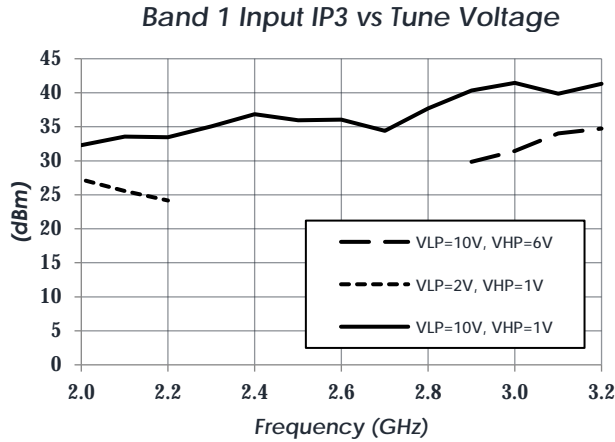

# AM3089 – Filter Bank



## Analog Tunable 2.0 to 18.0 GHz Bandpass

### Typical Performance (continued)

(Note: Only some states shown for simplicity, data only shown for passband)

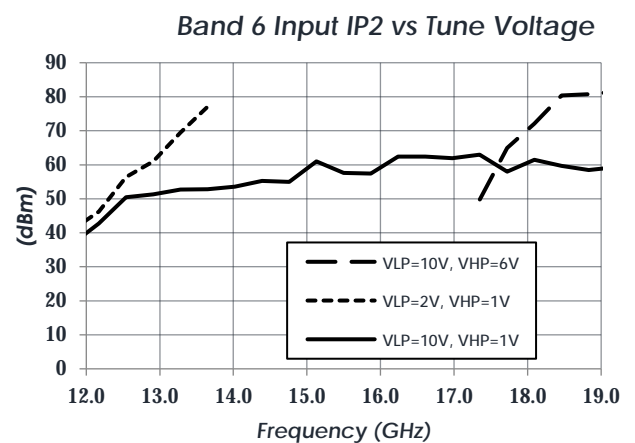
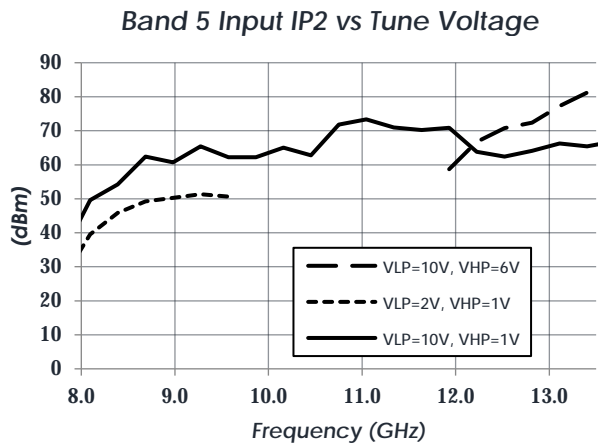
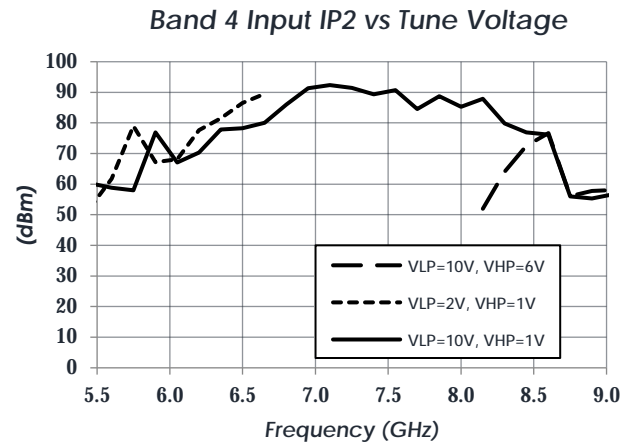
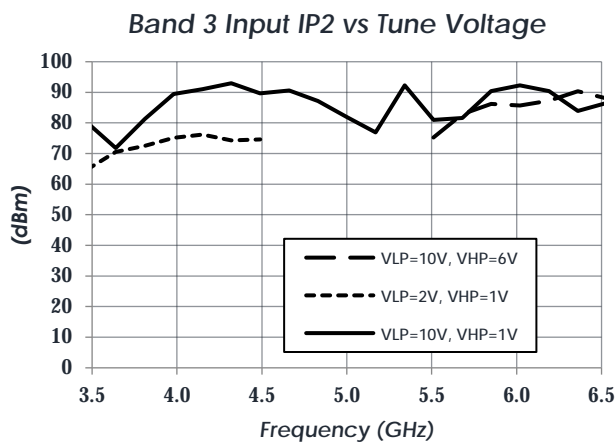
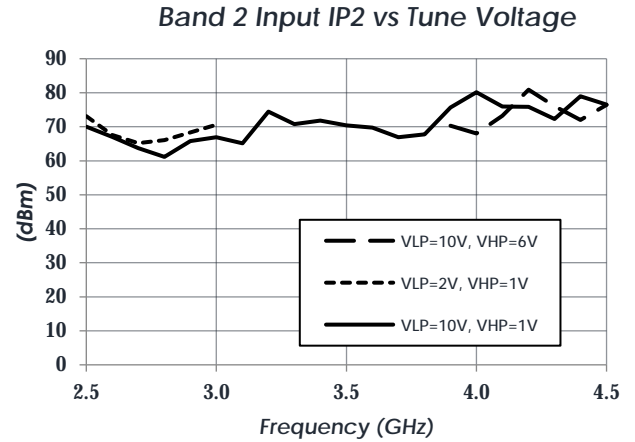
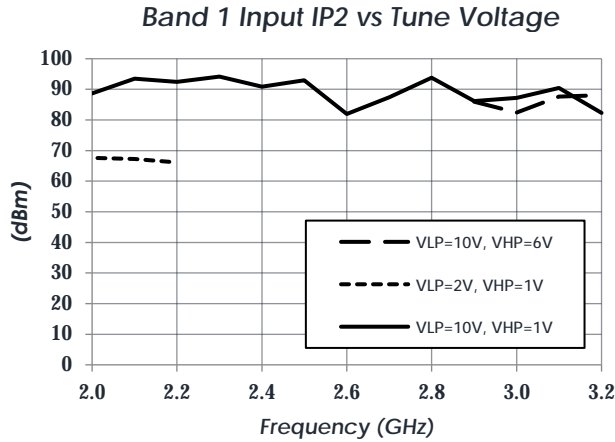

To obtain price, delivery, or to place an order contact [MMICSales@mercy.com](mailto:MMICSales@mercy.com)  
 Atlanta Micro Inc., 3720 Davinci Ct, Suite 125, Norcross, GA 30092 • Phone: (470) 253-7640 • [www.atlantamicro.com](http://www.atlantamicro.com)

# AM3089 – Filter Bank



Analog Tunable 2.0 to 18.0 GHz Bandpass

## Typical Application

Two Control Voltages

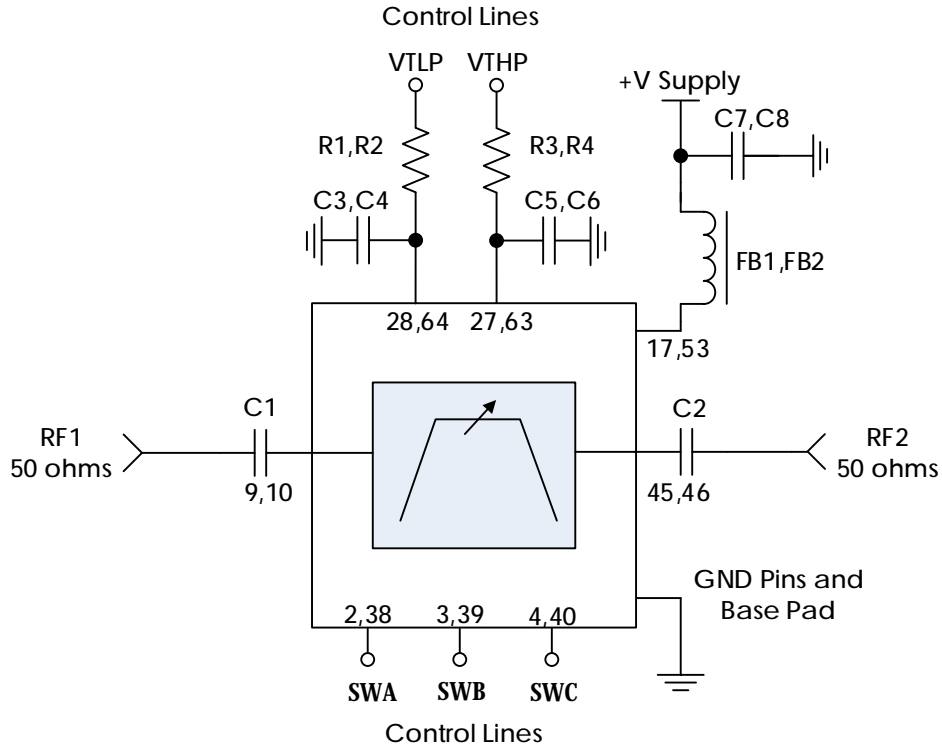

### Recommended Component List (or equivalent):

Part	Value	Part Number	Manufacturer
C1,C2	0.1 $\mu$ F	0402BB104KW160	Passives Plus
C3-C8	0.1 $\mu$ F	C1005X7R1H104K050BB	TDK
FB1,FB2		MMZ1005A222E	TDK
R1 – R4	100 $\Omega$	CRCW0402100RFKED	Vishay

### Notes:

1. RC filtering on the control lines is recommended to prevent digital noise from coupling to the RF path. Select control line RC filter values based on desired logic source decoupling and switching speed.

# AM3089 – Filter Bank



Analog Tunable 2.0 to 18.0 GHz Bandpass

## Alternate Application

Single Control Voltage

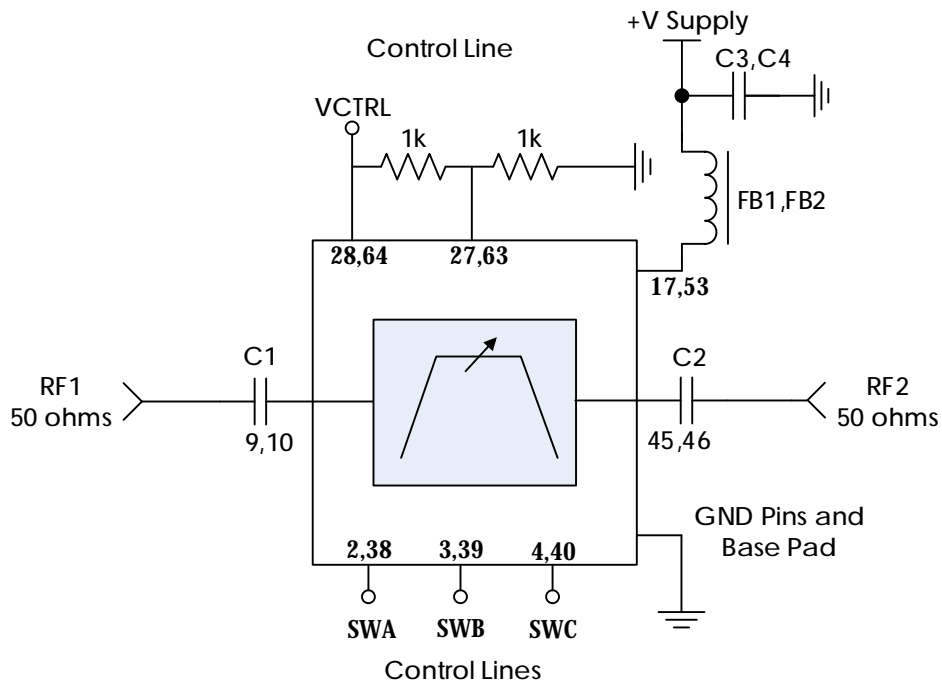

### Recommended Component List (or equivalent):

Part	Value	Part Number	Manufacturer
C1,C2	0.1 $\mu$ F	0402BB104KW160	Passives Plus
C3,C4	0.1 $\mu$ F	C1005X7R1H104K050BB	TDK
FB1,FB2		MMZ1005A222E	TDK

### Notes:

1. The resistive divider between pins 28/64 and 27/63 exists to normalize percentage bandwidth over the full +0.5V to +10V range.
  - a. Tying pins 28/64 and 27/63 to the same control voltage without the divider is possible, but the bandwidth will be narrower with higher insertion loss over the tuning range
2. RC filtering on the control lines is recommended to prevent digital noise from coupling to the RF path. Select control line RC filter values based on desired logic source decoupling and switching speed.

# AM3089 – Filter Bank

Analog Tunable 2.0 to 18.0 GHz Bandpass

## Evaluation PC Board

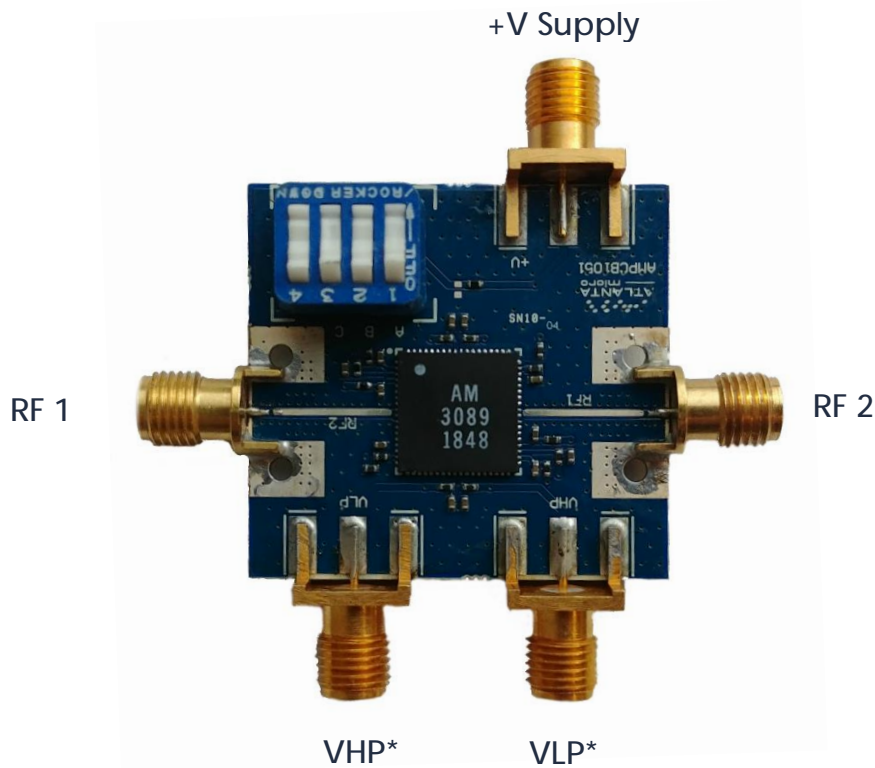

\*Note: VLP and VHP are opposite of what is shown on the silkscreen for the PCB.

## Related Parts

Part Number	Description			
AM3063	6.0 GHz	to	18.0 GHz	Digitally Tunable Bandpass Filter Bank
AM3064	1.0 GHz	to	6.5 GHz	Digitally Tunable Bandpass Filter Bank
AM3066	12.0 GHz	to	26.5 GHz	Digitally Tunable Bandpass Filter Bank
AM3134	2.0 GHz	to	4.5 GHz	Analog Tunable Bandpass Filter Bank
AM3135	3.5 GHz	to	9.0 GHz	Analog Tunable Bandpass Filter Bank
AM3136	8.0 GHz	to	19.0 GHz	Analog Tunable Bandpass Filter Bank
AM3099	2.0 GHz	to	18.0 GHz	Analog Tunable Bandpass Filter Bank
AM3137	700 MHz	to	2.0 GHz	Analog Tunable Notch Filter Bank
AM3138	1.3 GHz	to	3.25 GHz	Analog Tunable Notch Filter Bank
AM3139	2.5 GHz	to	6.0 GHz	Analog Tunable Notch Filter Bank

To obtain price, delivery, or to place an order contact [MMICSales@mrcty.com](mailto:MMICSales@mrcty.com)  
Atlanta Micro Inc., 3720 Davinci Ct, Suite 125, Norcross, GA 30092 • Phone: (470) 253-7640 • [www.atlantamicro.com](http://www.atlantamicro.com)

# AM3089 – Filter Bank

Analog Tunable 2.0 to 18.0 GHz Bandpass

## AM3089 / AM3099 Compatibility Application Note

### Recommended Application Circuit

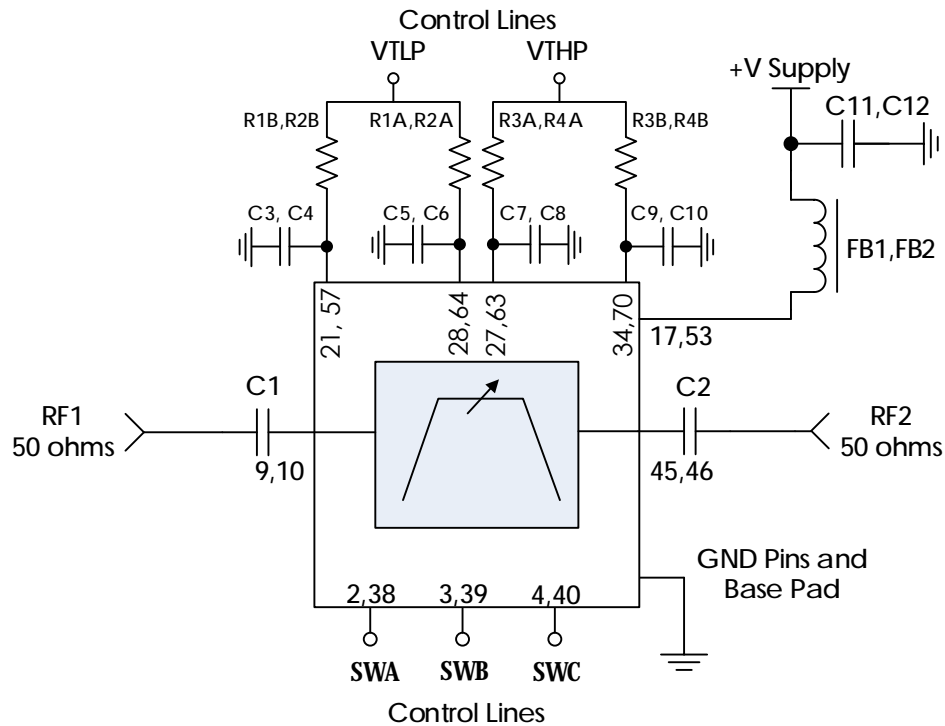

### Recommended Component List (or equivalent):

Part	Value	Part Number	Manufacturer
C1,C2	0.1 $\mu$ F	0402BB104KW160	Passives Plus
C3 – C12	0.1 $\mu$ F	C1005X7R1H104K050BB	TDK
FB1,FB2		MMZ1005A222E	TDK

Part	AM3089	AM3099
R1A – R4A	100 $\Omega$	Do Not Install
R1B – R4B	Do Not Install	100 $\Omega$

### Notes:

1. RC filtering on the control lines is recommended to prevent digital noise from coupling to the RF path. Select control line RC filter values based on desired logic source decoupling and switching speed.
2. AM3099 is the AM3089 packaged in a 10mm plastic package with slightly increased bandwidth. Inquire for more details.



# AM3089 – Filter Bank

Analog Tunable 2.0 to 18.0 GHz Bandpass

## Recommended Pinout Modification

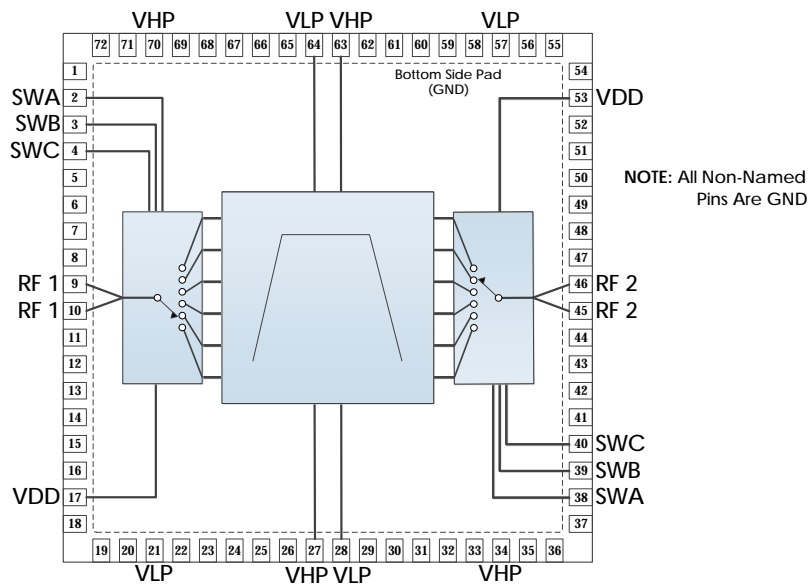

Pin Number	Pin Name	AM3089 Pin Function	AM3099 Pin Function
27	VHP	AM3089 High Pass DC Control	Ground – Common <sup>1</sup>
28	VLP	AM3089 Low Pass DC Control	Ground – Common <sup>1</sup>
63	VHP	AM3089 High Pass DC Control	Ground – Common <sup>1</sup>
64	VLP	AM3089 Low Pass DC Control	Ground – Common <sup>1</sup>
21	VLP	Not Connected	AM3099 Low Pass DC Control
34	VHP	Not Connected	AM3099 High Pass DC Control
57	VLP	Not Connected	AM3099 Low Pass DC Control
70	VHP	Not Connected	AM3099 High Pass DC Control

**Note 1:** Pins must either be floating or connected to ground. When transitioning to AM3099 from AM3089 it is easiest to leave these not connected.

**Note 2:** All other pins are common between AM3089 and AM3099, refer to pinout on page 3.

### Component Compliance Information

**RoHS:** Atlanta Micro, Inc. hereby certifies that all products comply with the EC Directive 2011/65/EC on the Restriction of Hazardous Substances, commonly known as RoHS II. All products supplied by Atlanta Micro shall be compliant with the European Directive 2011/65/EC based on the following substance list.

Substance List	Allowable Maximum Concentration
Lead (Pb)	<1000 PPM (0.1% by weight)
Mercury (Hg)	<1000 PPM (0.1% by weight)
Cadmium (Cd)	<75 PPM (0.0075% by weight)
Hexavalent Chromium (CrVI)	<1000 PPM (0.1% by weight)
Polybrominated Biphenyls (PBB)	<1000 PPM (0.1% by weight)
Polybrominated Diphenyl ethers (PBDE)	<1000 PPM (0.1% by weight)
Decabromodiphenyl Deca BDE	<1000 PPM (0.1% by weight)

**REACH:** Atlanta Micro, Inc. neither uses nor intentionally adds any of the substances considered to be a Substance of Very High Concern (SVHC) as defined by the EU Regulation (EC) No. 1907-2006 on Registration, Evaluation, Authorization, and Restriction of Chemicals (REACH).

**Conflict Materials:** Atlanta Micro does not knowingly use materials that are sourced from the Democratic Republic of Congo (DRC) or any other known conflict regions. Atlanta Micro's supply chain is comprised of sources that are both environmentally and socially responsible. We periodically review this requirement with our vendors to ensure continued compliance.

Atlanta Micro takes its responsibility as a global partner seriously and will use due diligence within our supply chain to ensure all standards are met to the best of our knowledge.