

AM2005 – Attenuator

DC to 20 GHz, 31 dB, 5-Bit

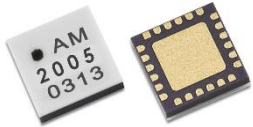

AM2005 is a 31dB 5-Bit digital attenuator covering the DC to 20 GHz frequency range in 1-dB steps. The device provides low insertion loss, flat frequency response, and low attenuation error over the operating temperature range of -40C to +85C.

FEATURES

- 1 dB steps up to 31 dB
- 2.5 dB Insertion Loss
- Integrated Control Line Filtering
- +3.3V or +5V Supply
- +3V or +5V Control
- +40 dBm IP3
- 4mm QFN Package
- -40C to +85C Operation

FUNCTIONAL DIAGRAM

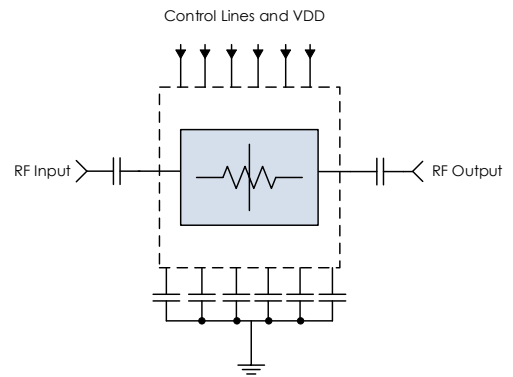

CHARACTERISTIC PERFORMANCE

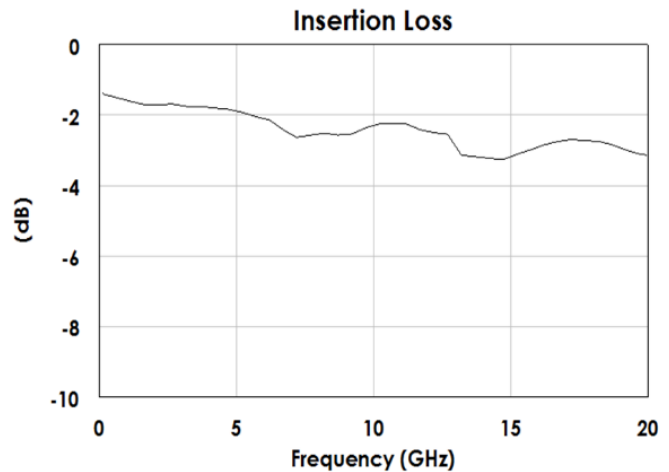
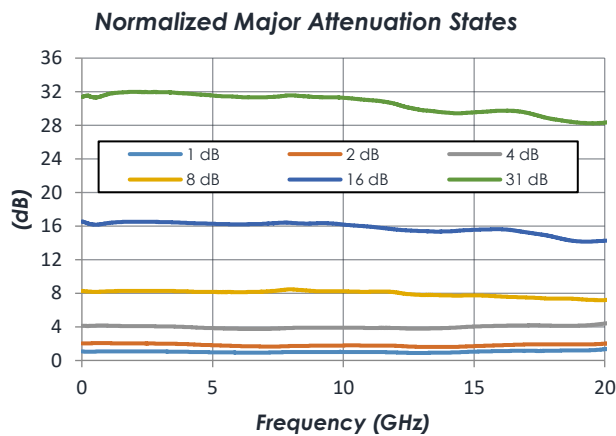

CONTENTS

FEATURES 1

FUNCTIONAL DIAGRAM 1

CHARACTERISTIC PERFORMANCE 1

REVISION HISTORY..... 2

PIN LAYOUT AND DEFINITIONS 3

SPECIFICATIONS..... 5

TYPICAL PERFORMANCE 7

TYPICAL APPLICATION..... 9

RECOMMENDED COMPONENT LIST (OR EQUIVALENT) 9

EVALUATION PC BOARD..... 10

RELATED PARTS 10

COMPONENT COMPLIANCE INFORMATION 11

REVISION HISTORY

Date	Revision	Notes
May 15, 2020	6	Updated Datasheet Format.
October 9, 2020	7	Added Attenuation Error Plot.
December 13, 2022	8	Added Return Loss, Step Error, and Relative Phase Plots.
June 13, 2024	9	Changed to Mercury branding. No content changes.
May 6, 2026	9.01	Minor formatting changes.

PIN LAYOUT AND DEFINITIONS

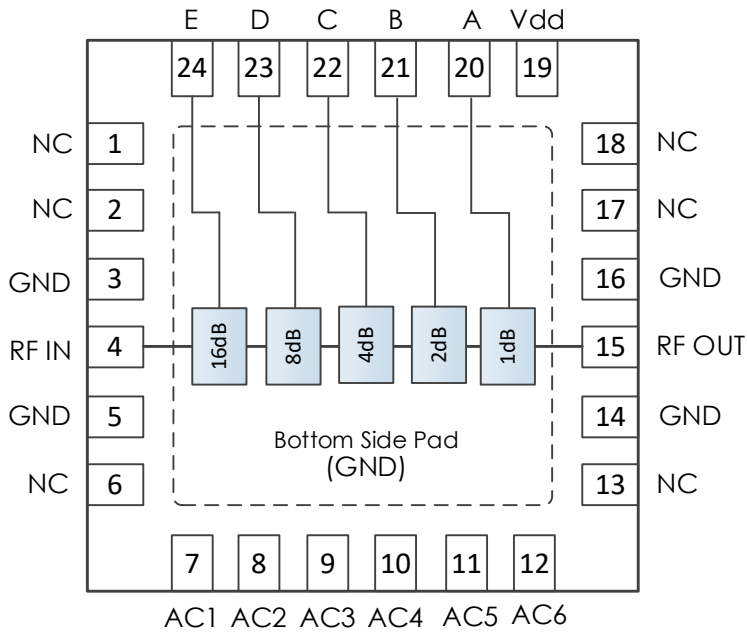

Pin	Name	Function
1-2	NC	No Connect*
3	GND	Ground - Common
4	RF IN	RF Input - 50 Ohms - DC Coupled, External DC blocking capacitor required**
5	GND	Ground - Common
6	NC	No Connect*
7	AC1	Optional AC ground***
8	AC2	Optional AC ground***
9	AC3	Optional AC ground***
10	AC4	Optional AC ground***
11	AC5	Optional AC ground***
12	AC6	Optional AC ground***

* NC pins may be left open or connected to ground

** DC Blocking caps not required if in series with other Atlanta Micro parts of the same reference voltage.

*** AC Ground caps optional. Installing AC ground capacitors offer optimum performance below 400 MHz.

PIN LAYOUT AND DEFINITIONS (CONTINUED)

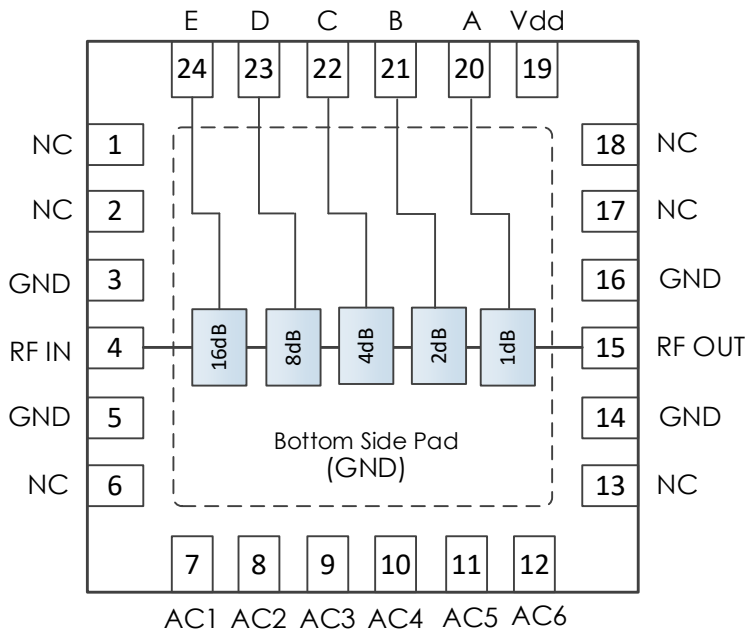

Pin	Name	Function
13	NC	No Connect*
14	GND	Ground - Common
15	RF OUT	RF Output – 50 Ohms – DC Coupled, External DC blocking capacitor required**
16	GND	Ground - Common
17-18	NC	No Connect*
19	Vdd	DC Power Input
20	A	Attenuator Control Bit A
21	B	Attenuator Control Bit B
22	C	Attenuator Control Bit C
23	D	Attenuator Control Bit D
24	E	Attenuator Control Bit E

* NC pins may be left open or connected to ground

** DC Blocking caps not required if in series with other Mercury parts of the same reference voltage.

SPECIFICATIONS

Absolute Maximum Ratings

	Minimum	Maximum
Supply Voltage	-0.3 V	6.0 V
RF Input Power		+17dBm
Operating Junction Temperature	-40 C	+150 C
Storage Temperature Range	-55 C	+150 C

Note: Any device operation beyond the Absolute Maximum Ratings may result in permanent damage to the device. The values listed in this table are extremes and do not imply functional operation of the device at these or any other conditions beyond what is listed under Recommended Operating Conditions. Any part subjected to conditions outside of what is recommended for an extended amount of time may suffer from reliability concerns.

Handling Information

	Minimum	Maximum
Storage Temperature Range (Recommended)	-50 C	+125 C
Moisture Sensitivity Level	MSL 1	



Mercury products are electrostatic sensitive. Follow safe handling practices to avoid damage.

Recommended Operating Conditions

	Minimum	Typical	Maximum
Supply Voltage	+3.0 V	+5.0 V	+5.2 V
Operating Case Temperature	-40 C		+85 C
Operating Junction Temperature	-40 C		+125 C

DC Electrical Characteristics

(T = 25 °C unless otherwise specified)

Param	Testing Conditions	Min	Typical	Max
DC Supply Voltage		+3.0 V	+5.0 V	+5.2 V
DC Supply Current	Vdd = +5.0 V		3.3 mA	4.5 mA
Power Dissipated	Vdd = +5.0 V		16.5 mW	
Logic Level Low		0.0 V		+0.5 V
Logic Level High		+2.0 V		+5.0 V

RF Performance

(T = 25 °C unless otherwise specified)

Param	Testing Conditions	Min	Typical	Max
Frequency Range		DC		20 GHz
Insertion Loss	f = 5 GHz		-2 dB	
	f = 15 GHz		-3 dB	
Return Loss			-15 dB	
Output IP3			+40 dBm	

Timing Characteristics

Param	Min	Typical	Max
0 dB to 31 dB 50% CTL to 10% RF		100 ns	
31 dB to 0 dB 50% CTL to 90% RF		300 ns	
50% CTL to RF Envelope Change		20 ns	

State Table

E	D	C	B	A	Attenuation (dB)
L	L	L	L	L	Insertion Loss
L	L	L	L	H	1
L	L	L	H	L	2
L	L	H	L	L	4
L	H	L	L	L	8
H	L	L	L	L	16
H	H	H	H	H	31

TYPICAL PERFORMANCE

(VDD = +3.3V, T = 25°C unless otherwise specified)

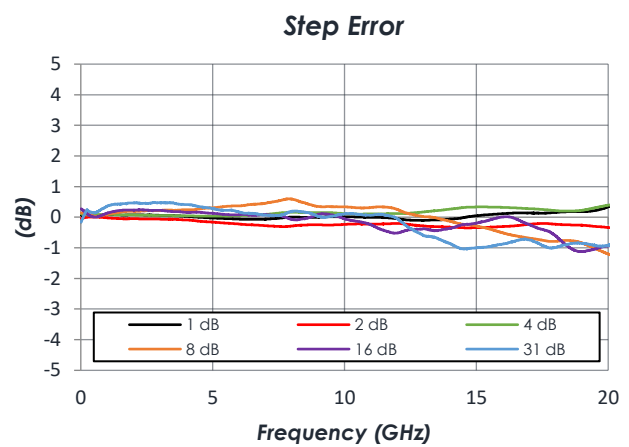
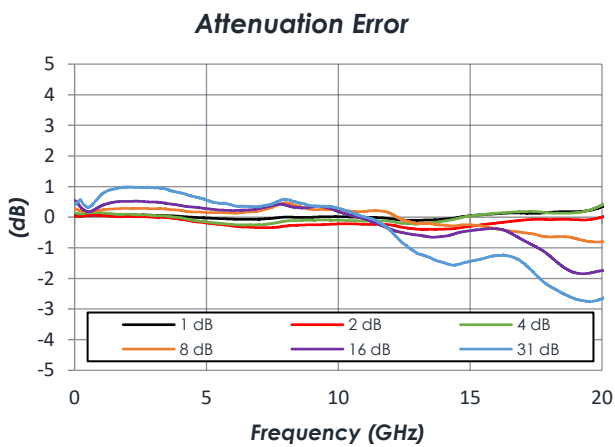
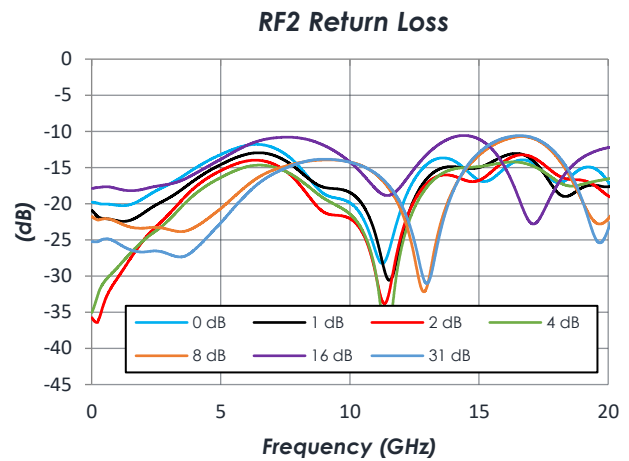
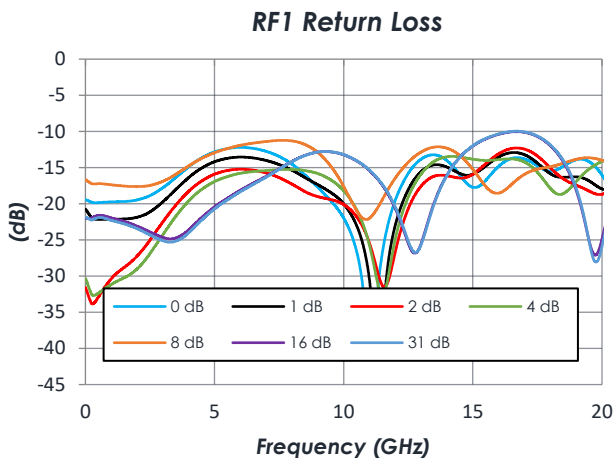
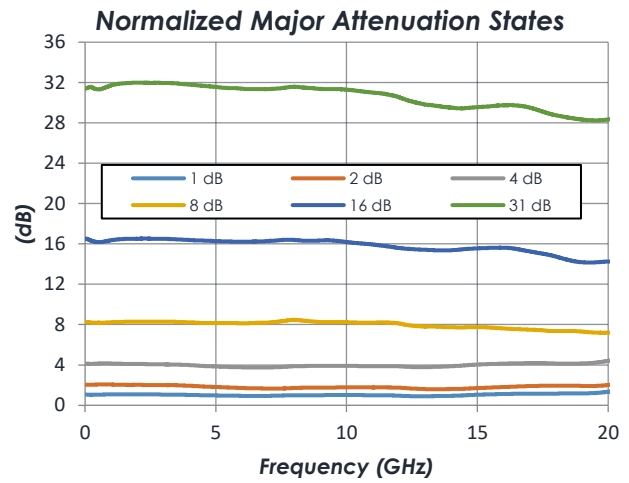
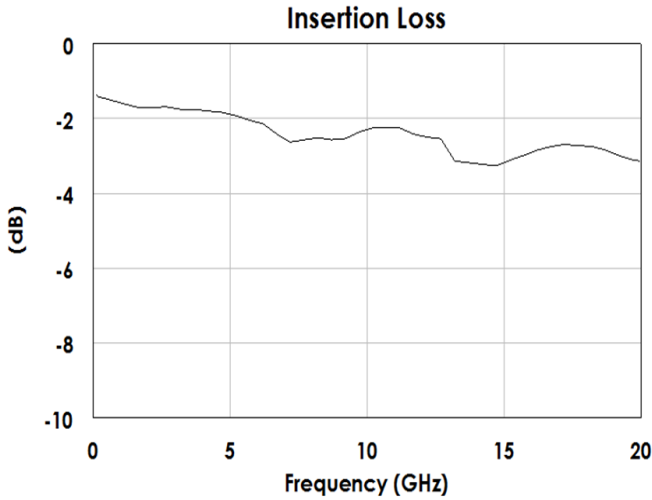

PIN LAYOUT AND DEFINITIONS (CONTINUED)

(VDD = +3.3V, T = 25°C unless otherwise specified)

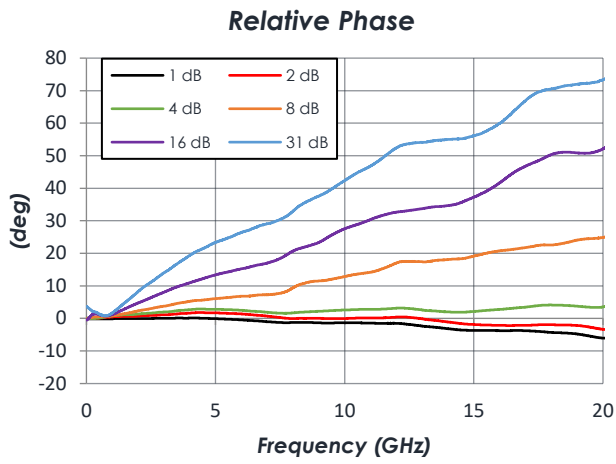

TYPICAL APPLICATION

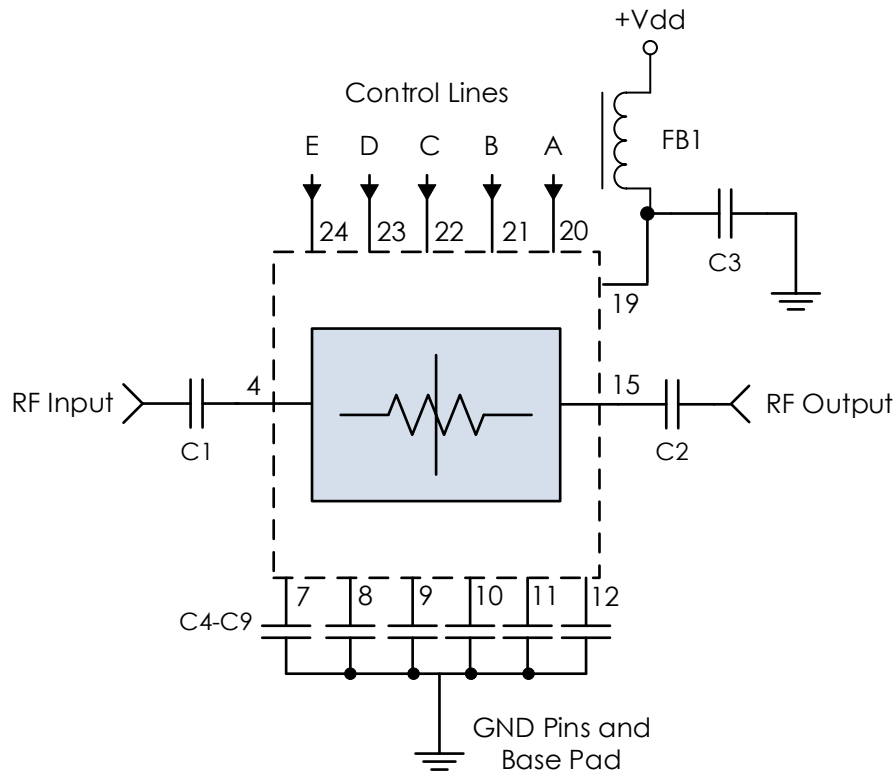

RECOMMENDED COMPONENT LIST (OR EQUIVALENT)

Part	Value	Part Number	Manufacturer
C1, C2	0.1 μ F	0201BB104KW160	Passives Plus
C3 - C9	0.1 μ F	C1005X7R1H104K050BB	TDK
FB1	-	MMZ1005A222E	TDK

Notes:

1. DC blocking capacitors should be high performance, low-loss, broadband capacitors for optimum performance.
2. VDD and control lines filtered internally to provide high frequency isolation.
3. C4 through C9 are only required for operation below 400 MHz.

EVALUATION PC BOARD

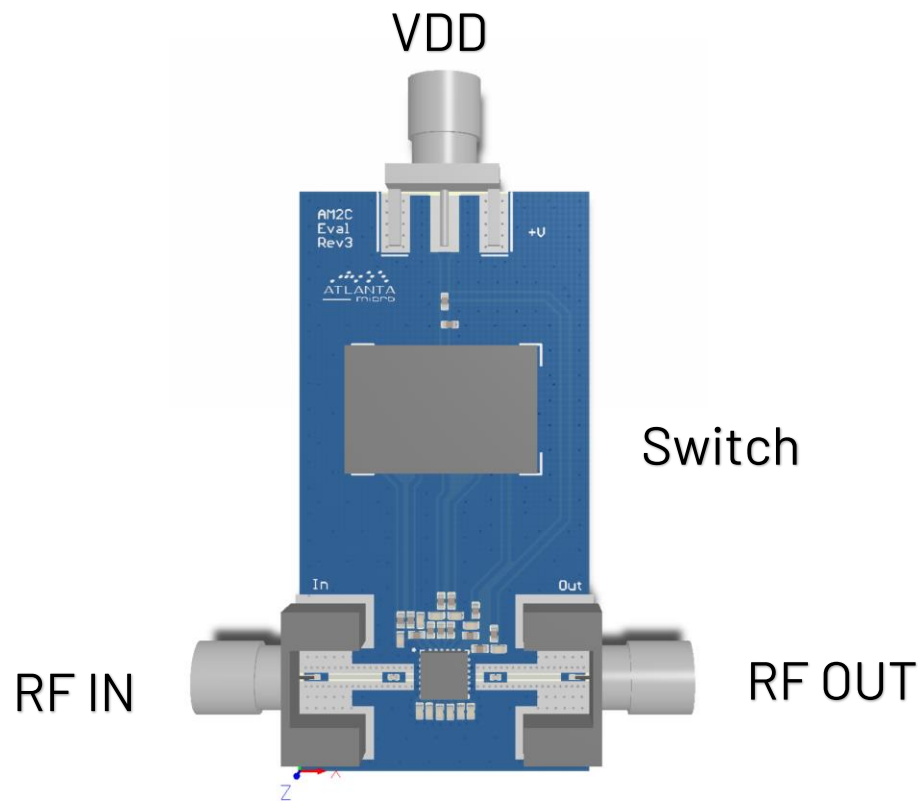

RELATED PARTS

Part Number	Description	
AM2010	DC to 30 GHz	Digital Step Attenuator

COMPONENT COMPLIANCE INFORMATION

RoHS: Mercury Systems, Inc. hereby certifies that all products comply with the EC Directive 2011/65/EC on the Restriction of Hazardous Substances, commonly known as EU-RoHS 6 and 10. All products supplied by Mercury shall be compliant with the European Directive 2011/65/EC based on the following substance list.

Substance List	Allowable Maximum Concentration
Lead (Pb)	<1000 PPM (0.1% by weight)
Mercury (Hg)	<1000 PPM (0.1% by weight)
Cadmium (Cd)	<75 PPM (0.0075% by weight)
Hexavalent Chromium (CrVI)	<1000 PPM (0.1% by weight)
Polybrominated Biphenyls (PBB)	<1000 PPM (0.1% by weight)
Polybrominated Diphenyl ethers (PBDE)	<1000 PPM (0.1% by weight)
Decabromodiphenyl Deca BDE	<1000 PPM (0.1% by weight)
Bis (2-ethylhexyl) Phthalate (DEHP)	<1000 PPM (0.1% by weight)
Butyl Benzyl Phthalate (BBP)	<1000 PPM (0.1% by weight)
Dibutyl Phthalate (DBP)	<1000 PPM (0.1% by weight)
Diisobutyl Phthalate (DIBP)	<1000 PPM (0.1% by weight)

REACH: Mercury Systems, Inc. neither uses nor intentionally adds any of the substances considered to be a Substance of Very High Concern (SVHC) as defined by the EU Regulation (EC) No. 1907-2006 on Registration, Evaluation, Authorization, and Restriction of Chemicals (REACH).

CONFLICT MATERIALS: Mercury does not knowingly use materials that are sourced from the Democratic Republic of Congo (DRC) or any other known conflict regions. Mercury’s supply chain is comprised of sources that are both environmentally and socially responsible. We periodically review this requirement with our vendors to ensure continued compliance.

Mercury takes its responsibility as a global partner seriously and will use due diligence within our supply chain to ensure all standards are met to the best of our knowledge.



Corporate Headquarters

50 Minuteman Road
 Andover, MA 01810 USA
 +1 978.967.1401 tel
 +1 866.627.6951 tel
 +1 978.256.3599 fax

International Headquarters

Mercury International
 Avenue Eugène-Lance, 38
 PO Box 584
 CH-1212 Grand-Lancy 1
 Geneva, Switzerland
 +41 22 884 5100 tel

Learn more

Visit: mrcy.com
 For pricing details, contact: MMICsales@mrcy.com
 For technical details, contact: MMICsupport@mrcy.com



The Mercury Systems logo is a registered trademark of Mercury Systems, Inc. Other marks used herein may be trademarks or registered trademarks of their respective holders. Mercury products identified in this document conform with the specifications and standards described herein. Conformance to any such standards is based solely on Mercury’s internal processes and methods. The information contained in this document is subject to change at any time without notice.

