

Ensemble 5000 Series VXS SFM5100 Switch Module

Serial RapidIO/GigE Switching, System Management, and Front-Panel I/O in a Single Slot

- Full inter-board serial RapidIO® and Gigabit Ethernet connections in a VXS system
- VITA 41.2 compliant
- Enhanced bandwidth with 3.125 Gbaud serial RapidIO data rates
- Intelligently manages the entire system

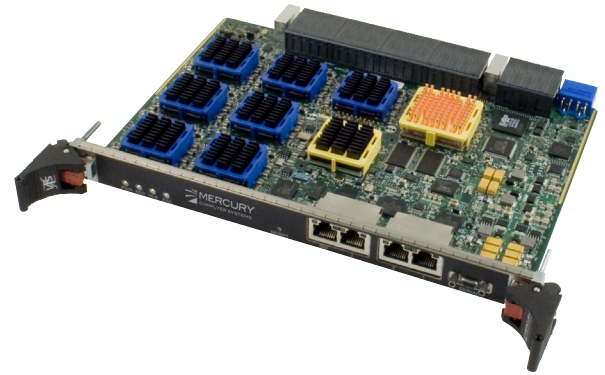

The Ensemble™ 5000 Series VXS SFM5100 Switch Module from Mercury Computer Systems is a VITA 41-compliant switch board that provides full inter-board serial RapidIO and Gigabit Ethernet connections in a VXS system. The module has seven 8-port serial RapidIO crossbars in a two-level hierarchy, providing full connectivity for up to 18 VXS payload modules at up to 1.25 GB/s per link in both directions simultaneously. Additionally, the SFM5100 provides Gigabit Ethernet switching for up to 18 VXS payload slots via the onboard Broadcom® BCM56312 Level 2 managed switch. Up to two front-panel Gigabit Ethernet ports are available, allowing external Ethernet traffic to access to the backplane Ethernet links. The SFM5100 implements VXS system management capabilities, allowing it to intelligently manage the entire system from a single point.

Full-Featured Switch-Fabric Technology per VITA 41.2

The SFM5100 utilizes seven Tundra® Tsi578™ serial RapidIO crossbars to create a dual-star switching hierarchy between VXS payload slots per VITA 41.2. All crossbars provide a full-duplex, x4 link on each of their eight ports. The crossbars can be configured to operate at 3.125 Gbaud for enhanced serial RapidIO bandwidth, or 2.5 Gbaud for backward-compatibility. Each Tsi578 crossbar has its own configuration EEPROM, allowing for decreased EEPROM load times and parallel crossbar configuration. The SFM5100 implements three inter-switch serial RapidIO links for switch-to-switch communication.

A single SFM5100 provides full connectivity for up to 18 payload modules in a VXS chassis. A second SFM5100 can be configured as an additional full-duplex connection for payload modules. Alternatively, dual SFM5100 configurations can be configured for redundant switching. Software from Mercury enables user applications to reroute serial RapidIO traffic from one switch to the other upon detection of an interruption of service.

Gigabit Ethernet Switching per VITA 41.6

The SFM5100 is the first VXS switch module in the industry to provide Gigabit Ethernet switching per the VITA 41.6 standard. The SFM5100 implements the Broadcom BCM56312 switch to provide Gigabit Ethernet connectivity over the VXS backplane to each payload module. System designers can avoid the need for an external Gigabit Ethernet switch and cabling in their configurations, because the SFM5100 embeds this functionality within the VXS system.

With the assistance of the SFM5100's onboard service processor, the switch can be configured as a Level 2 managed switch, enabling such features as multicast support via IGMP, Rapid Spanning Tree Protocol (RSTP) support, and support for Jumbo packets.

The SFM5100 enhances interoperability by providing an inter-switch 10 Gigabit Ethernet connection that allows the module to communicate seamlessly via standard TCP/IP to either another SFM5100 module or another switch module architecture that has a similar 10 Gigabit Ethernet connection.

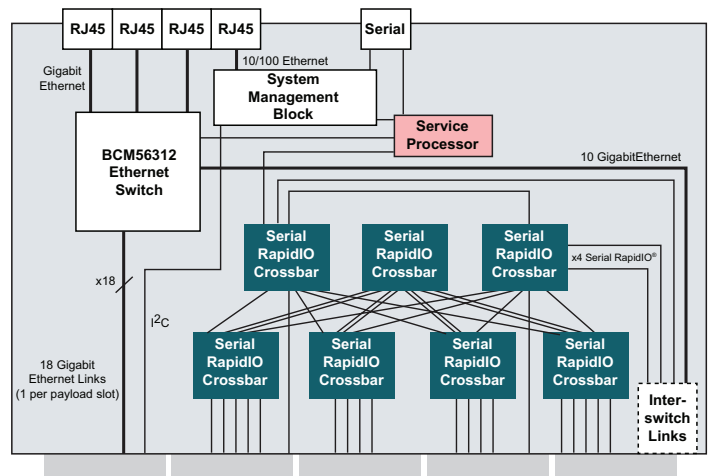

Figure 1. VXS SFM5100 Switch Module block diagram

Front-Panel Gigabit Ethernet Ports

The SFM5100 provides up to two Gigabit Ethernet ports to the front panel. This allows users to direct TCP/IP traffic directly into the onboard Gigabit Ethernet switch for dispersal among the VXS payload modules. It also enables easy integration of the VXS system into the network backbone of the deployed platform.

Onboard System Management

An onboard system management block allows the SFM5100 to manage the entire VXS system. The onboard shelf manager can query sensor values across the system, reset and power modules up or down, set sensor thresholds, and manage firmware updates. Network access to the management subsystem is provided via a front-panel 10/100BASE-T port. This management plane is implemented in accordance with the VITA 41 base standard, which describes the routing of an I2C bus over the VXS switch connectors.

Flexible, Modular System Configurations

Mercury's VXS systems are designed to the system level, with a rich set of fully integrated modules that can be flexibly scaled and combined in a variety of configurations to meet a broad range of embedded application requirements. Many board types are available for end-to-end solutions, including a variety of RF tuners, digital receivers, and single-board computers (SBCs).

A fully loaded VXS system that balances processing power with flexible I/O capabilities consists of 18 VXS-220P Modules and two SFM5100 Switch Modules, although not all chassis can

support this maximum configuration. This maximum configuration supports up to 36 MPC8641D dual-core processing devices (72 cores) in a single chassis, for up to 768 GFLOPS of processing (assuming 1.33-GHz processor clock speed), with over 45 GB/s of both aggregate and bisection bandwidth via the RapidIO switch fabric. The equivalence of the aggregate bandwidth and bisection bandwidth figures indicates that locality of processing within the system is not a factor when mapping an algorithm to the multicomputer – the processing resources are, in essence, positionless.

SFM5100 Switch Modules are available in versions that meet commercial, vibration/humidity (VH), and Level 1 rugged environmental specifications.

VXS Performance with VME Compatibility

The VXS standard simplifies the migration of existing VME systems to solutions that can support next-generation requirements without abandoning legacy modules. VXS maintains pin compatibility with VME64's P1 and P2 connectors and conforms to VME's standard IEEE 1101 mechanical specification. VXS adds high-speed serial fabric capability on the Tyco MultiGigRT2 P0 connector, mating with backplane connector J0. The VXS P0 connector improves upon the historical VME64x P0 option, while maintaining VME64 compatibility. Switch modules such as the SFM5100 provide VXS payload modules with the ability to scale to large systems capable of handling the most challenging computing problems.

Specifications

Features

Supports up to 18 VXS payload modules

Data plane (per VITA 41.2)

18 x4 serial RapidIO links at either 3.125 or 2.5 Gbaud
to payload slots

3 inter-switch serial RapidIO links

Control plane (per VITA 41.6)

18 Gigabit Ethernet links to payload slots

Single 10 Gigabit Ethernet inter-switch link

Management plane (per VITA 41)

I²C bus between all switch and payload slots

Front panel I/O via up to 2 Gigabit Ethernet ports

Dual-sided PCB assembly

Designed for installation in VITA 41 (VXS) compliant

COTS chassis

Dimensions

Standard VME/VXS

Double-height 6U form factor

160 mm x 233.3 mm

Power requirements

Input voltage 5V from backplane

Environmental

Please refer to Mercury publication “[Environmental Protections for Operation at the Tactical Edge](#)” for specific ruggedness levels and cooling options.

Some of Mercury's products are subject to the jurisdiction of the U. S. International Traffic in Arms Regulations (ITAR). Please contact your Mercury sales representative for more information.

Ensemble and Challenges Drive Innovation are trademarks of Mercury Computer Systems, Inc. RapidIO is a registered trademark of the RapidIO Trade Association. Other products mentioned may be trademarks or registered trademarks of their respective holders. Mercury Computer Systems, Inc. believes this information is accurate as of its publication date and is not responsible for any inadvertent errors. The information contained herein is subject to change without notice.

Copyright © 2009 Mercury Computer Systems, Inc.

2086.04E-1218-DS-SFM5100switch



INNOVATION THAT MATTERS™

CORPORATE HEADQUARTERS

50 Minuteman Road • Andover, MA 01810 USA
(978) 967-1401 • (866) 627-6951 • Fax (978) 256-3599

EUROPE MERCURY SYSTEMS, LTD

Unit 1 - Easter Park, Benyon Road, Silchester, Reading
RG7 2PQ United Kingdom
+ 44 0 1189 702050 • Fax + 44 0 1189 702321

www.mrcy.com