

AM2010 – Attenuator

DC to 30 GHz, 31 dB, 5-Bit

Description

AM2010 is a wideband 31dB 5-Bit digital attenuator covering the DC to 30 GHz frequency range in 1-dB steps. The positive control device provides low insertion loss, flat frequency response, and low attenuation error over the operating temperature range of -40C to +85C. Packaged in a 4mm QFN with internal 50Ω matching, internal decoder circuitry, and drawing less than 2mA of current, the AM2010 is suited for low SWaP applications.

Features

- 1 dB steps up to 31 dB
- 3.3 dB Insertion Loss
- Integrated Control Line Filtering
- +3.3V or +5V Supply
- +3V or +5V Control
- +42 dBm IP3
- 6.3ns Control Line RC Constant
- 4mm QFN Package
- -40C to +85C Operation

Functional Diagram

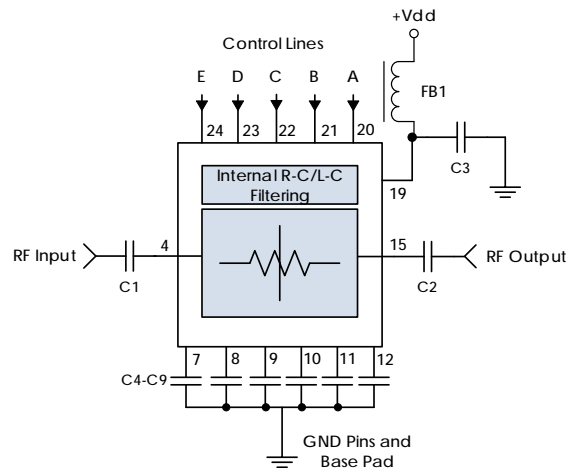

Characteristic Performance

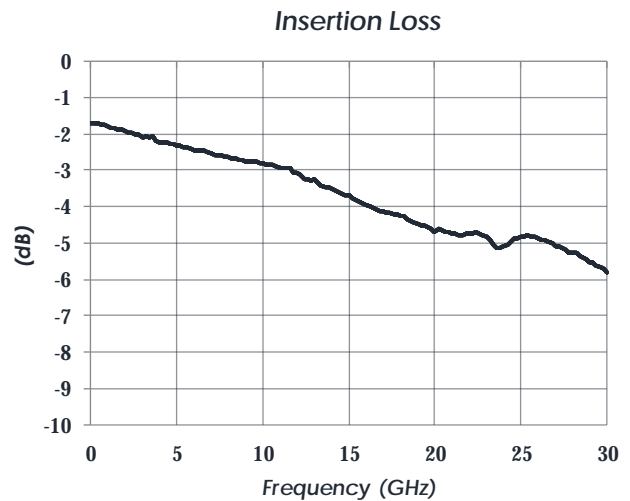
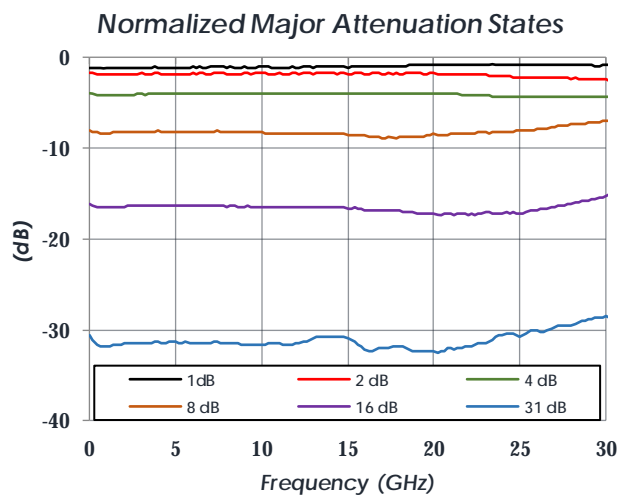

Table of Contents

Description.....	1	DC Electrical Characteristics	6
Features.....	1	RF Performance.....	6
Functional Diagram	1	Timing Characteristics	6
Characteristic Performance.....	1	State Table	6
Revision History	2	Typical Performance	7
Pin Layout and Definitions.....	3	Typical Application	9
Specifications.....	5	Evaluation PC Board.....	10
Absolute Maximum Ratings	5	Related Parts.....	10
Handling Information	5	Component Compliance Information	11
Recommended Operating Conditions ...	5		

Revision History

Date	Revision Number	Notes
October 22, 2020	1	Initial Release
November 11, 2020	2	Added Relative Step Error and Relative Phase Plots.
November 30, 2020	3	Increased Max Power Handling and Cleaned Relative Phase Plot.

AM2010 – Attenuator



DC to 30 GHz, 31 dB, 5-Bit

Pin Layout and Definitions

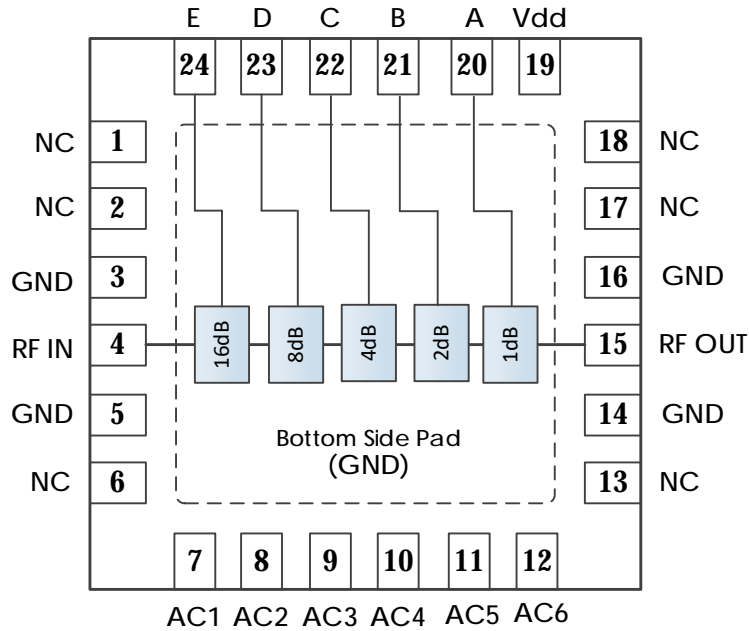

Pin Number	Pin Name	Pin Function
1-2	NC	No Connect*
3	GND	Ground - Common
4	RF IN	RF Input – 50 Ohms – DC Coupled, External DC blocking capacitor required**
5	GND	Ground - Common
6	NC	No Connect*
7	AC1	Optional AC ground***
8	AC2	Optional AC ground***
9	AC3	Optional AC ground***
10	AC4	Optional AC ground***
11	AC5	Optional AC ground***
12	AC6	Optional AC ground***

Notes:

* NC pins may be left open or connected to ground

** DC Blocking caps not required if in series with other Atlanta Micro parts of the same reference voltage

*** AC Ground caps optional. Installing AC ground capacitors offer optimum performance below 400 MHz.

AM2010 – Attenuator



DC to 30 GHz, 31 dB, 5-Bit

Pin Layout and Definitions (continued)

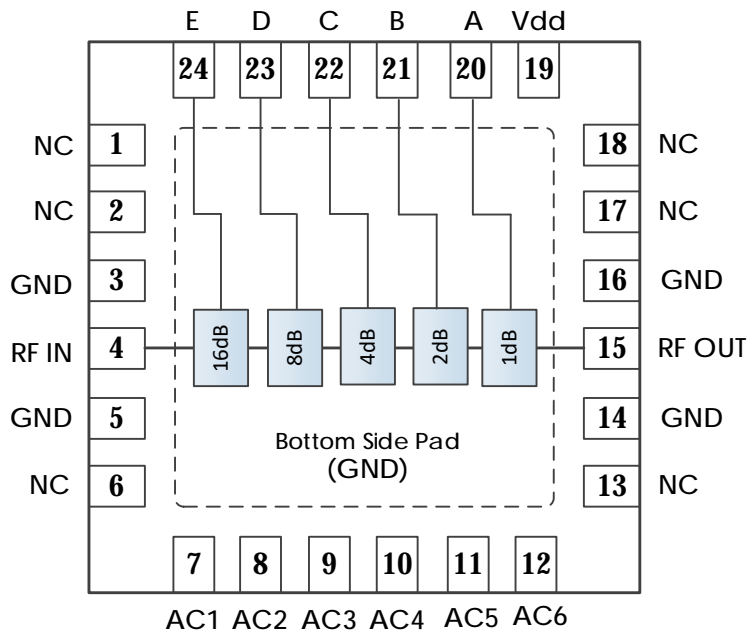

Pin Number	Pin Name	Pin Function
13	NC	No Connect*
14	GND	Ground - Common
15	RF OUT	RF Output – 50 Ohms – DC Coupled, External DC blocking capacitor required**
16	GND	Ground - Common
17-18	NC	No Connect*
19	Vdd	DC Power Input
20	A	Attenuator Control Bit A
21	B	Attenuator Control Bit B
22	C	Attenuator Control Bit C
23	D	Attenuator Control Bit D
24	E	Attenuator Control Bit E

Notes:

* NC pins may be left open or connected to ground

** DC Blocking caps not required if in series with other Atlanta Micro parts of the same reference voltage

AM2010 – Attenuator

DC to 30 GHz, 31 dB, 5-Bit

Specifications

Absolute Maximum Ratings

	Minimum	Maximum
Supply Voltage	-0.3 V	6.0 V
RF Input Power		+20dBm
Operating Junction Temperature	-40 C	+150 C
Storage Temperature Range	-55 C	+150 C

Note: Any device operation beyond the Absolute Maximum Ratings may result in permanent damage to the device. The values listed in this table are extremes and do not imply functional operation of the device at these or any other conditions beyond what is listed under Recommended Operating Conditions. Any part subjected to conditions outside of what is recommended for an extended amount of time may suffer from reliability concerns.

Handling Information

	Minimum	Maximum
Storage Temperature Range (Recommended)	-50 C	+125 C
Moisture Sensitivity Level	MSL 3	



Atlanta Micro products are electrostatic sensitive.
Follow safe handling practices to avoid damage

Recommended Operating Conditions

	Minimum	Typical	Maximum
Supply Voltage	+3.0 V	+3.3 V	+5.2 V
Operating Case Temperature	-40 C		+85 C
Operating Junction Temperature	-40 C		+125 C

AM2010 – Attenuator

DC to 30 GHz, 31 dB, 5-Bit

DC Electrical Characteristics

(VDD = +3.3V, T = 25°C unless otherwise specified)

Parameter	Testing Conditions	Minimum	Typical	Maximum
DC Supply Voltage		+3.0 V	+3.3 V	+5.2 V
DC Supply Current	Vdd = +3.3 V		1 mA	
Power Dissipated	Vdd = +3.3 V		5 mW	
Logic Level Low		0.0 V		+0.5 V
Logic Level High		+2.0 V		+5.0 V

RF Performance

(VDD = +3.3V, T = 25°C unless otherwise specified)

Parameter	Testing Conditions	Minimum	Typical	Maximum
Frequency Range		DC		26.5 GHz
Insertion Loss	f = 10 GHz		2.8 dB	
	f = 20 GHz		4.7 dB	
Return Loss			15 dB	
Output IP3			42 dBm	

Timing Characteristics

Parameter	Minimum	Typical	Maximum
0 dB to 31 dB 50% CTL to 10% RF		20 ns	
31 dB to 0 dB 50% CTL to 90% RF		60 ns	

State Table

E	D	C	B	A	Attenuation (dB)
L	L	L	L	L	Insertion Loss
L	L	L	L	H	1
L	L	L	H	L	2
L	L	H	L	L	4
L	H	L	L	L	8
H	L	L	L	L	16
H	H	H	H	H	31

AM2010 – Attenuator

DC to 30 GHz, 31 dB, 5-Bit

Typical Performance

(VDD = +3.3V, T = 25°C unless otherwise specified)

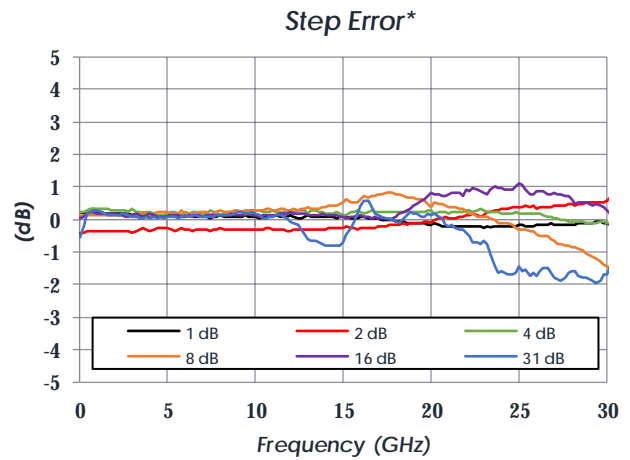
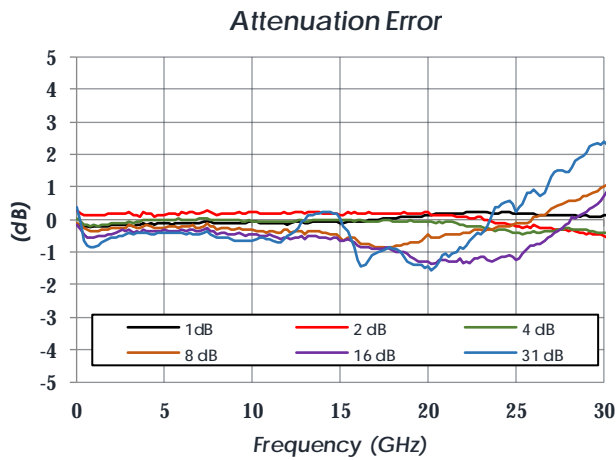
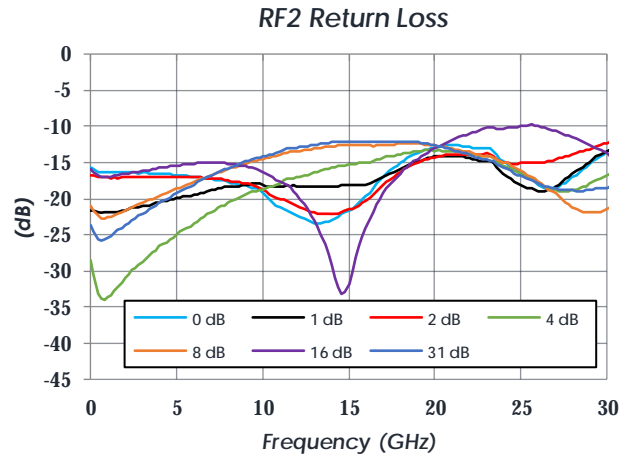
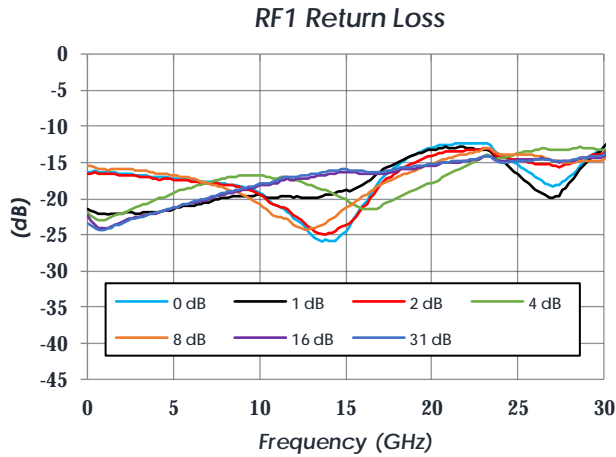
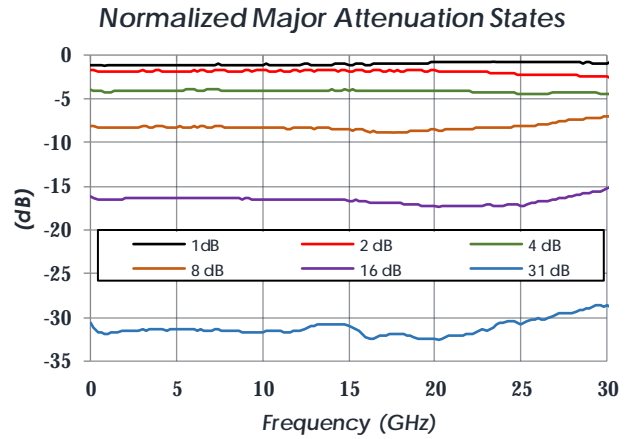
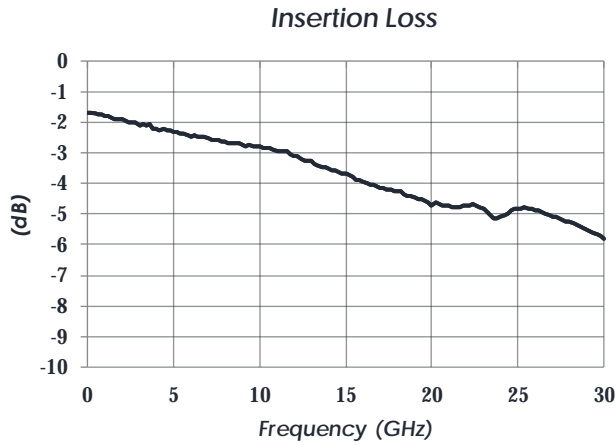

*Step Error defines error from one step to the subsequent step. I.e. the 1dB plot is the step error from 0 dB to 1dB.

AM2010 – Attenuator

DC to 30 GHz, 31 dB, 5-Bit

Typical Performance (continued)

(VDD = +3.3V, T = 25°C unless otherwise specified)

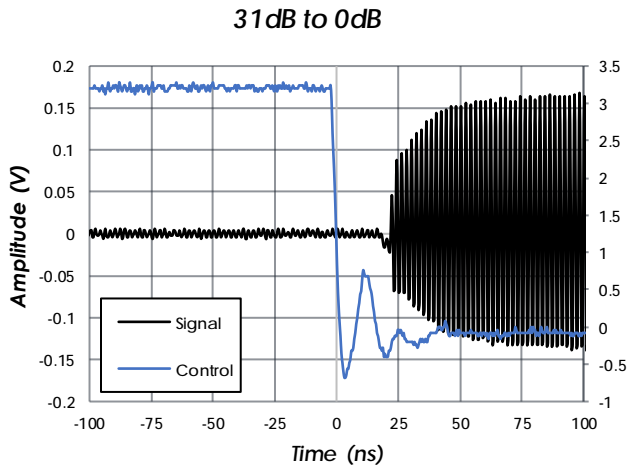
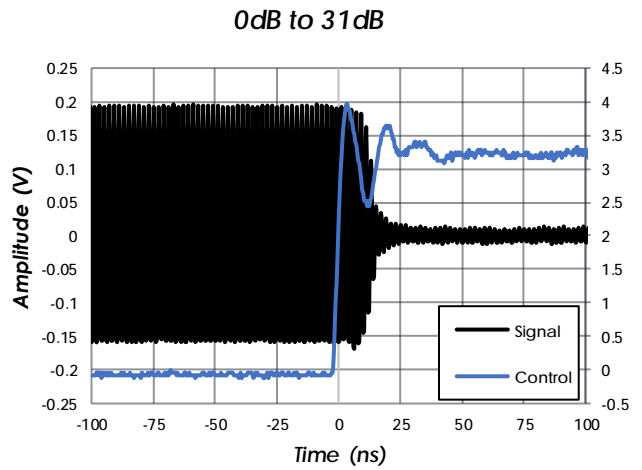
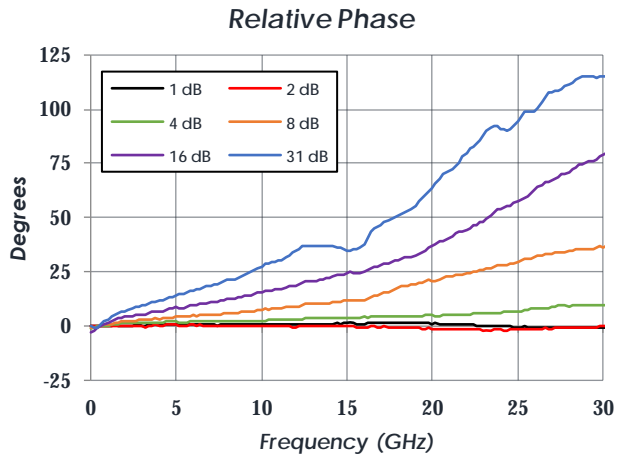

Typical Application

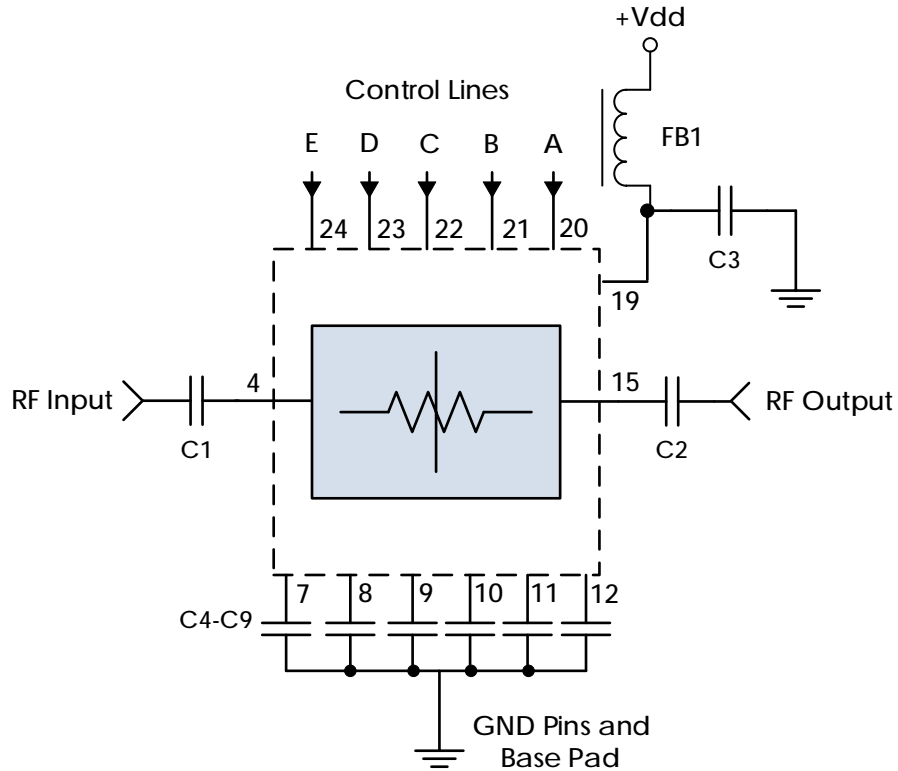

Recommended Component List (or equivalent):

Part	Value	Part Number	Manufacturer
C1, C2	0.1uF	0201BB104KW160	Passives Plus
C3 – C9	0.1uF	C1005X7R1H104K050BB	TDK
FB1	-	MMZ1005A222E	TDK

Notes:

1. DC blocking capacitors should be high performance, low-loss, broadband capacitors for optimum performance.
2. VDD and control lines filtered internally providing high frequency isolation up to 50+ GHz.
 - a. No additional RC filtering required on control lines.
 - b. 6.3ns Control Line RC Constant
3. C4 through C9 are only required for operation below 400 MHz.

AM2010 – Attenuator

DC to 30 GHz, 31 dB, 5-Bit

Evaluation PC Board

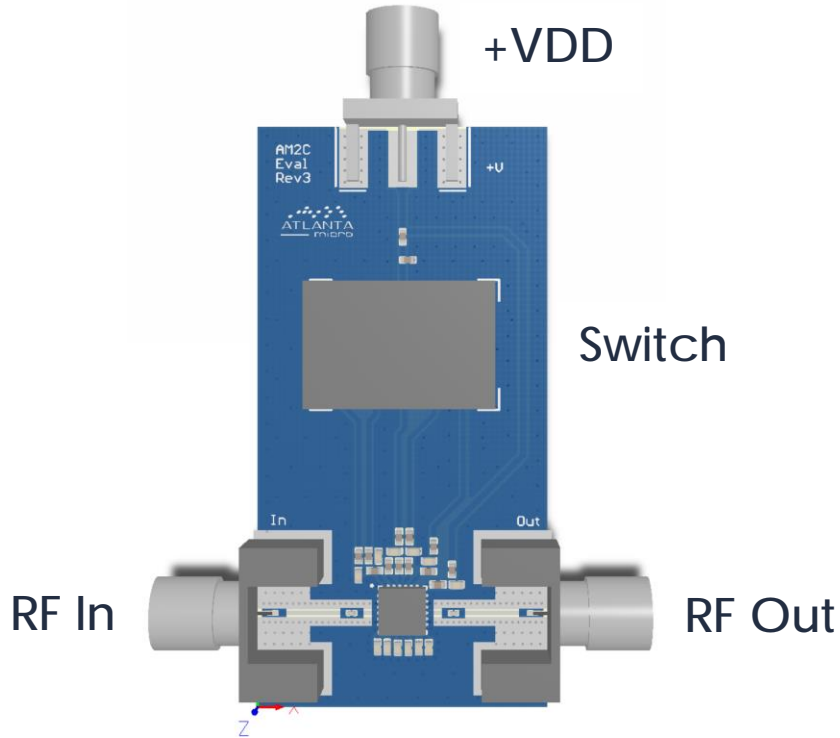

Related Parts

Part Number	Description
AM2005	DC to 20 GHz Digital Step Attenuator

Component Compliance Information

RoHS: Atlanta Micro, Inc. hereby certifies that all products comply with the EC Directive 2011/65/EC on the Restriction of Hazardous Substances, commonly known as EU-RoHS 6 and 10. All products supplied by Atlanta Micro shall be compliant with the European Directive 2011/65/EC based on the following substance list.

Substance List	Allowable Maximum Concentration
Lead (Pb)	<1000 PPM (0.1% by weight)
Mercury (Hg)	<1000 PPM (0.1% by weight)
Cadmium (Cd)	<75 PPM (0.0075% by weight)
Hexavalent Chromium (CrVI)	<1000 PPM (0.1% by weight)
Polybrominated Biphenyls (PBB)	<1000 PPM (0.1% by weight)
Polybrominated Diphenyl ethers (PBDE)	<1000 PPM (0.1% by weight)
Decabromodiphenyl Deca BDE	<1000 PPM (0.1% by weight)
Bis (2-ethylhexyl) Phthalate (DEHP)	<1000 PPM (0.1% by weight)
Butyl Benzyl Phthalate (BBP)	<1000 PPM (0.1% by weight)
Dibutyl Phthalate (DBP)	<1000 PPM (0.1% by weight)
Diisobutyl Phthalate (DIBP)	<1000 PPM (0.1% by weight)

REACH: Atlanta Micro, Inc. neither uses nor intentionally adds any of the substances considered to be a Substance of Very High Concern (SVHC) as defined by the EU Regulation (EC) No. 1907-2006 on Registration, Evaluation, Authorization, and Restriction of Chemicals (REACH).

Conflict Materials: Atlanta Micro does not knowingly use materials that are sourced from the Democratic Republic of Congo (DRC) or any other known conflict regions. Atlanta Micro’s supply chain is comprised of sources that are both environmentally and socially responsible. We periodically review this requirement with our vendors to ensure continued compliance.

Atlanta Micro takes its responsibility as a global partner seriously and will use due diligence within our supply chain to ensure all standards are met to the best of our knowledge.