

Model 7891

Programmable multifrequency clock synthesizer PCIe board

Ideal for A/D and D/A converter clock sources

- Simultaneous synthesis of up to five different clocks
- Eight SMC clock outputs
- Typical phase noise: -105 dBc/Hz @ 1 kHz offset
- All clocks are phase-locked to input reference signal

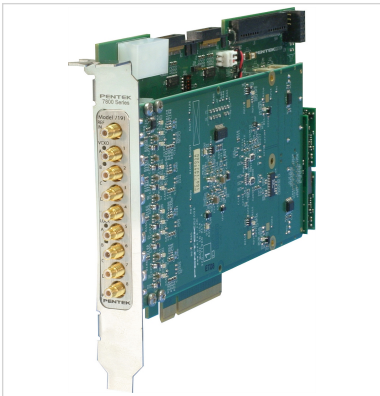

The Model 7891 generates up to eight synthesized clock signals suitable for driving A/D and D/A converters in high-performance real-time data acquisition and software radio systems. The clocks offer exceptionally low phase noise and jitter to preserve the signal quality of the data converters. These clocks are synthesized from on-board quad VCXOs (voltage controlled oscillators) and can be phase-locked to an external reference signal.

FEATURES

- Input reference frequency of 5 to 100 MHz
- Four programmable VCXOs with 32-bit tuning resolution
- Output clocks of 1, 2, 4, 8, or 16 submultiples of VCXO base frequencies
- Output clock frequencies between 50 and 700 MHz
- Control and status via PCIe bus interface

BLOCK DIAGRAM

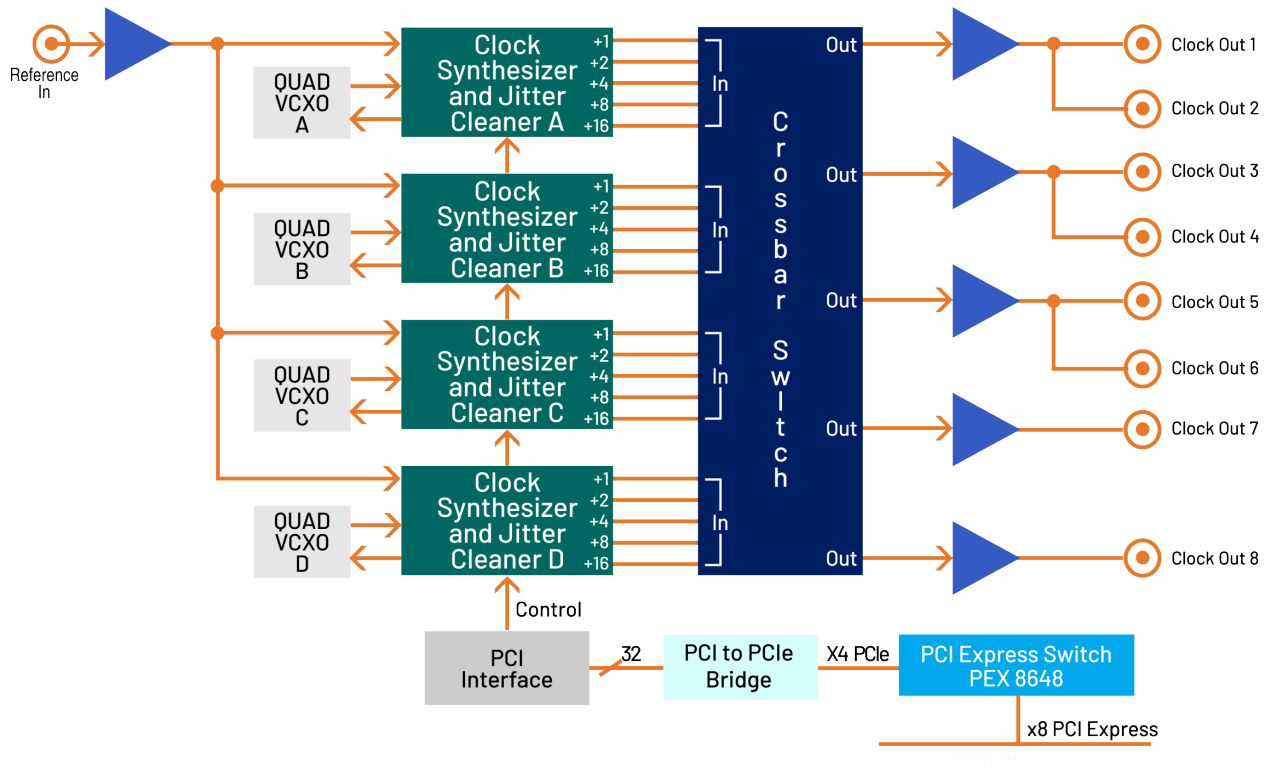

CLOCK SYNTHESIZER CIRCUITS

The 7891 uses four Texas Instruments CDC7005 clock synthesizer and jitter cleaner devices. Each CDC7005 is paired with a dedicated VCXO to provide the base frequency for the clock synthesizer. Each of the four VCXOs can be independently programmed to generate one of four frequencies between 50 and 700 MHz with a 32-bit tuning resolution.

The CDC7005 can output the programmed frequency of its associated VCXO, or generate submultiples using divisors of 2, 4, 8 or 16. The four CDC7005's can output up to five frequencies each. The 7891 can be programmed to route any of these 20 frequencies to the board's five output drivers.

The CDC7005 includes phase-locking circuitry that locks the frequency of its associated VCXO to an input reference clock. This reference is a 5 to 100 MHz signal supplied to a front panel SMC connector.

Eight front panel SMC connectors supply synthesized clock outputs driven from the five clock output drivers, as shown in the block diagram. This supports a single identical clock to all eight outputs or up to five different clocks to various outputs.

With four independently programmable VCXOs and each CDC7005 capable of providing up to five different submultiple clocks, a wide range of clock configurations is possible. In systems where more than five different clock outputs are required simultaneously, multiple 7891's can be used and phase-locked with a 5 to 100 MHz system reference.

PCI EXPRESS INTERFACE

The Model 7891 includes a multiple port, 48-lane Gen. 2 PCIe switch with integrated SerDes. The switch provides

x8 wide connection to the PCIe interface.

FRONT PANEL CONNECTIONS

The front panel includes one SMC connector for a reference signal input, eight SMC connectors for clock outputs and ten LED indicators. Please use the cables described in Ordering Information.

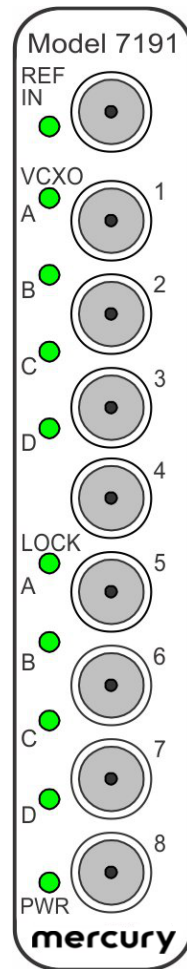

- **Reference Input Connector:** One SMC receptacle, labeled **REF IN**, for input of an external reference clock.
- **Clock Output Connectors:** Eight SMC connectors for the Clock signal inputs labeled **CLK 1 - 8**. The clock output signal is within the range of +4 dBm. This output is driven into 50 Ω output impedance.
- **REF IN LED:** A green LED labeled **REF IN** illuminates when a reference clock input is applied to the board.
- **VCXO LEDs:** Four green LEDs

labeled **VCXO A-D** illuminate when the associated VCXO input is valid (A is for VCXO 1, B for VCXO 2, C for VCXO 3, D for VCXO 4).

- **Lock LEDs:** Four green LEDs labeled **LOCK A-D** illuminate when the associated VCXO PLL is locked (A is

for VCXO 1, B for VCXO 2, C for VCXO 3, D for VCXO 4).

- **Power LED:** A green LED labeled **PWR** illuminates when a +5VDC is applied to the board.

SPECIFICATIONS

Front Panel Reference Input

Connector Type: SMC
 Input Impedance: 50 ohms
 Reference Frequency: 5 to 100 MHz
 Input Level: -6 dBm to +10 dBm

PLL Clock Synthesizers & Jitter Cleaner

Quantity: 4
 Type: Texas Instruments CDC7005
 Frequency Dividers: 1, 2, 4, 8 and 16

Programmable VXCOS (Quantity: 4)

Frequency Range: 50 to 700 MHz
 Tuning Resolution: 32 bits
 Unlocked Accuracy: ±20 ppm

Front Panel Clock Outputs (Quantity: 8)

Connector Type: SMC
 Output Impedance: 50 ohms
 Output Level: +3 dBm @ 700 MHz
 Typ. Phase Noise: -105 dBc/Hz @ 1 kHz (dependent on reference source stability)

PCI to PCIe Interface

PCIe Interface: Gen. 2, x8 width
 PCIe Ports: one x4 port to PCI bus, one x8 port to PCIe motherboard
 Operation: control and status interface

Environmental

- Operating Temp: 0° to 50° C
- Storage Temp: -20° to 90° C
- Relative Humidity: 0 to 95%, non-cond.

Size

Half-length PCIe, 4.38 in. x 6.6 in.

ORDERING INFORMATION

Model	Description
7891*	Programmable Multifrequency Clock Synthesizer - Half-length x8 PCIe

*Specify frequencies of factory-installed programmable VCXOs between 50 and 700 MHz. Contact techsales@mrct.com to order specific frequencies.

ACCESSORY PRODUCTS

Model	Description
2891	Timing bus cables

LIFETIME SUPPORT

Mercury offers worldwide customers shorter development time, reliable, rugged solutions for a variety of environments, reduced costs, and mature software development tools. We offer free lifetime support for this product from our engineering staff, which customers can depend on through phone and email, as well as software updates. Take advantage of our 40 years of experience in delivering high-performance radar, communications, SIGINT, EW, and data acquisition MIL-Aero solutions worldwide.



Corporate Headquarters

50 Minuteman Road
 Andover, MA 01810 USA
+1 978.967.1401 tel
+1 866.627.6951 tel
+1 978.256.3599 fax

International Headquarters

Mercury International
 Avenue Eugène-Lance, 38
 PO Box 584
 CH-1212 Grand-Lancy 1
 Geneva, Switzerland
+41 22 884 5100 tel

Learn more

Visit: mrct.com/go/MP7891

For technical details, contact:
mrct.com/go/CF7891



The Mercury Systems logo and the following are trademarks or registered trademarks of Mercury Systems, Inc.: Mercury Systems, Innovation That Matters, Flexor, Jade, Cobalt, Onyx, GateFlow, ReadyFlow, and Navigator. Other marks used herein may be trademarks or registered trademarks of their respective holders. Mercury believes this information is accurate as of its publication date and is not responsible for any inadvertent errors. The information contained herein is subject to change without notice.

