

AM6012 – Switch



DC to 18 GHz SPDT

Description

AM6012 is a Single-Pole Double-Throw (SPDT) switch covering the DC to 18 GHz frequency range. The positive control device exhibits low insertion loss, flat frequency response and high isolation over the operating temperature range of -40C to +85C.

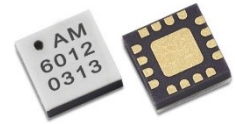

Features

- 1.0 dB Insertion Loss
- +45 dBm Input IP3
- +3.3V to +5V Supply
- +3.3V to +5V Control
- >25 dB Isolation
- 3mm QFN
- -40C to +85C Operation

Functional Diagram

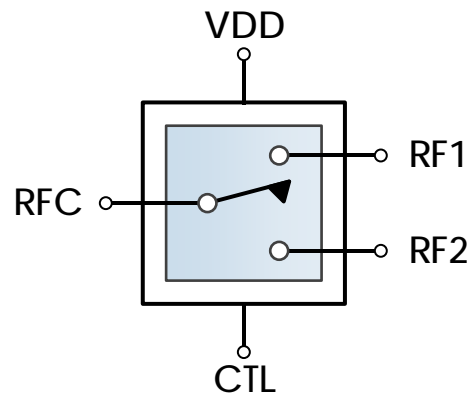

Characteristic Performance

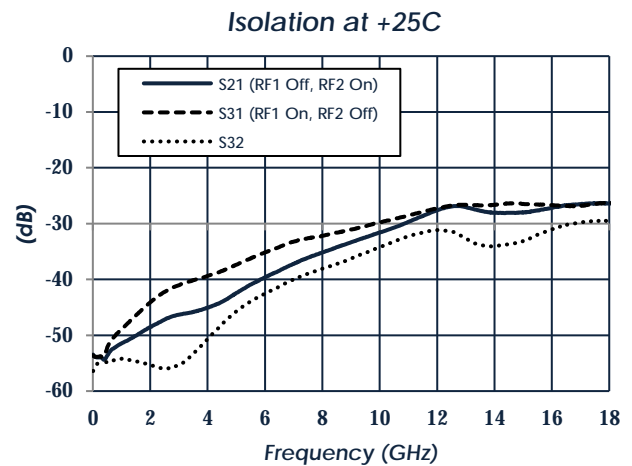
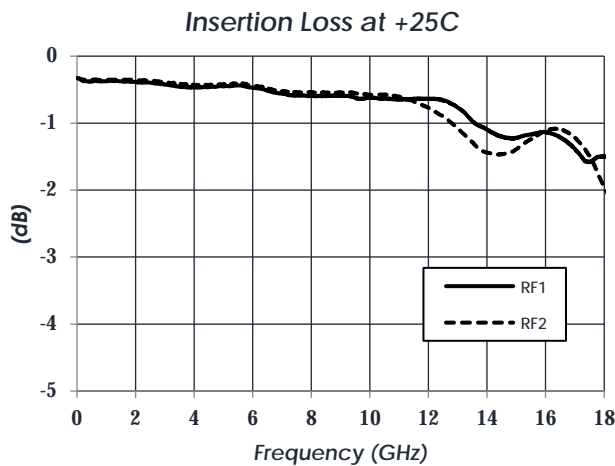

Table of Contents

Description	1	DC Electrical Characteristics.....	5
Features.....	1	RF Performance.....	5
Functional Diagram.....	1	Timing Characteristics	5
Characteristic Performance	1	State Table.....	5
Revision History	2	Typical Performance	6
Pin Layout and Definitions.....	3	Typical Application.....	7
Specifications	4	Package Details.....	8
Absolute Maximum Ratings.....	4	Evaluation PC Board	9
Handling Information.....	4	Related Parts.....	9
Recommended Operating Conditions ...	4	Component Compliance Information.....	10

Revision History

Date	Revision Number	Notes
September 10, 2018	1	Initial Release

Pin Layout and Definitions

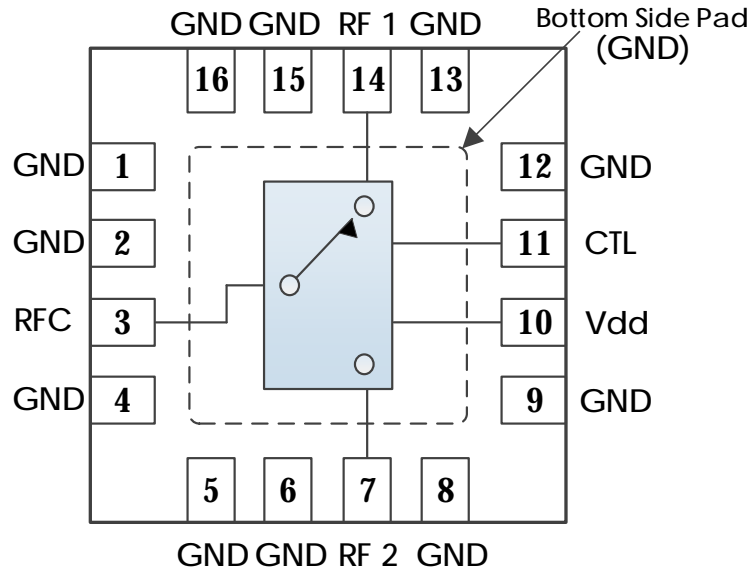

Pin Number	Pin Name	Pin Function
1,2	GND	Ground – Common
3	RFC	RFC Input – 50 ohms – DC Coupled. External DC blocking capacitor required*
4-6	GND	Ground – Common
7	RF2	RF2 Output – 50 ohms – DC Coupled. External DC blocking capacitor required*
8,9	GND	Ground – Common
10	VDD	DC Power Input
11	CTL	Switch Control
12,13	GND	Ground – Common
14	RF1	RF1 Output – 50 ohms – DC Coupled. External DC blocking capacitor required*
15,16	GND	Ground – Common
Case GND	GND	Ground – Common

*Note: DC blocking capacitors not required if in series with other Atlanta Micro parts of the same reference voltage.

AM6012 – Switch



DC to 18 GHz SPDT

Specifications

Absolute Maximum Ratings

	Minimum	Maximum
Supply Voltage	-0.3 V	+6.0 V
RF Input Power		+27 dBm
Operating Junction Temperature	-40 C	+150 C
Storage Temperature Range	-50 C	+150 C

Note: Any device operation beyond the Absolute Maximum Ratings may result in permanent damage to the device. The values listed in this table are extremes and do not imply functional operation of the device at these or any other conditions beyond what is listed under Recommended Operating Conditions. Any part subjected to conditions outside of what is recommended for an extended amount of time may suffer from reliability concerns.

Handling Information

	Minimum	Maximum
Storage Temperature Range (Recommended)	-50 C	+125 C
Moisture Sensitivity Level	MSL 1	



Atlanta Micro products are electrostatic sensitive.
Follow safe handling practices to avoid damage

Recommended Operating Conditions

	Minimum	Typical	Maximum
Supply Voltage	+2.25 V	+5.0 V	
Operating Case Temperature	-40 C		+85 C
Operating Junction Temperature	-40 C		+125 C

AM6012 – Switch

DC to 18 GHz SPDT

DC Electrical Characteristics

(T = 25 °C unless otherwise specified)

Parameter	Testing Conditions	Minimum	Typical	Maximum
DC Supply Voltage		+2.5 V	+5.0 V	
DC Supply Current	VDD = +3.3 V		<1 mA	
	VDD = +5.0 V		1mA	
Power Dissipated	VDD = +3.3 V		< 3.3 mW	
	VDD = +5.0 V		5.0 mW	
Logic Level Low		0.0 V		+0.5 V
Logic Level High		+2.0 V		+ VDD

RF Performance

(T = 25 °C unless otherwise specified)

Parameter	Testing Conditions	Minimum	Typical	Maximum
Frequency Range		DC		18 GHz
Insertion Loss	f = 10 MHz		0.3 dB	
	f = 9 GHz		0.6 dB	
	f = 18 GHz		1.5 dB	
Return Loss	f = 10 MHz		28.5 dB	
	f = 9 GHz		31.5 dB	
	f = 18 GHz		9.3 dB	
Input IP3	VDD = +5.0 V		+45 dBm	

Timing Characteristics

Parameter	Minimum	Typical	Maximum
Switching Speed (Path Enabled → Disabled)		650 ns	
Switching Speed (Path Disabled → Enabled)		700 ns	

State Table

CTL	State
Low	RFC to RF1
High	RFC to RF2

AM6012 – Switch



DC to 18 GHz SPDT

Typical Performance

(T = 25 °C, VDD = +5.0 V unless otherwise specified)

Insertion Loss vs Temperature

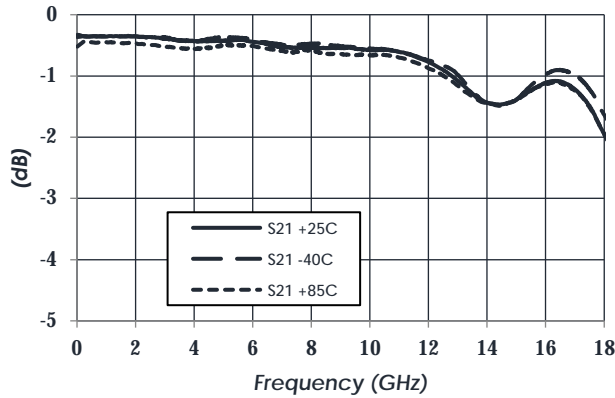

Isolation at +25C

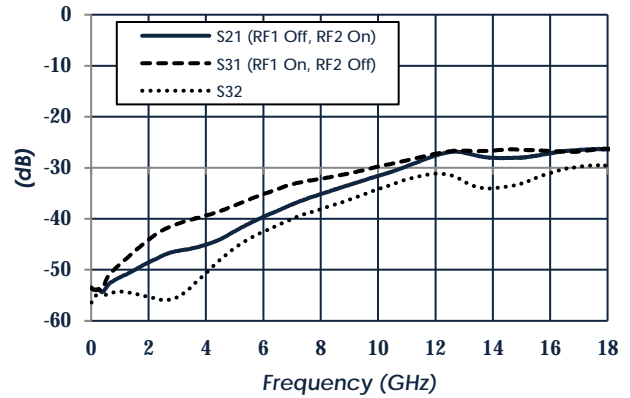

Return Loss at +25C

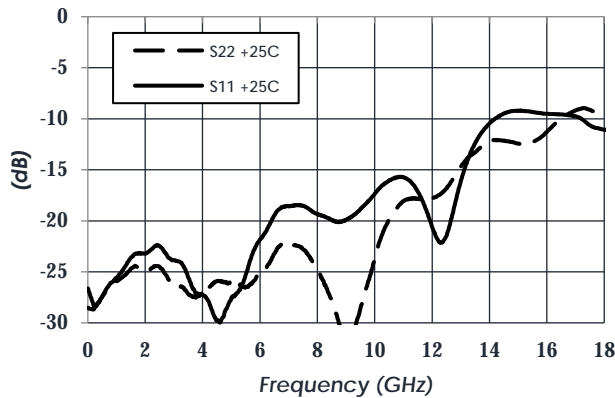

Input IP3 at +25C

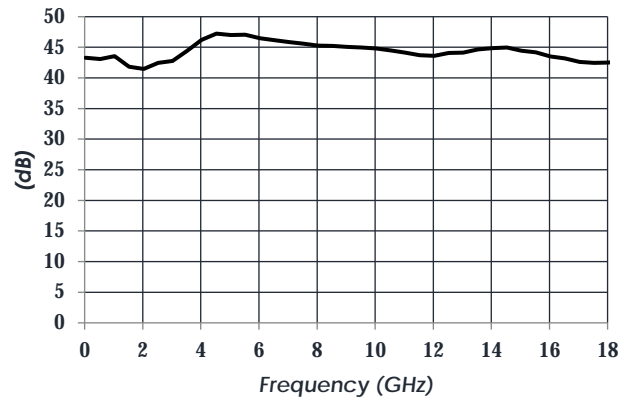

Input IP3 at +25 C

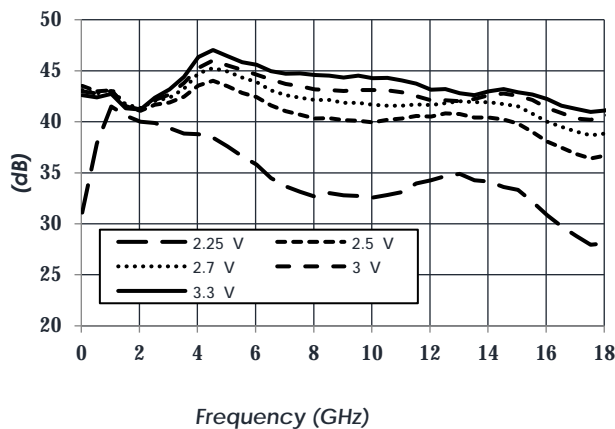

Input IP3 at +25 C

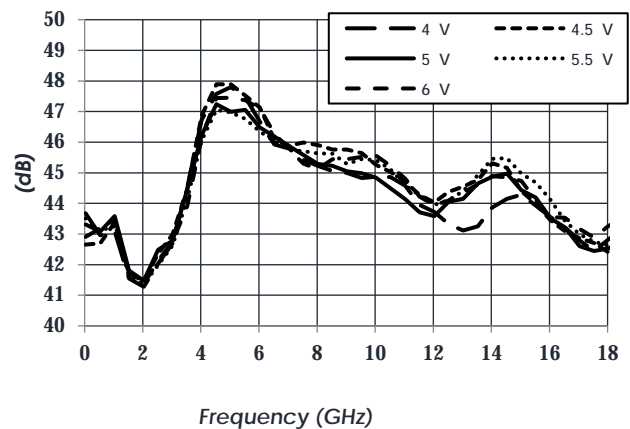

To obtain price, delivery, or to place an order contact MMICSales@mrcty.com
 Atlanta Micro Inc., 3720 Davinci Ct, Suite 125, Norcross, GA 30092 • Phone: (470) 253-7640 • www.atlantamicro.com

Typical Application

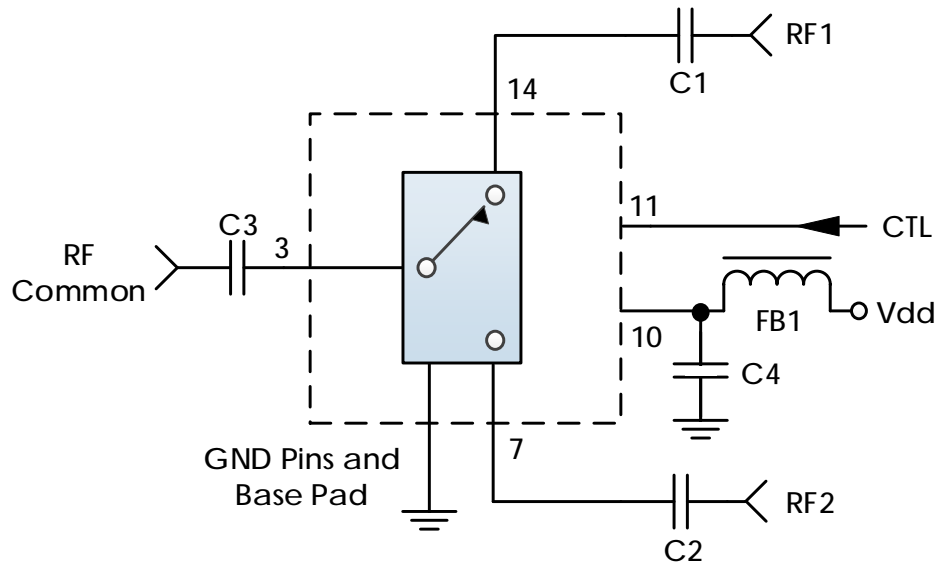

Recommended Component List (or equivalent):

Part	Value	Part Number	Manufacturer
C1 – C3	0.1 μ F	0201BB104KW160	Passives Plus
C4	0.1 μ F	C1005X7R1H104K050BB	TDK
FB1	-	MMZ1005A222E	TDK

Notes:

1. RF blocking capacitors should be high performance, low-loss, broadband capacitors for optimum performance.
2. RC filtering on the control line is recommended to prevent digital noise from coupling to the RF path
 - a. Select control line RC filter values based on desired logic source decoupling and switching speed.

Package Details

Package Drawing

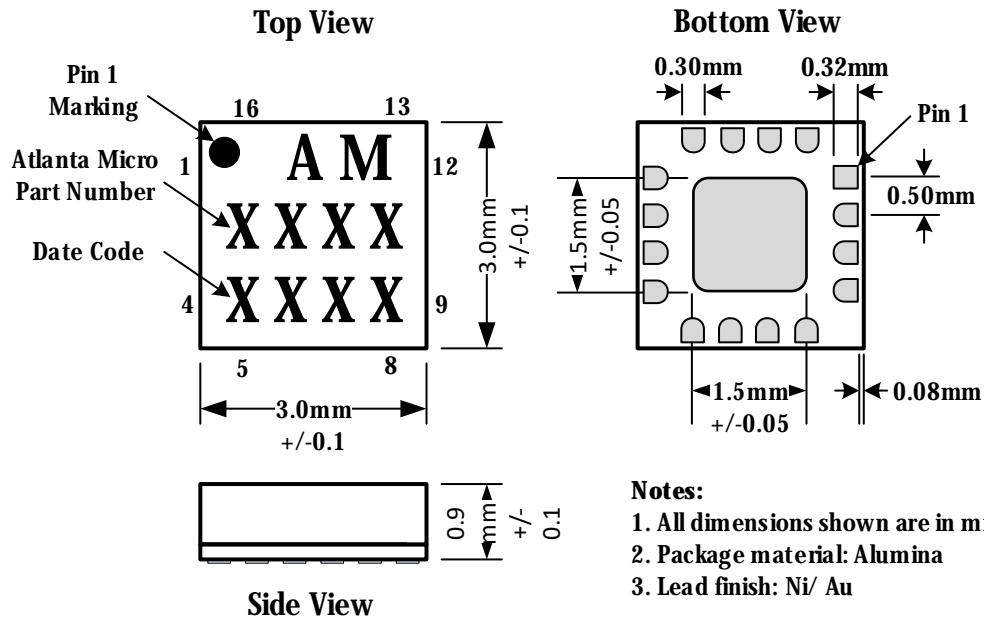

Recommended Footprint

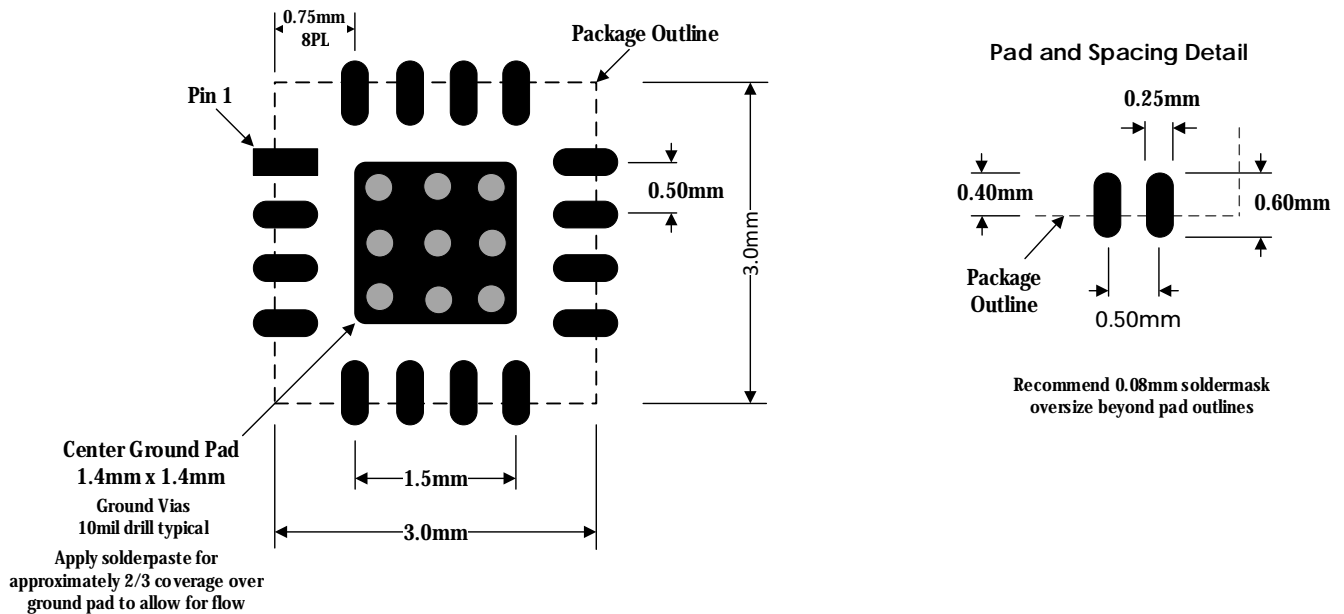

AM6012 – Switch

DC to 18 GHz SPDT

Evaluation PC Board

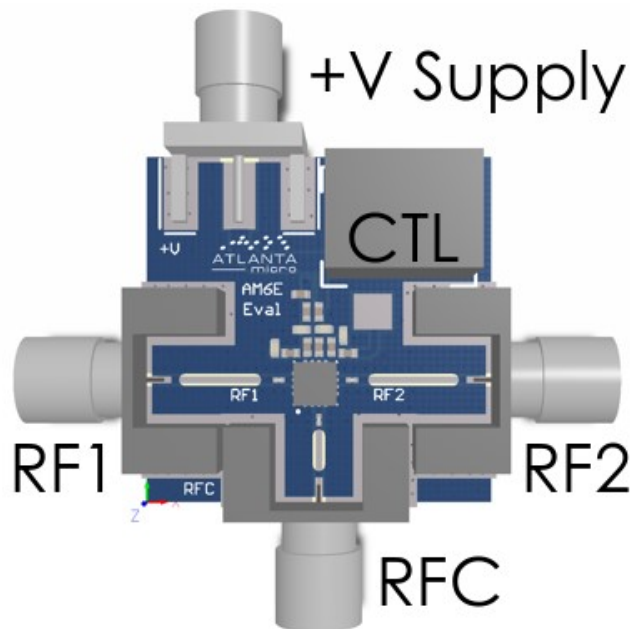

Related Parts

Part Number	Description
AM6002A	DC to 14 GHz SPDT
AM6011	DC to 10 GHz SP8T, Reflective
AM6015	DC to 18 GHz SP6T

Component Compliance Information

RoHS: Atlanta Micro, Inc. hereby certifies that all products comply with the EC Directive 2011/65/EC on the Restriction of Hazardous Substances, commonly known as RoHS II. All products supplied by Atlanta Micro shall be compliant with the European Directive 2011/65/EC based on the following substance list.

Substance List	Allowable Maximum Concentration
Lead (Pb)	<1000 PPM (0.1% by weight)
Mercury (Hg)	<1000 PPM (0.1% by weight)
Cadmium (Cd)	<75 PPM (0.0075% by weight)
Hexavalent Chromium (CrVI)	<1000 PPM (0.1% by weight)
Polybrominated Biphenyls (PBB)	<1000 PPM (0.1% by weight)
Polybrominated Diphenyl ethers (PBDE)	<1000 PPM (0.1% by weight)
Decabromodiphenyl Deca BDE	<1000 PPM (0.1% by weight)

REACH: Atlanta Micro, Inc. neither uses nor intentionally adds any of the substances considered to be a Substance of Very High Concern (SVHC) as defined by the EU Regulation (EC) No. 1907-2006 on Registration, Evaluation, Authorization, and Restriction of Chemicals (REACH).

Conflict Materials: Atlanta Micro does not knowingly use materials that are sourced from the Democratic Republic of Congo (DRC) or any other known conflict regions. Atlanta Micro’s supply chain is comprised of sources that are both environmentally and socially responsible. We periodically review this requirement with our vendors to ensure continued compliance.

Atlanta Micro takes its responsibility as a global partner seriously and will use due diligence within our supply chain to ensure all standards are met to the best of our knowledge.