

AM6042 – Switch

DC to 20 GHz, SP4T, Absorptive

Description

AM6042 is an absorptive Single-Pole Four-Throw (SP4T) switch covering the DC to 20 GHz frequency range suited for a wide range of wireless applications. The AM6042 provides low insertion loss, flat frequency response, high isolation and linearity, and fast switching speed making this switch ideal for high frequency, low power transmit/receive applications. The AM6042 requires only a single positive supply and two positive control voltages. With internal 50Ω matching, internal decoder circuitry, and low current draw all packaged in a 4mm QFN, the AM6042 represents a compact total PCB footprint with minimal size, weight, and power (low SWaP).



Features

- 1.8 dB Insertion Loss
- +38 dBm Input IP3
- +3.3V to +5.0V Supply
- +3.3V to +5.0V Control
- >40 dB Isolation
- 3mm QFN
- -40C to +85C Operation

Functional Diagram

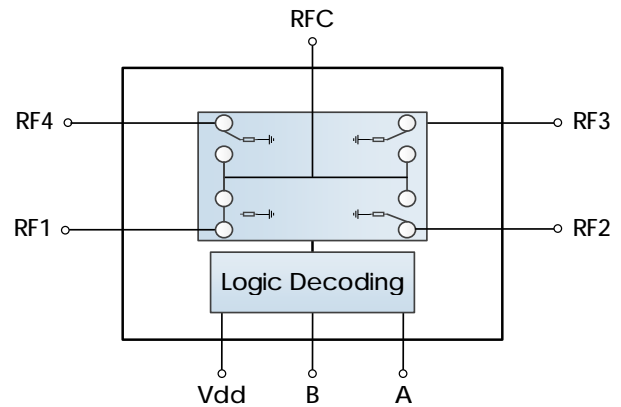

Characteristic Performance

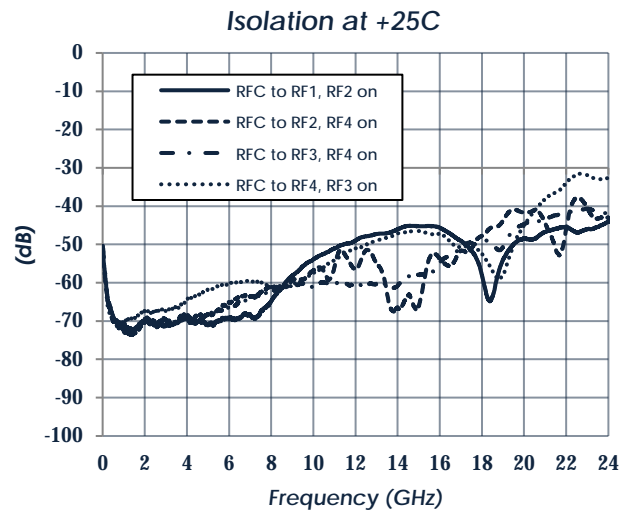
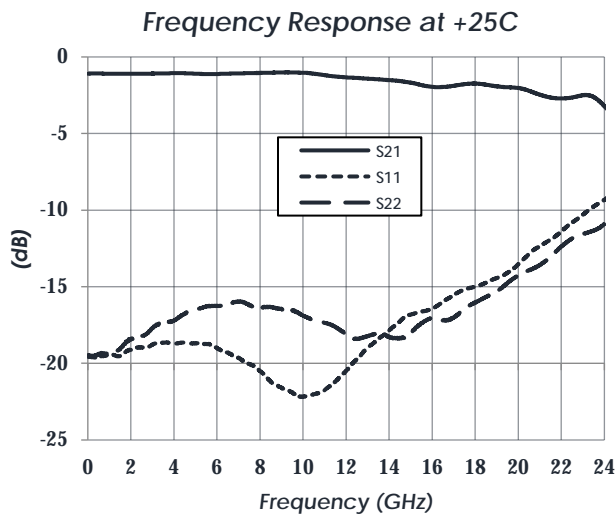

To obtain price, delivery, or to place an order contact MMICSales@mrchy.com
 Atlanta Micro Inc., Now a part of Mercury Systems
 3720 Davinci Ct, Suite 400, Peachtree Corners, GA 30092 • Phone: (470) 253-7640 • www.atlantamicro.com

Table of Contents

Description	1	RF Performance	6
Features	1	Timing Characteristics	6
Functional Diagram	1	State Table	6
Characteristic Performance	1	Typical Performance	7
Revision History	2	Typical Performance Continued	8
Pin Layout and Definitions	3	Typical Performance Continued 2	9
Specifications	5	Typical Applications	10
Absolute Maximum Ratings	5	Evaluation PC Board	11
Handling Information	5	Related Parts	11
Recommended Operating Conditions	5	Component Compliance Information	12
DC Electrical Characteristics	6		

Revision History

Date	Revision Number	Notes
January 26, 2022	1	Initial Release
May 18, 2022	2	Added Switching Speed and Corrected Initial Release Date
August 16, 2022	3	Fixed Logic Table

AM6042 – Switch



DC to 20 GHz, SP4T, Absorptive

Pin Layout and Definitions

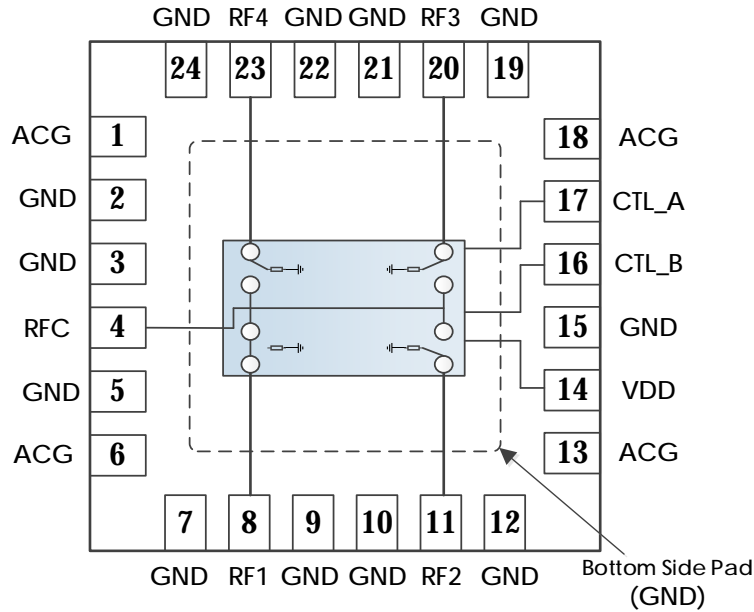

Pin Number	Pin Name	Pin Function
1	ACG	Optional AC Ground **
2,3	GND	Ground - Common
4	RFC	RF Input - 50 Ohms - DC Coupled. External DC blocking capacitor required*
5	GND	Ground - Common
6	ACG	Optional AC Ground **
7	GND	Ground - Common
8	RF1	RF Output - 50 Ohms - DC Coupled. External DC blocking capacitor required*
9, 10	GND	Ground - Common
11	RF2	RF Output - 50 Ohms - DC Coupled. External DC blocking capacitor required*
12	GND	Ground - Common
13	ACG	Optional AC Ground **
14	VDD	DC Power Input
15	GND	Ground - Common
16	CTL_B	Switch Control B
17	CTL_A	Switch Control A
18	ACG	Optional AC Ground **
19	GND	Ground - Common
20	RF3	RF Output - 50 Ohms - DC Coupled. External DC blocking capacitor required*
21, 22	GND	Ground - Common

To obtain price, delivery, or to place an order contact MMICSales@mrchy.com
 Atlanta Micro Inc., Now a part of Mercury Systems
 3720 Davinci Ct, Suite 400, Peachtree Corners, GA 30092 • Phone: (470) 253-7640 • www.atlantamicro.com

AM6042 – Switch

DC to 20 GHz, SP4T, Absorptive

23	RF4	RF Output – 50 Ohms – DC Coupled. External DC blocking capacitor required*
24	GND	Ground - Common

Notes:

* DC Blocking caps not required if in series with other Atlanta Micro parts of the same reference voltage

** AC Ground caps optional. Installing AC ground capacitors offer optimum absorptive performance below 400 MHz. See *Typical Performance* section for more details.

AM6042 – Switch



DC to 20 GHz, SP4T, Absorptive

Specifications

Absolute Maximum Ratings

	Minimum	Maximum
Supply Voltage	-0.3 V	+6.0 V
RF Input Power		+27 dBm
Storage Temperature Range	-55 C	+150 C

Note: Any device operation beyond the Absolute Maximum Ratings may result in permanent damage to the device. The values listed in this table are extremes and do not imply functional operation of the device at these or any other conditions beyond what is listed under Recommended Operating Conditions. Any part subjected to conditions outside of what is recommended for an extended amount of time may suffer from reliability concerns.

Handling Information

	Minimum	Maximum
Moisture Sensitivity Level	MSL 3	



Atlanta Micro products are electrostatic sensitive.
Follow safe handling practices to avoid damage

Recommended Operating Conditions

	Minimum	Typical	Maximum
Supply Voltage	+2.5 V	+5.0 V	
Operating Case Temperature	-40 C		+85 C

To obtain price, delivery, or to place an order contact MMICSales@mercy.com
Atlanta Micro Inc., Now a part of Mercury Systems
3720 Davinci Ct, Suite 400, Peachtree Corners, GA 30092 • Phone: (470) 253-7640 • www.atlantamicro.com

AM6042 – Switch

DC to 20 GHz, SP4T, Absorptive

DC Electrical Characteristics

(T = 25 °C unless otherwise specified)

Parameter	Testing Conditions	Minimum	Typical	Maximum
DC Supply Voltage		+2.7 V	+5.0 V	
DC Supply Current	VDD = +3.3 V		5 mA	
	VDD = +5.0 V		5 mA	
Power Dissipated	VDD = +3.3 V		16.5 mW	
	VDD = +5.0 V		25 mW	
Logic Level Low		0.0 V		+0.5 V
Logic Level High		+2.0 V		+VDD

RF Performance

(T = 25 °C unless otherwise specified)

Parameter	Testing Conditions	Minimum	Typical	Maximum
Frequency Range		DC		20 GHz
Insertion Loss	f = 0.01 GHz		1 dB	
	f = 10 GHz		1.5 dB	
	f = 20 GHz		2.5 dB	
Return Loss	f = 0.01 GHz		20 dB	
	f = 10 GHz		20 dB	
	f = 20 GHz		17 dB	
Input IP3	VDD = +5.0V		+38 dBm	
Isolation	VDD = +5.0V		+45 dBm	

Timing Characteristics

Parameter	Minimum	Typical	Maximum
Switching Speed (Path Enabled to Disabled)		15 ns	
Switching Speed (Path Disabled to Enabled)		15 ns	

State Table

CTL A	CTL B	State
Low	Low	RFC to RF1
Low	High	RFC to RF3
High	Low	RFC to RF2
High	High	RFC to RF4

To obtain price, delivery, or to place an order contact MMICSales@rcy.com
 Atlanta Micro Inc., Now a part of Mercury Systems
 3720 Davinci Ct, Suite 400, Peachtree Corners, GA 30092 • Phone: (470) 253-7640 • www.atlantamicro.com

AM6042 – Switch

DC to 20 GHz, SP4T, Absorptive

Typical Performance

(VDD = +5.0 V, T = 25 °C. Data measured via probes outside IC package on 10 mil Rogers RO4350B™)

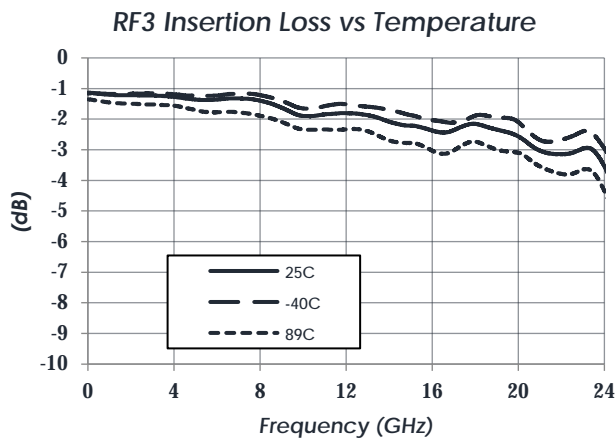
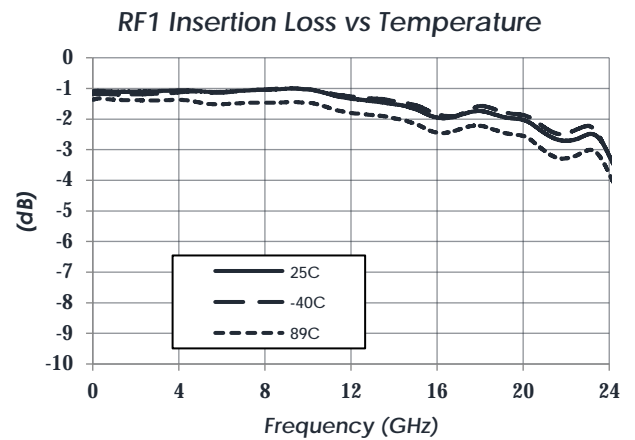
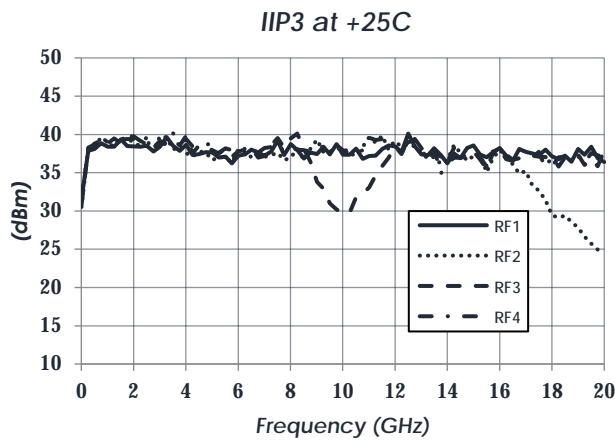
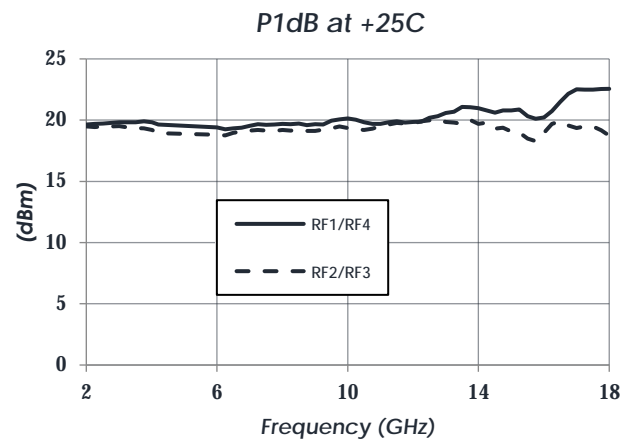
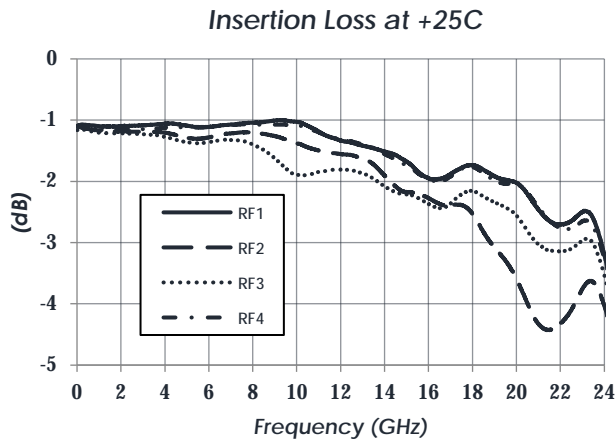

To obtain price, delivery, or to place an order contact MMICSales@mrchy.com
 Atlanta Micro Inc., Now a part of Mercury Systems
 3720 Davinci Ct, Suite 400, Peachtree Corners, GA 30092 • Phone: (470) 253-7640 • www.atlantamicro.com

AM6042 – Switch

DC to 20 GHz, SP4T, Absorptive

Typical Performance Continued

(VDD = +5.0 V, T = 25 °C. Data measured via probes outside IC package on 10 mil Rogers RO4350B™)

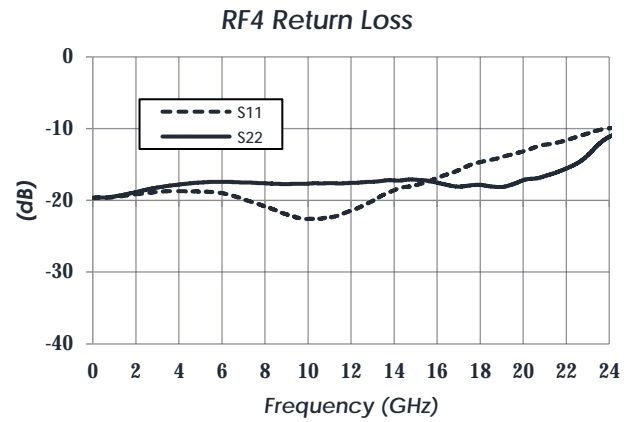
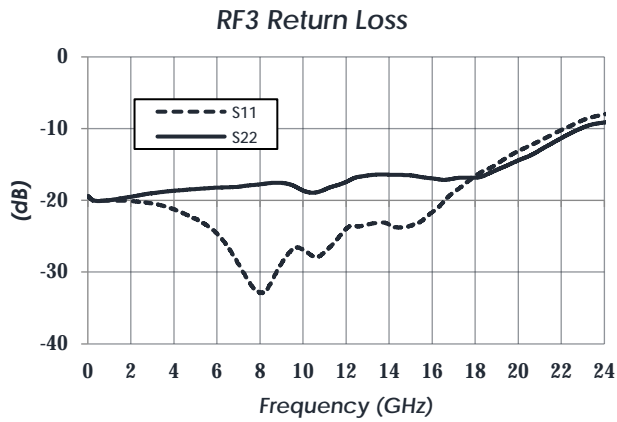
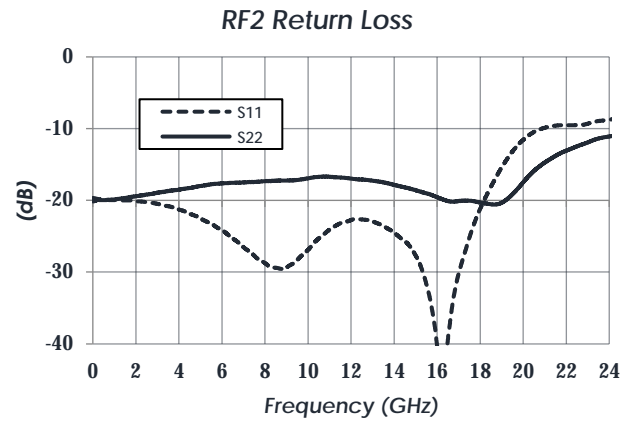
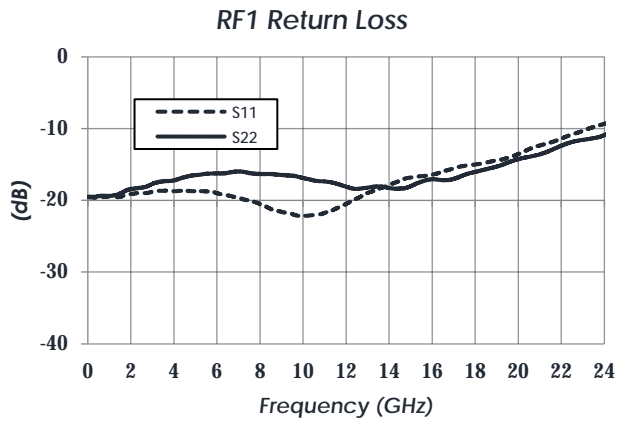

To obtain price, delivery, or to place an order contact MMICSales@mercy.com
 Atlanta Micro Inc., Now a part of Mercury Systems
 3720 Davinci Ct, Suite 400, Peachtree Corners, GA 30092 • Phone: (470) 253-7640 • www.atlantamicro.com

AM6042 – Switch

DC to 20 GHz, SP4T, Absorptive

Typical Performance Continued 2

(VDD = +5.0 V, T = 25 °C. Data measured via probes outside IC package on 10 mil Rogers RO4350B™)

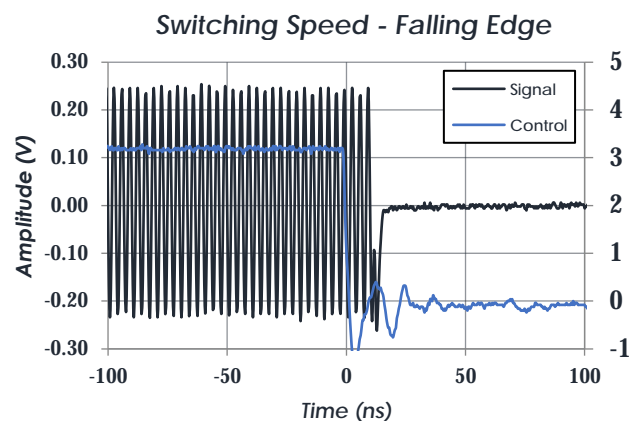
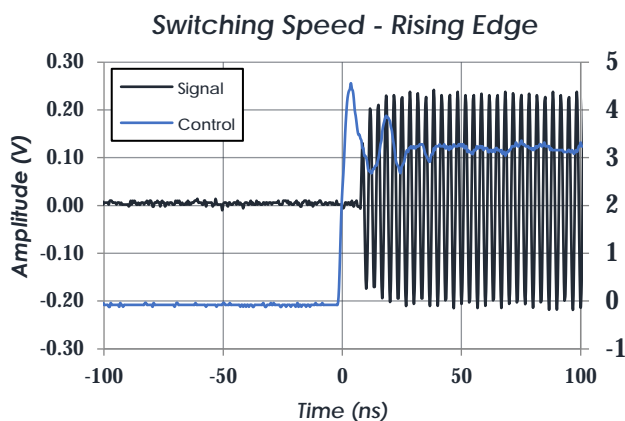
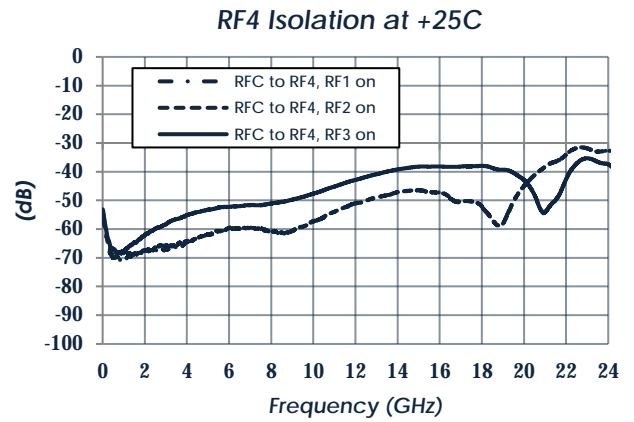
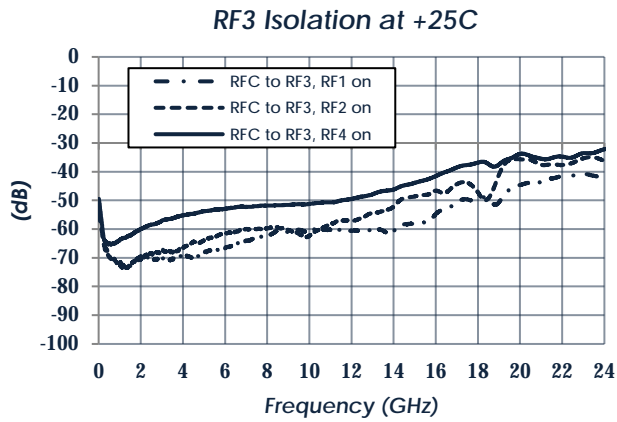
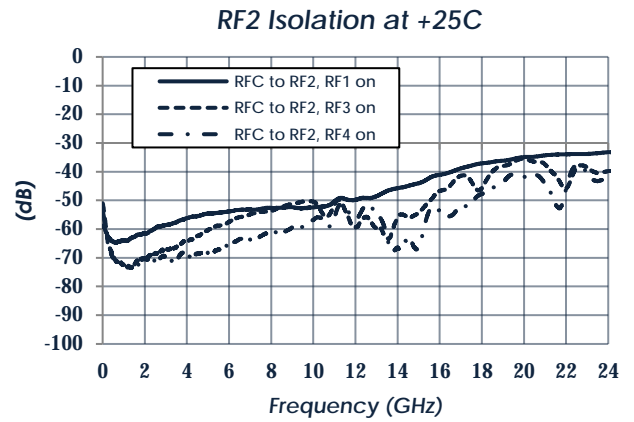
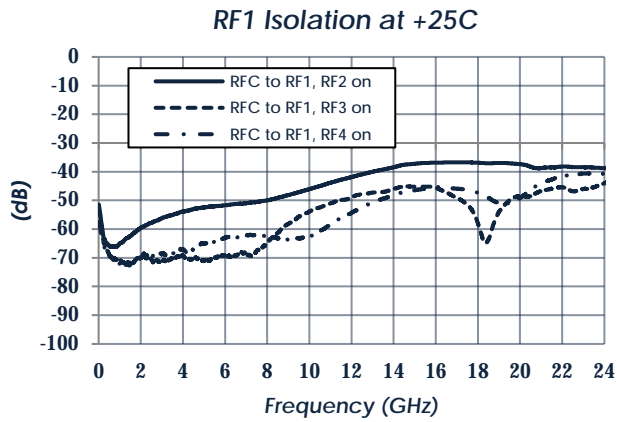

To obtain price, delivery, or to place an order contact MMICSales@mercy.com
 Atlanta Micro Inc., Now a part of Mercury Systems
 3720 Davinci Ct, Suite 400, Peachtree Corners, GA 30092 • Phone: (470) 253-7640 • www.atlantamicro.com

AM6042 – Switch



DC to 20 GHz, SP4T, Absorptive

Typical Applications

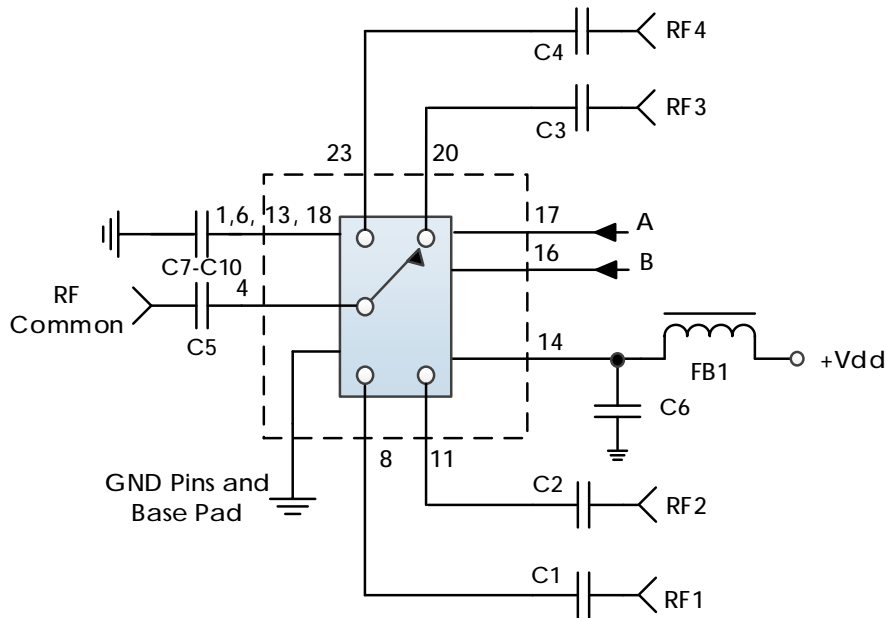

Recommended Component List (or equivalent):

Part	Value	Part Number	Manufacturer
C1-C5	0.1 μ F	0201BB104KW160	Passives Plus
C6-C10	0.1 μ F	C1005X7R1H104K050BB	TDK
FB1	-	MMZ1005A222E	TDK

Notes:

1. DC blocking capacitors should be high performance, low-loss, broadband capacitors for optimal performance.
2. RC Filtering on the control line is recommended to prevent digital noise from coupling to the RF path.
 - a. Select control line RC filter values based on desired logic source decoupling and switching speed.
3. Installing capacitors C7-C10 is recommended for absorptive performance below 400 MHz.

To obtain price, delivery, or to place an order contact MMICSales@mrchy.com
Atlanta Micro Inc., Now a part of Mercury Systems
3720 Davinci Ct, Suite 400, Peachtree Corners, GA 30092 • Phone: (470) 253-7640 • www.atlantamicro.com

AM6042 – Switch



DC to 20 GHz, SP4T, Absorptive

Evaluation PC Board

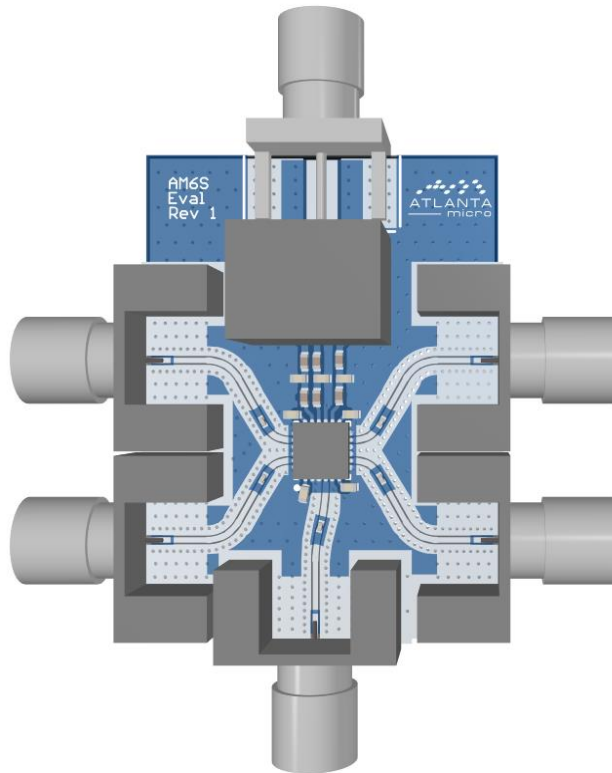

Related Parts

Part Number	Description
AM6012	DC to 18 GHz SPDT, Reflective
AM6013	DC to 18 GHz SP4T, Reflective
AM6015	DC to 18 GHz SP6T, Reflective
AM6016	DC to 26.5 GHz SPDT, Reflective
AM6017	DC to 26.5 GHz SP4T, Reflective
AM6029	DC to 18 GHz SP4T, Reflective
AM6031	DC to 20 GHz SPDT, Absorptive

To obtain price, delivery, or to place an order contact MMICSales@mrcy.com
Atlanta Micro Inc., Now a part of Mercury Systems
3720 Davinci Ct, Suite 400, Peachtree Corners, GA 30092 • Phone: (470) 253-7640 • www.atlantamicro.com

Component Compliance Information

RoHS: Atlanta Micro, Inc. hereby certifies that all products comply with the EC Directive 2011/65/EC on the Restriction of Hazardous Substances, commonly known as EU-RoHS 6 and 10. All products supplied by Atlanta Micro shall be compliant with the European Directive 2011/65/EC based on the following substance list.

Substance List	Allowable Maximum Concentration
Lead (Pb)	<1000 PPM (0.1% by weight)
Mercury (Hg)	<1000 PPM (0.1% by weight)
Cadmium (Cd)	<75 PPM (0.0075% by weight)
Hexavalent Chromium (CrVI)	<1000 PPM (0.1% by weight)
Polybrominated Biphenyls (PBB)	<1000 PPM (0.1% by weight)
Polybrominated Diphenyl ethers (PBDE)	<1000 PPM (0.1% by weight)
Decabromodiphenyl Deca BDE	<1000 PPM (0.1% by weight)
Bis (2-ethylhexyl) Phthalate (DEHP)	<1000 PPM (0.1% by weight)
Butyl Benzyl Phthalate (BBP)	<1000 PPM (0.1% by weight)
Dibutyl Phthalate (DBP)	<1000 PPM (0.1% by weight)
Diisobutyl Phthalate (DIBP)	<1000 PPM (0.1% by weight)

REACH: Atlanta Micro, Inc. neither uses nor intentionally adds any of the substances considered to be a Substance of Very High Concern (SVHC) as defined by the EU Regulation (EC) No. 1907-2006 on Registration, Evaluation, Authorization, and Restriction of Chemicals (REACH).

Conflict Materials: Atlanta Micro does not knowingly use materials that are sourced from the Democratic Republic of Congo (DRC) or any other known conflict regions. Atlanta Micro’s supply chain is comprised of sources that are both environmentally and socially responsible. We periodically review this requirement with our vendors to ensure continued compliance.

Atlanta Micro takes its responsibility as a global partner seriously and will use due diligence within our supply chain to ensure all standards are met to the best of our knowledge.