

# AM3129 – Filter Bank

## Analog Tunable 1.0 to 6.0 GHz Notch

### Description

AM3129 is an analog voltage-tunable notch filter bank with notches from 1.0 to 6.0 GHz. Six notch filters and two bypass paths with SP8T switches on the input and output are contained in the multi-chip module (MCM). Two tune voltages are used to provide precise control of center frequency and notch bandwidth. AM3129 provides an excellent filtering solution for receiver or transceiver requiring flexible center frequency removal, high dynamic range, low insertion loss, and small size, weight, and power consumption (low SWAP).

### Features

- Analog Tuning
- 4 dB Typical Insertion Loss
- 30 dB Typical Notch Depth
- Two Bypass Paths, DC – 10 GHz
- +3.3V to +5V Supply
- +3V to +5V Control
- +0.0V to +7V Tuning Voltage Range
- 9mm QFN Package
- -40C to +85C Operation

### Functional Diagram

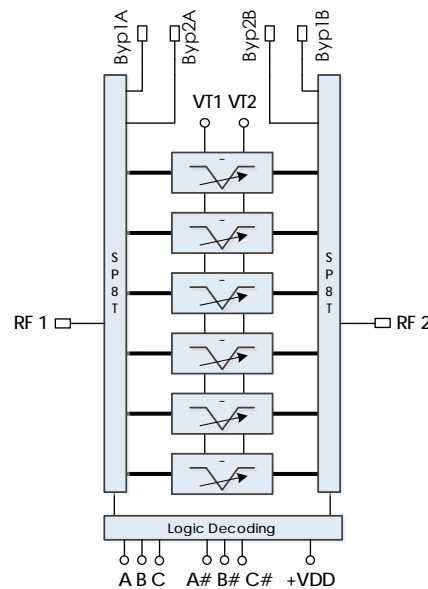

### Characteristic Performance

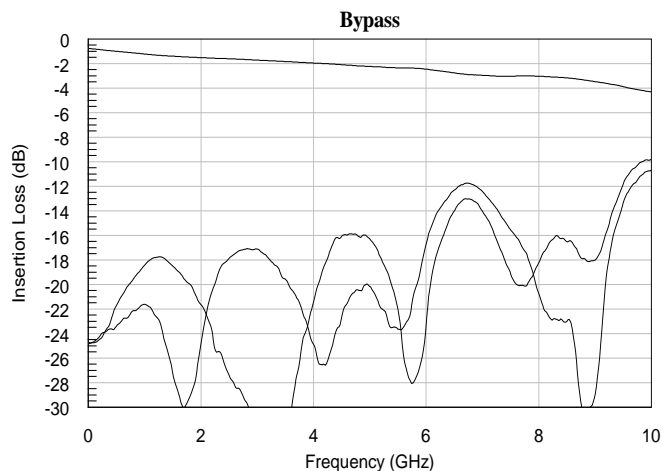
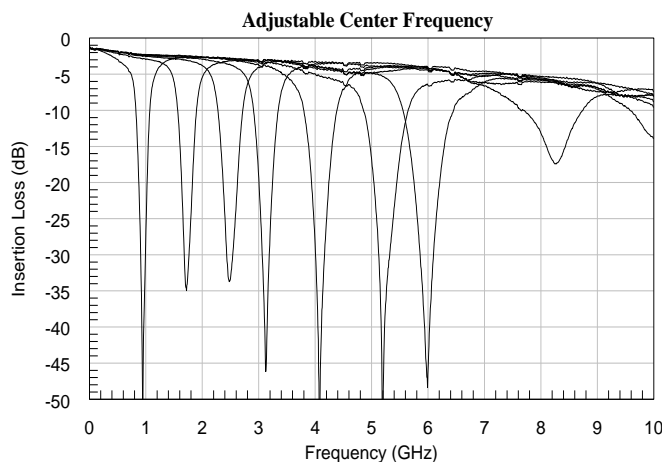

### Table of Contents

Description .....	1	RF Performance .....	5
Features .....	1	Timing Characteristics .....	5
Functional Diagram .....	1	State Table .....	5
Characteristic Performance .....	1	Typical Performance .....	6
Revision History .....	2	<b>Typical Applications .....</b>	<b>8</b>
Pin Layout and Definitions .....	3	Two Control Voltages .....	8
Specifications .....	4	Low Component Count .....	9
Absolute Maximum Ratings .....	4	Single Control Voltage .....	10
Handling Information .....	4	<b>Evaluation PC Board .....</b>	<b>11</b>
Recommended Operating Conditions .....	4	<b>Related Parts .....</b>	<b>11</b>
DC Electrical Characteristics .....	5	<b>Component Compliance Information .....</b>	<b>12</b>

### Revision History

Date	Revision Number	Notes
May 15, 2020	1	Initial Release
October 13, 2020	2	Filter notch locations clarified. Various diagrams clarified.

# AM3129 – Filter Bank



## Analog Tunable 1.0 to 6.0 GHz Notch

### Pin Layout and Definitions

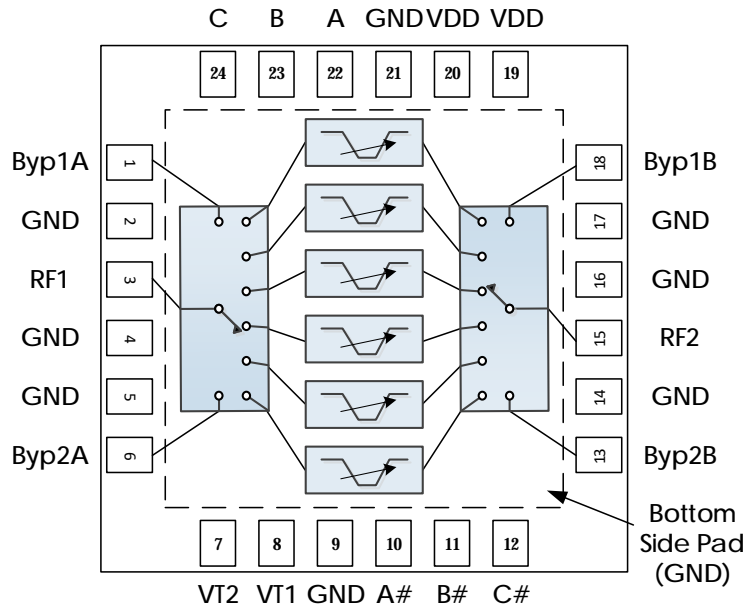

Pin Number	Pin Name	Pin Function
1	Byp1A	Optional DC to 10 GHz RF port – Pin 18 Return** – 50 Ohms – DC Coupled, External Blocking Capacitor Needed*
2	GND	Ground – Common
3	RF1	RF1 – 50 Ohms – DC Coupled, External Blocking Capacitor Needed*
4,5	GND	Ground – Common
6	Byp2A	Optional DC to 10 GHz RF port – Pin 13 Return** – 50 Ohms – DC Coupled, External Blocking Capacitor Needed*
7	VT2	Notch Tune Voltage 2
8	VT1	Notch Tune Voltage 1
9	GND	Ground – Common
10	A#	Complement of Filter Band Select Bit C
11	B#	Complement of Filter Band Select Bit B
12	C#	Complement of Filter Band Select Bit A
13	Byp2B	Optional DC to 10 GHz RF port – Pin 6 Return** – 50 Ohms – DC Coupled, External Blocking Capacitor Needed*
14	GND	Ground – Common
15	RF2	RF2 – 50 Ohms – DC Coupled, External Blocking Capacitor Needed*
16,17	GND	Ground – Common
18	Byp1B	Optional DC to 10 GHz RF port – Pin 1 Return** – 50 Ohms – DC Coupled, External Blocking Capacitor Needed*
19	VDD	DC Power Input
20	VDD	DC Power Input
21	GND	Ground – Common
22	A	Filter Band Select Bit C
23	B	Filter Band Select Bit B
24	C	Filter Band Select Bit A
Bottom Pad	GND	Ground – Common

\*Note: DC blocking caps not required if in series with other Atlanta Micro parts of the same reference voltage.

\*\*Note: Can be used for external filtering or connected to return pin through for a filter bypass path.

# AM3129 – Filter Bank



## Analog Tunable 1.0 to 6.0 GHz Notch

### Specifications

#### Absolute Maximum Ratings

	Minimum	Maximum
Supply Voltage	-0.3 V	+6.0 V
DC Control Voltage	0.0 V	+10.0 V
RF Input Power		+27 dBm
Operating Junction Temperature	-40 C	+150 C
Storage Temperature Range	-55 C	+150 C

**Note:** Any device operation beyond the Absolute Maximum Ratings may result in permanent damage to the device. The values listed in this table are extremes and do not imply functional operation of the device at these or any other conditions beyond what is listed under Recommended Operating Conditions. Any part subjected to conditions outside of what is recommended for an extended amount of time may suffer from reliability concerns.

#### Handling Information

	Minimum	Maximum
Storage Temperature Range (Recommended)	-55 C	+125 C
Moisture Sensitivity Level	MSL 3	



Atlanta Micro products are electrostatic sensitive.  
Follow safe handling practices to avoid damage

#### Recommended Operating Conditions

	Minimum	Typical	Maximum
Supply Voltage	+2.7 V	+5.0 V	
DC Control Voltage	0.0 V		+7.0 V
Operating Case Temperature	-40 C		+85 C
Operating Junction Temperature	-40 C		+125 C

# AM3129 – Filter Bank

## Analog Tunable 1.0 to 6.0 GHz Notch

### DC Electrical Characteristics

(T = 25 °C unless otherwise specified)

Parameter	Testing Conditions	Minimum	Typical	Maximum
DC Supply Voltage		+2.7 V	+5.0 V	
DC Supply Current	V Supply = +3.3 V		24 mA	
	V Supply = +5.0 V		28 mA	
Power Dissipated	V Supply = +3.3 V		80 mW	
	V Supply = +5.0 V		140 mW	
Logic Level Low		0.0 V		+0.5 V
Logic Level High		+2.0 V		+V Supply
DC Control Voltage		+0.0 V		+7.0 V
DC Control Current			< 1 mA	

### RF Performance

(T = 25 °C, VDD = +5.0 V unless otherwise specified)

Parameter	Testing Conditions	Minimum	Typical	Maximum
Frequency Range		1.0 GHz		6.0 GHz
Bypass Frequency Range		DC		10.0 GHz
Insertion Loss			4.0 dB	
Notch Depth			30.0 dB	
Return Loss			10.0 dB	

### Timing Characteristics

Parameter	Minimum	Typical	Maximum
Switching Speed (In Band → Out of Band)		150 ns	250 ns
Switching Speed (Out of Band → In Band)		250 ns	400 ns

Note: Switching speed measured without any control line filters. Switching speed measured as time from 50% control to 50% RF.

### State Table

A	B	C	State
Low	Low	Low	Bypass 2 – DC to 10 GHz
Low	Low	High	Band 6 – 4000 MHz to 6000 MHz
Low	High	Low	Band 5 – 2800 MHz to 4500 MHz
Low	High	High	Band 4 – 2200 MHz to 3300 MHz
High	Low	Low	Band 1 – 800 MHz to 1500 MHz
High	Low	High	Band 2 – 1100 MHz to 1800 MHz
High	High	Low	Band 3 – 1600 MHz to 2500 MHz
High	High	High	Bypass 1 – DC to 10 GHz

Note: Frequencies listed in table define typical notch center frequency locations for low and high end of a given band.

# AM3129 – Filter Bank



## Analog Tunable 1.0 to 6.0 GHz Notch

### Typical Performance

(T = 25 , VDD = +5.0 V. Only some states shown for simplicity)

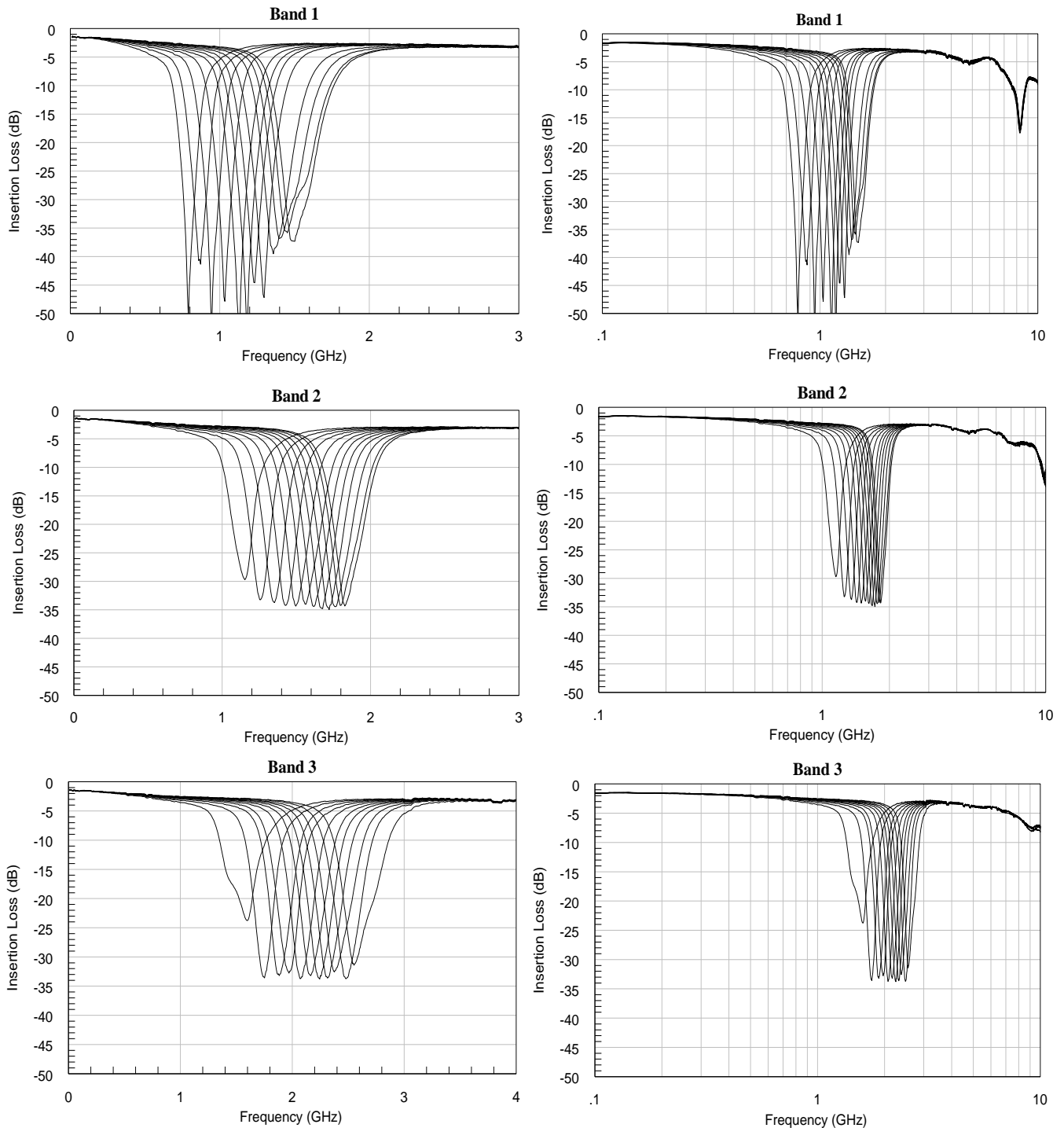

To obtain price, delivery, or to place an order contact [MMICSales@mrcty.com](mailto:MMICSales@mrcty.com)  
Atlanta Micro Inc., 3720 Davinci Ct, Suite 125, Norcross, GA 30092 • Phone: (470) 253-7640 • [www.atlantamicro.com](http://www.atlantamicro.com)

# AM3129 – Filter Bank



## Analog Tunable 1.0 to 6.0 GHz Notch

### Typical Performance (continued)

(T = 25 C, VDD = +5.0 V. Only some states shown for simplicity)

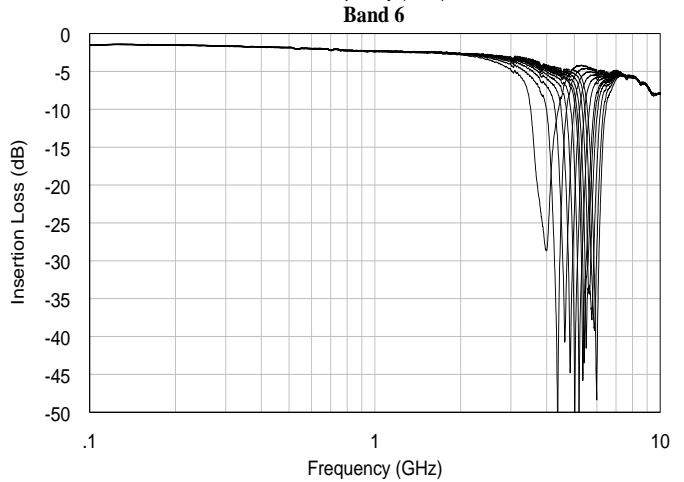
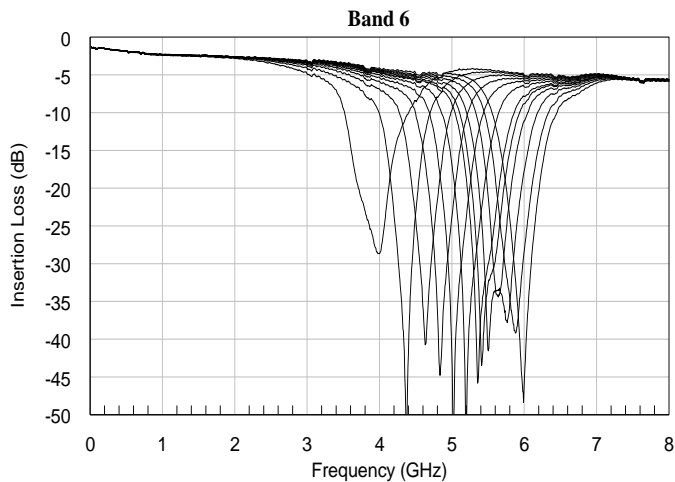
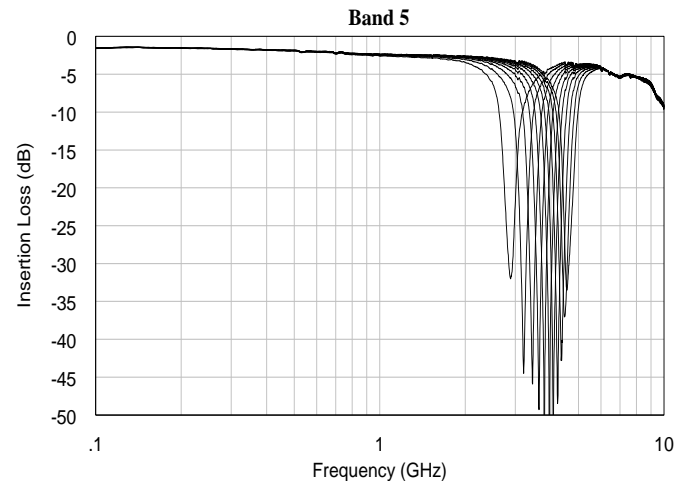
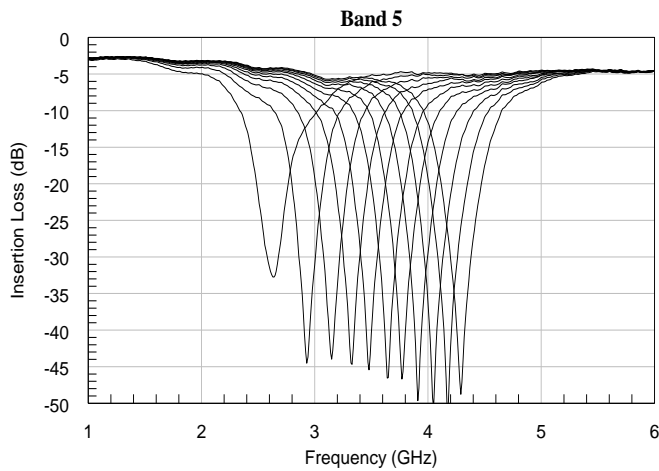
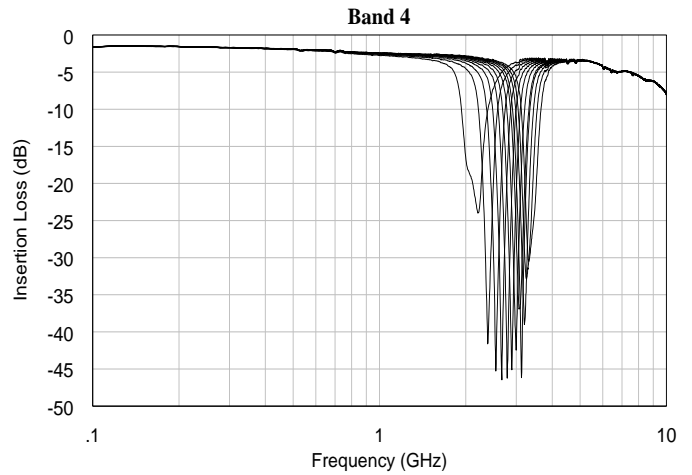
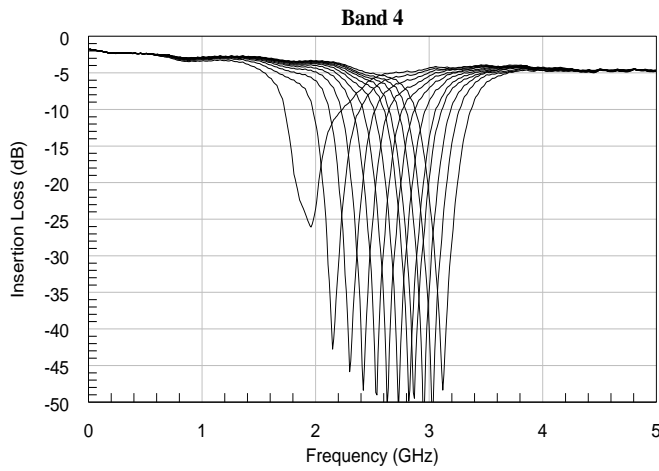

To obtain price, delivery, or to place an order contact [MMICSales@mercy.com](mailto:MMICSales@mercy.com)  
Atlanta Micro Inc., 3720 Davinci Ct, Suite 125, Norcross, GA 30092 • Phone: (470) 253-7640 • [www.atlantamicro.com](http://www.atlantamicro.com)

# AM3129 – Filter Bank



Analog Tunable 1.0 to 6.0 GHz Notch

## Typical Applications

Two Control Voltages

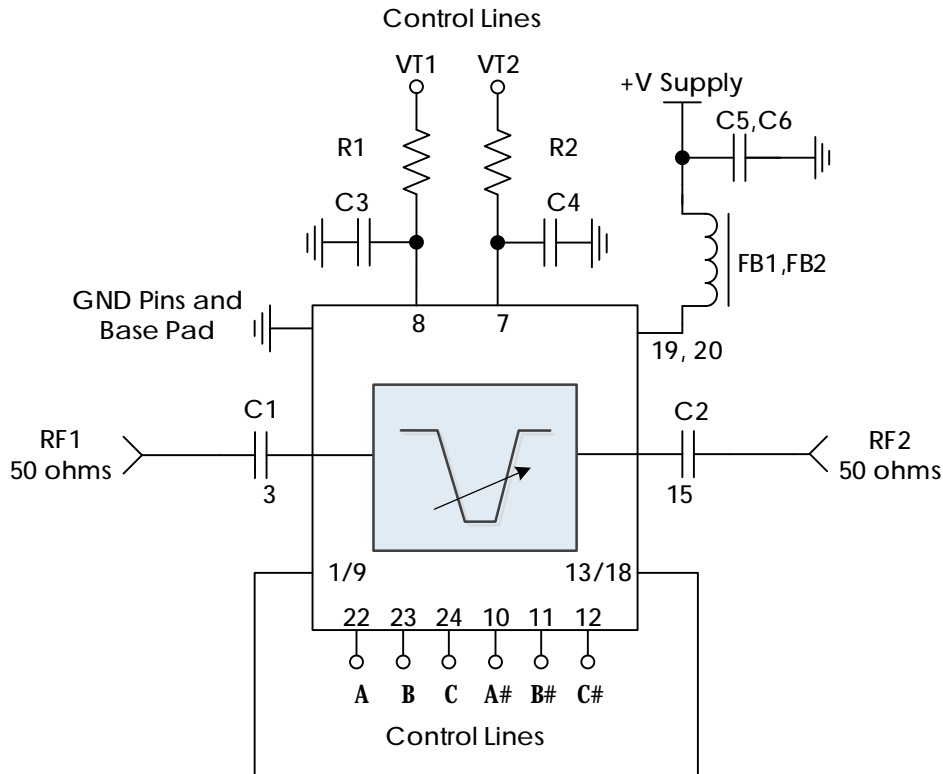

### Recommended Component List (or equivalent):

Part	Value	Part Number	Manufacturer
C1, C2	$\mu\text{F}$	0402BB104KW160	Passives Plus
C3 - C6	$\mu\text{F}$	C1005X7R1H104K050BB	TDK
FB1, FB2		MMZ1005A222E	TDK
R1, R2	$\Omega$	CRCW0402100RFKED	Vishay

### Notes:

- DC blocking capacitors should be high performance, low-loss, broadband capacitors for optimum performance.
- RC filtering on the control lines is recommended to prevent digital noise from coupling to the RF path.
- Select control line RC filter values based on desired logic source decoupling and switching speed.



# AM3129 – Filter Bank

Analog Tunable 1.0 to 6.0 GHz Notch

## Typical Applications (continued)

### Low Component Count

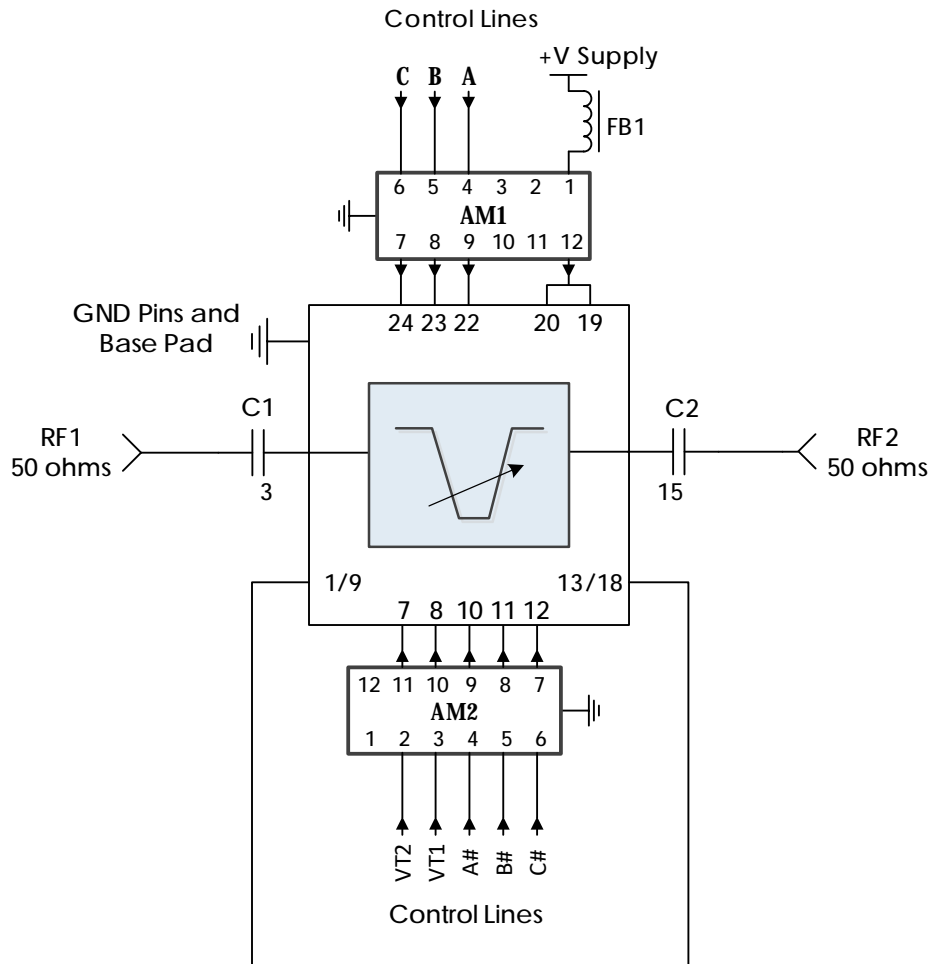

### Recommended Component List (or equivalent):

Part	Value	Part Number	Manufacturer
C1,C2	$\mu\text{F}$	0402BB104KW160	Passives Plus
FB1,FB2	-	MMZ1005A222E	TDK
AM1, AM2	-	AM35	Atlanta Micro

### Notes:

1. DC blocking capacitors should be high performance, low-loss, broadband capacitors for optimum performance.
2. AM35 provides power and control line filtering with high frequency isolation to 50+ GHz
3. See AM35 datasheet for performance details.
4. AM35 is 1.5mm x 3mm with 0.5mm pitch, making for a small form factor.

# AM3129 – Filter Bank

Analog Tunable 1.0 to 6.0 GHz Notch

## Typical Applications (continued)

### Single Control Voltage

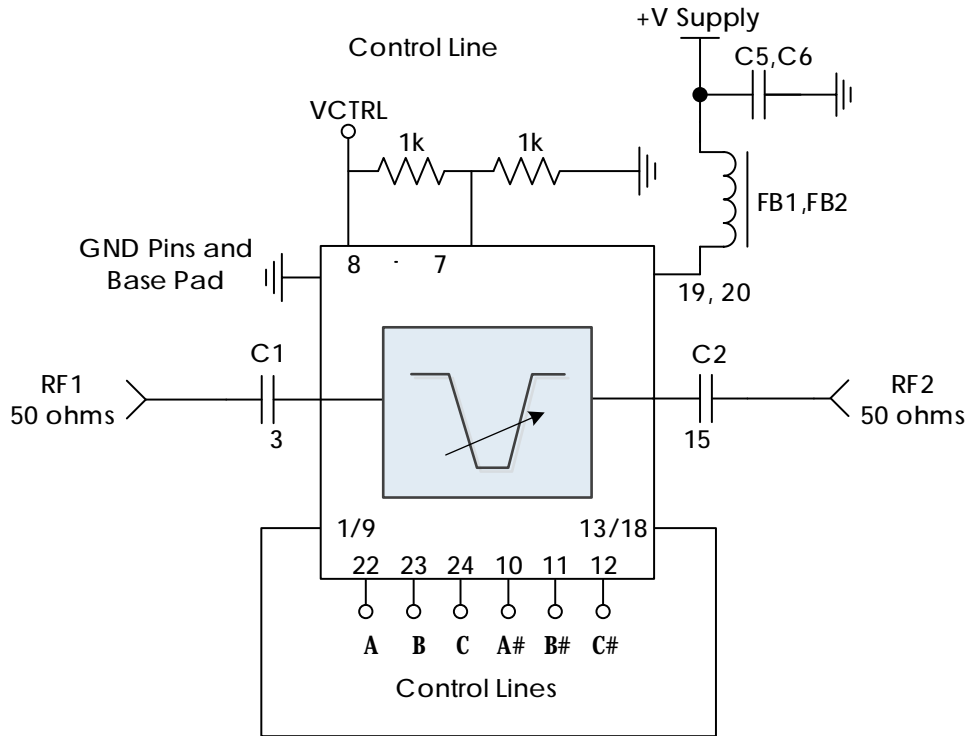

### Recommended Component List (or equivalent):

Part	Value	Part Number	Manufacturer
C1,C2	$\mu\text{F}$	0402BB104KW160	Passives Plus
C5,C6	$\mu\text{F}$	C1005X7R1H104K050BB	TDK
FB1,FB2		MMZ1005A222E	TDK

### Notes:

- DC blocking capacitors should be high performance, low-loss, broadband capacitors for optimum performance.
- The resistive divider between pins 7 and 8 exists to normalize percentage bandwidth over the full +0.0V to +6V range.
  - Tying pins 7 and 8 to the same control voltage without the divider is possible, but rejection at center frequency will likely be lower
  - 1k resistor values only an example, choose values based on desired bandwidth.
  - Evaluation board for AM3129 allows experimentation of different values for resistors.
- RC filtering on the control lines is recommended to prevent digital noise from coupling to the RF path. Select control line RC filter values based on desired logic source decoupling and switching speed.

# AM3129 – Filter Bank

Analog Tunable 1.0 to 6.0 GHz Notch

## Evaluation PC Board

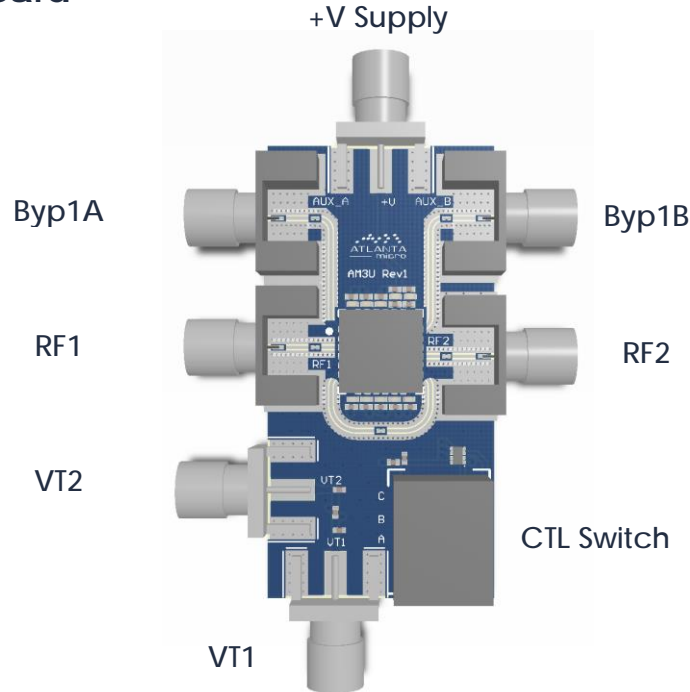

A	B	C	State
High	High	High	Bypass 2 – DC to 10 GHz (Connected on Eval)
High	High	Low	Band 6 – 2950 MHz to 6300 MHz
High	Low	High	Band 5 – 2200 MHz to 4800 MHz
High	Low	Low	Band 4 – 1700 MHz to 3500 MHz
Low	High	High	Band 1 – 550 MHz to 1700 MHz
Low	High	Low	Band 2 – 800 MHz to 2000 MHz
Low	Low	High	Band 3 – 1150 MHz to 2700 MHz
Low	Low	Low	Bypass 1 – DC to 10 GHz (Byp1A and Byp1B ports)

\*Note: Eval board logic is inverse of AM3129 logic. CBA on the eval board are connected to #C#B#A on the AM3129.

## Related Parts

Part Number	Description			
AM3089	2.0 GHz	To	18.0 GHz	Analog Tunable Bandpass Filter
AM3134	2.0 GHz	to	4.5 GHz	Analog Tunable Bandpass Filter Bank
AM3135	3.5 GHz	to	9.0 GHz	Analog Tunable Bandpass Filter Bank
AM3136	8.0 GHz	to	19.0 GHz	Analog Tunable Bandpass Filter Bank
AM3137	700 MHz	to	2000 MHz	Analog Tunable Notch Filter Bank
AM3138	1300 MHz	to	3250 MHz	Analog Tunable Notch Filter Bank
AM3139	2500 MHz	to	6000 MHz	Analog Tunable Notch Filter Bank

To obtain price, delivery, or to place an order contact [MMICSales@mercy.com](mailto:MMICSales@mercy.com)  
 Atlanta Micro Inc., 3720 Davinci Ct, Suite 125, Norcross, GA 30092 • Phone: (470) 253-7640 • [www.atlantamicro.com](http://www.atlantamicro.com)

### Component Compliance Information

**RoHS:** Atlanta Micro, Inc. hereby certifies that all products comply with the EC Directive 2011/65/EC on the Restriction of Hazardous Substances, commonly known as EU-RoHS 6 and 10. All products supplied by Atlanta Micro shall be compliant with the European Directive 2011/65/EC based on the following substance list.

Substance List	Allowable Maximum Concentration
Lead (Pb)	<1000 PPM (0.1% by weight)
Mercury (Hg)	<1000 PPM (0.1% by weight)
Cadmium (Cd)	<75 PPM (0.0075% by weight)
Hexavalent Chromium (CrVI)	<1000 PPM (0.1% by weight)
Polybrominated Biphenyls (PBB)	<1000 PPM (0.1% by weight)
Polybrominated Diphenyl ethers (PBDE)	<1000 PPM (0.1% by weight)
Decabromodiphenyl Deca BDE	<1000 PPM (0.1% by weight)
Bis (2-ethylhexyl) Phthalate (DEHP)	<1000 PPM (0.1% by weight)
Butyl Benzyl Phthalate (BBP)	<1000 PPM (0.1% by weight)
Dibutyl Phthalate (DBP)	<1000 PPM (0.1% by weight)
Diisobutyl Phthalate (DIBP)	<1000 PPM (0.1% by weight)

**REACH:** Atlanta Micro, Inc. neither uses nor intentionally adds any of the substances considered to be a Substance of Very High Concern (SVHC) as defined by the EU Regulation (EC) No. 1907-2006 on Registration, Evaluation, Authorization, and Restriction of Chemicals (REACH).

**Conflict Materials:** Atlanta Micro does not knowingly use materials that are sourced from the Democratic Republic of Congo (DRC) or any other known conflict regions. Atlanta Micro's supply chain is comprised of sources that are both environmentally and socially responsible. We periodically review this requirement with our vendors to ensure continued compliance.

Atlanta Micro takes its responsibility as a global partner seriously and will use due diligence within our supply chain to ensure all standards are met to the best of our knowledge.