

AM1111 – Amplifier

2 GHz to 18 GHz Gain Block

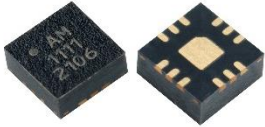

AM1111 is a wideband, cascadable amplifier servicing the 2 to 18 GHz frequency range. The device exhibits exceptional linearity and power handling capabilities across its bandwidth, while maintaining moderate gain and noise figure. Packaged in a 3mm QFN with internal 50Ω matching and DC blocking capacitors on input and output, AM1111 represents a compact total PCB footprint.

FEATURES

- 16 dB Gain
- 2.5 dB Noise Figure
- +32 dBm OIP3
- +21 dBm P1dB
- +5.0V Operation
- 500 mW Power Consumption
- 3mm QFN
- -40C to +85C Operation

FUNCTIONAL DIAGRAM

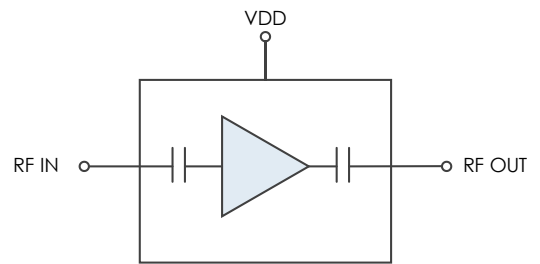

CHARACTERISTIC PERFORMANCE

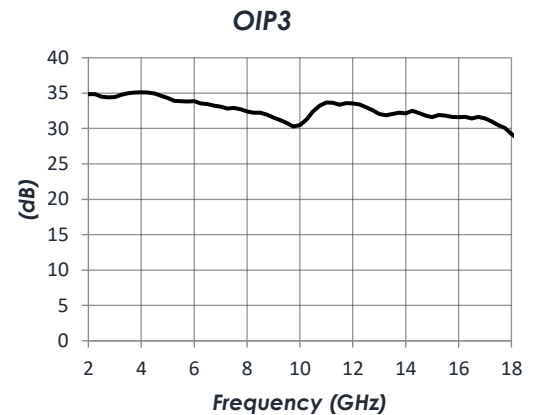
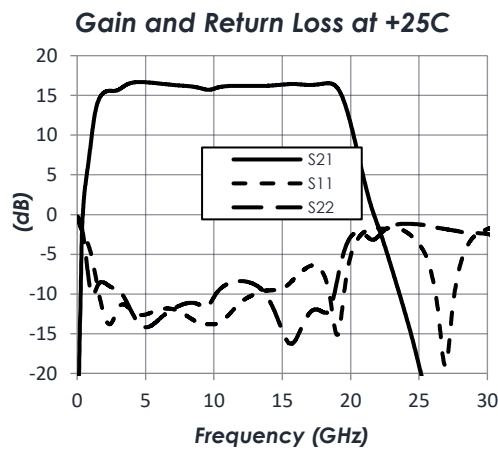

CONTENTS

FEATURES 1

FUNCTIONAL DIAGRAM 1

CHARACTERISTIC PERFORMANCE 1

REVISION HISTORY..... 2

PIN LAYOUT AND DEFINITIONS 3

SPECIFICATIONS..... 4

TYPICAL PERFORMANCE 6

TYPICAL APPLICATION..... 8

EVALUATION PC BOARD..... 9

RELATED PARTS..... 9

COMPONENT COMPLIANCE INFORMATION 10

REVISION HISTORY

Date	Revision	Notes
April 13, 2021	1	Initial Release
July 28, 2022	2	Corrected Eval Board.
January 30, 2024	3	Updated Thermal Information
June 17, 2024	4	Changed to Mercury branding. No content changes.
April 21, 2026	4.1	Corrected pinout diagram

PIN LAYOUT AND DEFINITIONS

Note: All Un-Labeled Pins are NC or Ground

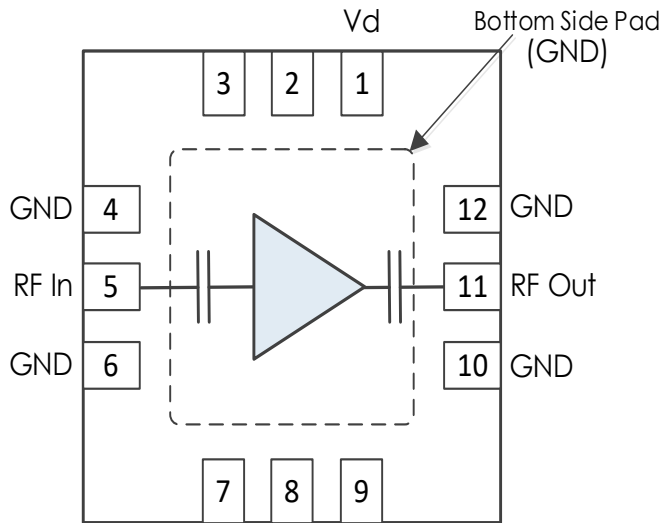

	Name	Function
1	Vd	DC Power Input
2-3	NC	Not Connected
4	GND	Ground - Common
5	RF In	RF Input - 50 Ohms - DC Blocked
6	GND	Ground - Common
7-9	NC	Not Connected
10	GND	Ground - Common
11	RF Out	RF Output - 50 Ohms - DC Blocked
12	GND	Ground - Common

NC pins may be grounded or left open.

SPECIFICATIONS

Absolute Maximum Ratings

	Minimum	Maximum
Supply Voltage	-0.3 V	+5.5 V
RF Input Power		+20 dBm
Storage Temperature Range	-55C	+150 C

Note: Any device operation beyond the Absolute Maximum Ratings may result in permanent damage to the device. The values listed in this table are extremes and do not imply functional operation of the device at these or any other conditions beyond what is listed under Recommended Operating Conditions. Devices subjected to conditions outside of what is recommended for extended periods may affect device reliability.

Handling Information

	Minimum	Maximum
Moisture Sensitivity Level	MSL 3	



Mercury products are electrostatic sensitive.
Follow safe handling practices to avoid damage.

Recommended Operating Conditions

	Minimum	Typical	Maximum
Supply Voltage (VDD)	+4.8 V	+5.0 V	+5.2 V
Operating Case Temperature	-40 C		+85 C

Thermal Information

Junction to Case Thermal Resistance (θ_{JC})	137 C/W
Nominal Junction Temperature at +85 C ambient	+153 C
Channel Temperature to Maintain 1 Million Hour MTTF	+175 C

DC Electrical Characteristics

(T = 25 °C unless otherwise specified)

Param	Testing Conditions	Min	Typical	Max
DC Supply Voltage	VD		+5.0 V	
DC Supply Current	VD = +5.0V		100 mA	
Power Dissipated	VD = +5.0V		500 mW	

RF Performance

(T = 25 °C unless otherwise specified)

Param	Testing Conditions	Min	Typical	Max
Frequency Range		2 GHz		18 GHz
Gain	f = 2 GHz		15 dB	
	f = 10 GHz		16 dB	
	f = 18 GHz		16 dB	
Return Loss	f = 2 GHz		10 dB	
	f = 10 GHz		11 dB	
	f = 18 GHz		9 dB	
Output IP3	f = 10 GHz		31 dBm	
Output P1dB	f = 10 GHz		21 dBm	
Noise Figure	f = 10 GHz		2 dB	

TYPICAL PERFORMANCE

(VD = +5.0V, T = 25°C unless otherwise specified)

Gain vs Temperature

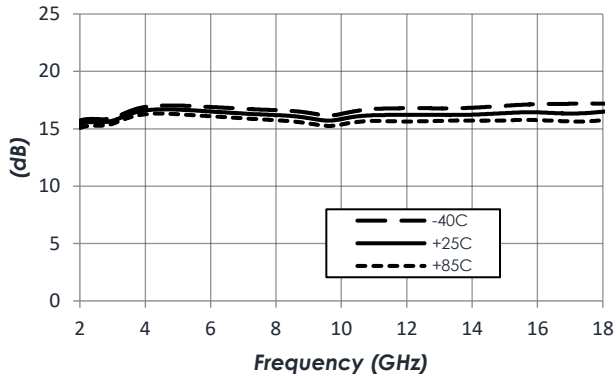

Noise Figure vs Temperature

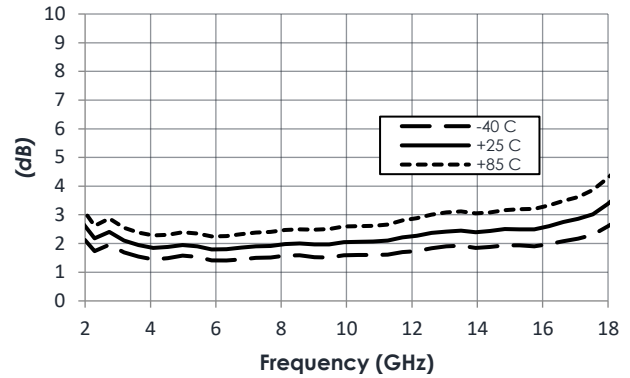

Output IP3 vs Temperature

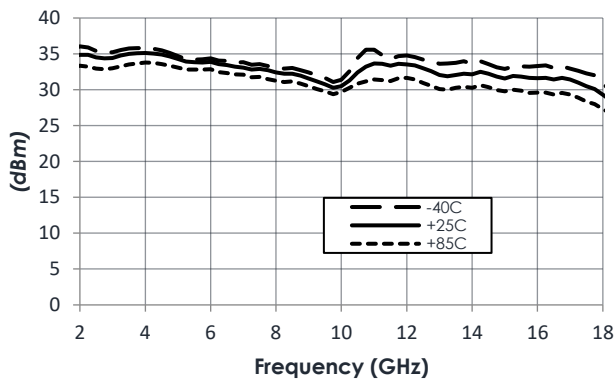

P1dB vs Temperature

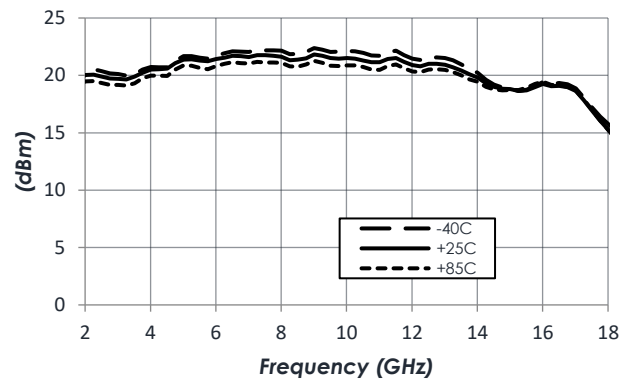

Reverse Isolation vs Temperature

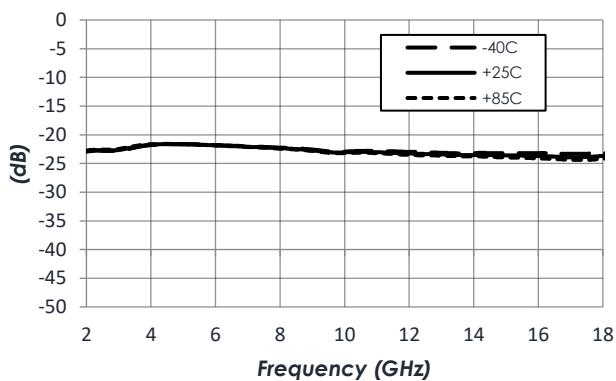

TYPICAL PERFORMANCE (CONTINUED)

(VD = +5.0V, T = 25°C unless otherwise specified)

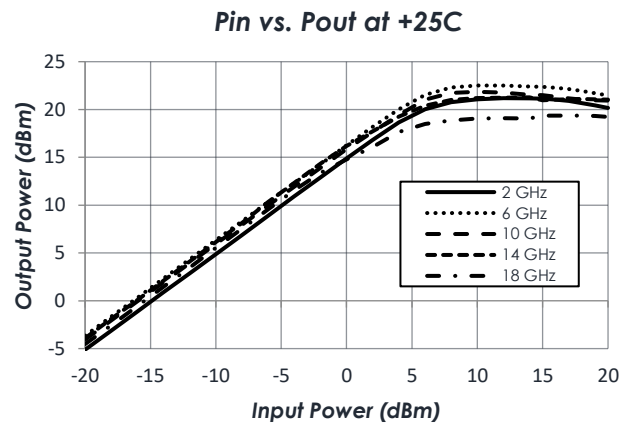
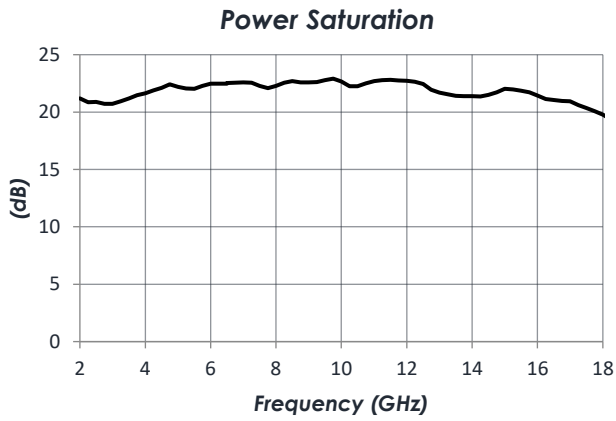

TYPICAL APPLICATION

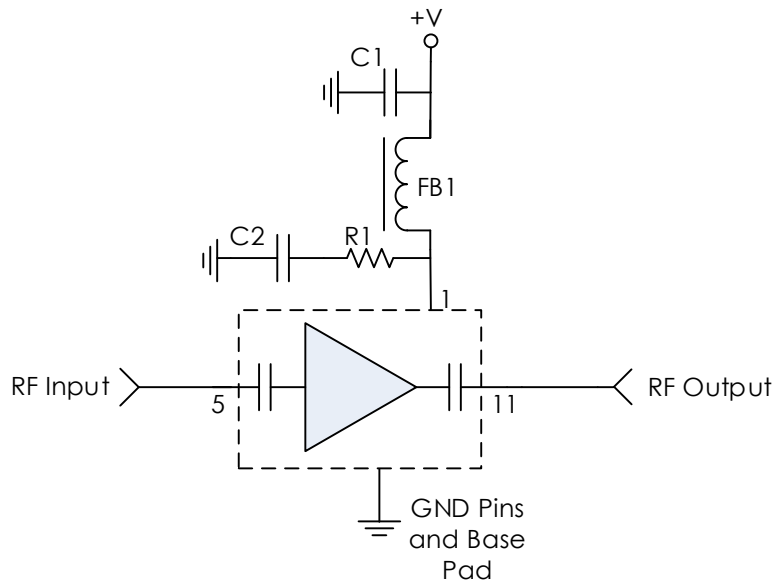

Note: NC pins may be grounded or left open

Recommended Component List (or Equivalent)

Part	Value	Part Number	Manufacturer
C1	0.1 μ F	GRM155R71C104KA88	Murata
FB1	-	MMZ1005A222E	TDK
R1	15 Ohms	CRCW040215R0FKED	Vishay
C2	10 μ F	CL05A106MP8NUB8	Samsung

Notes:

1. RF Input and Output pins are internally DC blocked.
2. R1, C1, and C2 are required for proper operation of the AM1111.

EVALUATION PC BOARD

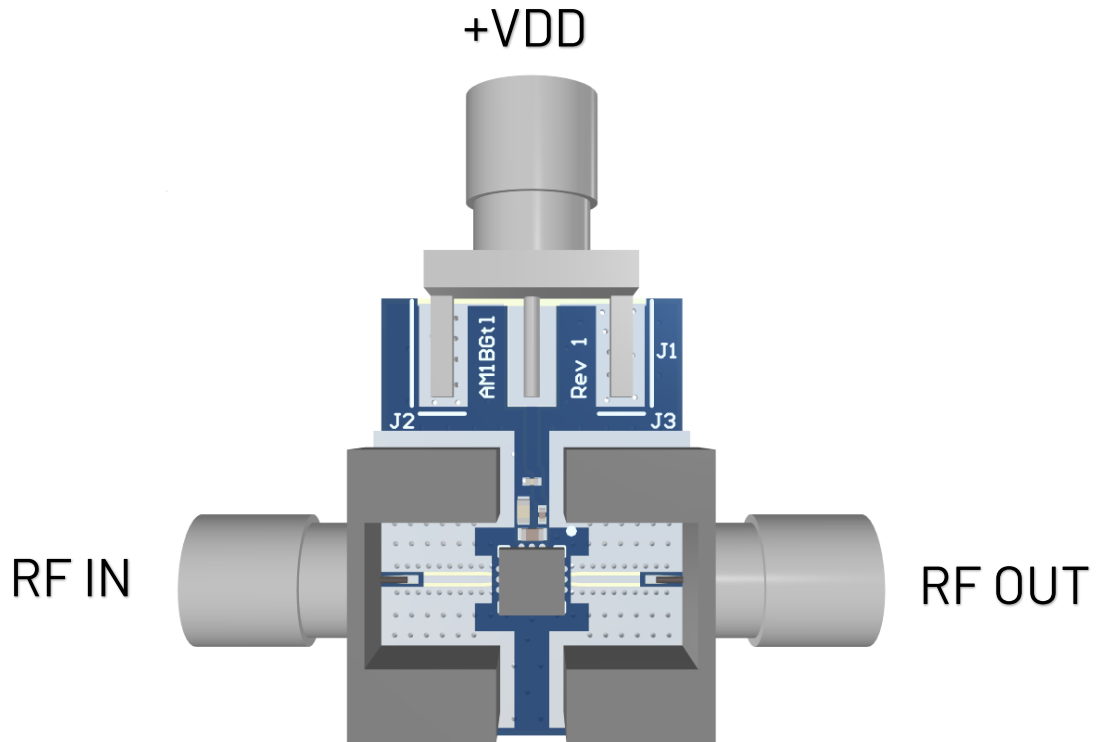

Note: Not all components shown may be installed.

RELATED PARTS

Part Number		Description
AM1053	5 GHz to 20 GHz	Gain Block
AM1067	5 GHz to 20 GHz	Bypassable Gain Block
AM1070	DC to 18 GHz	Broadband Gain Block
AM1071	DC to 18 GHz	Broadband Gain Block
AM1077	5 GHz to 20 GHz	Bypassable Gain Block w/ Isolation State
AM1100	2 GHz to 26.5 GHz	Low Noise Amplifier
AM1101	2 GHz to 26.5 GHz	Bypassable Amplifier
AM1102	DC to 22 GHz	Low Noise Amplifier

COMPONENT COMPLIANCE INFORMATION

RoHS: Mercury Systems, Inc. hereby certifies that all products comply with the EC Directive 2011/65/EC on the Restriction of Hazardous Substances, commonly known as EU-RoHS 6 and 10. All products supplied by Mercury shall be compliant with the European Directive 2011/65/EC based on the following substance list.

Substance List	Allowable Maximum Concentration
Lead (Pb)	<1000 PPM (0.1% by weight)
Mercury (Hg)	<1000 PPM (0.1% by weight)
Cadmium (Cd)	<75 PPM (0.0075% by weight)
Hexavalent Chromium (CrVI)	<1000 PPM (0.1% by weight)
Polybrominated Biphenyls (PBB)	<1000 PPM (0.1% by weight)
Polybrominated Diphenyl ethers (PBDE)	<1000 PPM (0.1% by weight)
Decabromodiphenyl Deca BDE	<1000 PPM (0.1% by weight)
Bis (2-ethylhexyl) Phthalate (DEHP)	<1000 PPM (0.1% by weight)
Butyl Benzyl Phthalate (BBP)	<1000 PPM (0.1% by weight)
Dibutyl Phthalate (DBP)	<1000 PPM (0.1% by weight)
Diisobutyl Phthalate (DIBP)	<1000 PPM (0.1% by weight)

REACH: Mercury Systems, Inc. neither uses nor intentionally adds any of the substances considered to be a Substance of Very High Concern (SVHC) as defined by the EU Regulation (EC) No. 1907-2006 on Registration, Evaluation, Authorization, and Restriction of Chemicals (REACH).

CONFLICT MATERIALS: Mercury does not knowingly use materials that are sourced from the Democratic Republic of Congo (DRC) or any other known conflict regions. Mercury’s supply chain is comprised of sources that are both environmentally and socially responsible. We periodically review this requirement with our vendors to ensure continued compliance.

Mercury takes its responsibility as a global partner seriously and will use due diligence within our supply chain to ensure all standards are met to the best of our knowledge.



Corporate Headquarters

50 Minuteman Road
 Andover, MA 01810 USA
 +1 978.967.1401 tel
 +1 866.627.6951 tel
 +1 978.256.3599 fax

International Headquarters

Mercury International
 Avenue Eugène-Lance, 38
 PO Box 584
 CH-1212 Grand-Lancy 1
 Geneva, Switzerland
 +41 22 884 5100 tel

Learn more

Visit: mrcy.com

For pricing details, contact: MMICsales@mrcy.com

For technical details, contact: MMICsupport@mrcy.com



The Mercury Systems logo is a registered trademark of Mercury Systems, Inc. Other marks used herein may be trademarks or registered trademarks of their respective holders. Mercury products identified in this document conform with the specifications and standards described herein. Conformance to any such standards is based solely on Mercury’s internal processes and methods. The information contained in this document is subject to change at any time without notice.

