

# AM3103 – Filter Bank

## Digitally Tunable 1.0 to 3.0 GHz Bandpass

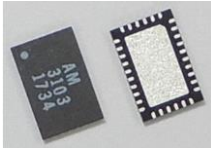

AM3103 is a miniature filter IC containing digitally tunable bandpass filters covering the 1.0 GHz to 3.0 GHz frequency range. Independent 4-bit digital control of the low-pass and high-pass corners provide control of both center frequency and bandwidth. AM3103 provides an excellent filtering solution for a receiver or transceiver requiring flexible center frequency and bandwidth, high dynamic range, and small size, weight, and power consumption.

### Features

- Digitally Tunable Bandpass Filters
- Independent LP and HP control
- 4-bit Control, 3V or 5V Logic
- +3.3V to +5.0V Supply
- Integrated Control Line Filtering
- 3 dB Insertion Loss
- 4.0 x 6.0 mm QFN Package
- +40 dBm Input IP3
- 40C to +85C Operation

### Functional Diagram

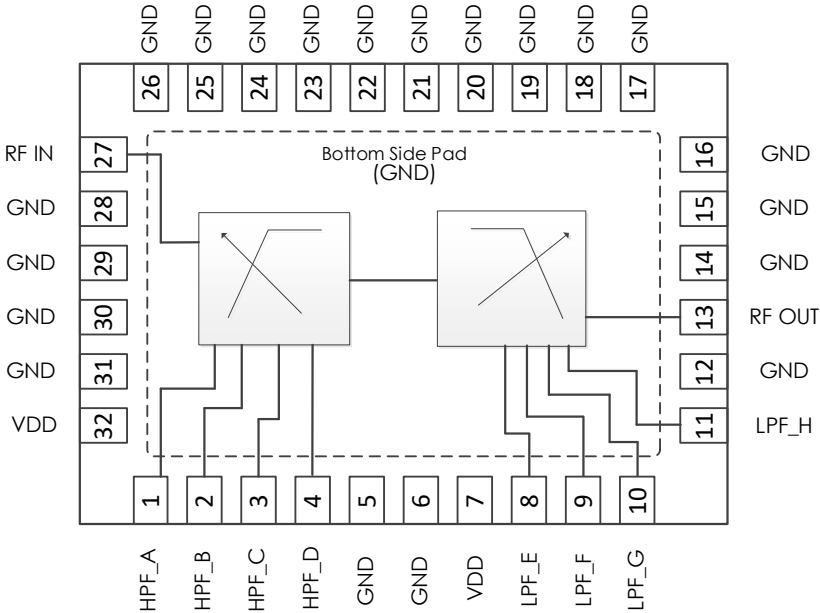

# AM3103 – Filter Bank

## Digitally Tunable 1.0 to 3.0 GHz Bandpass

### Typical Performance

**Note:** Only some of the available states shown for simplicity.

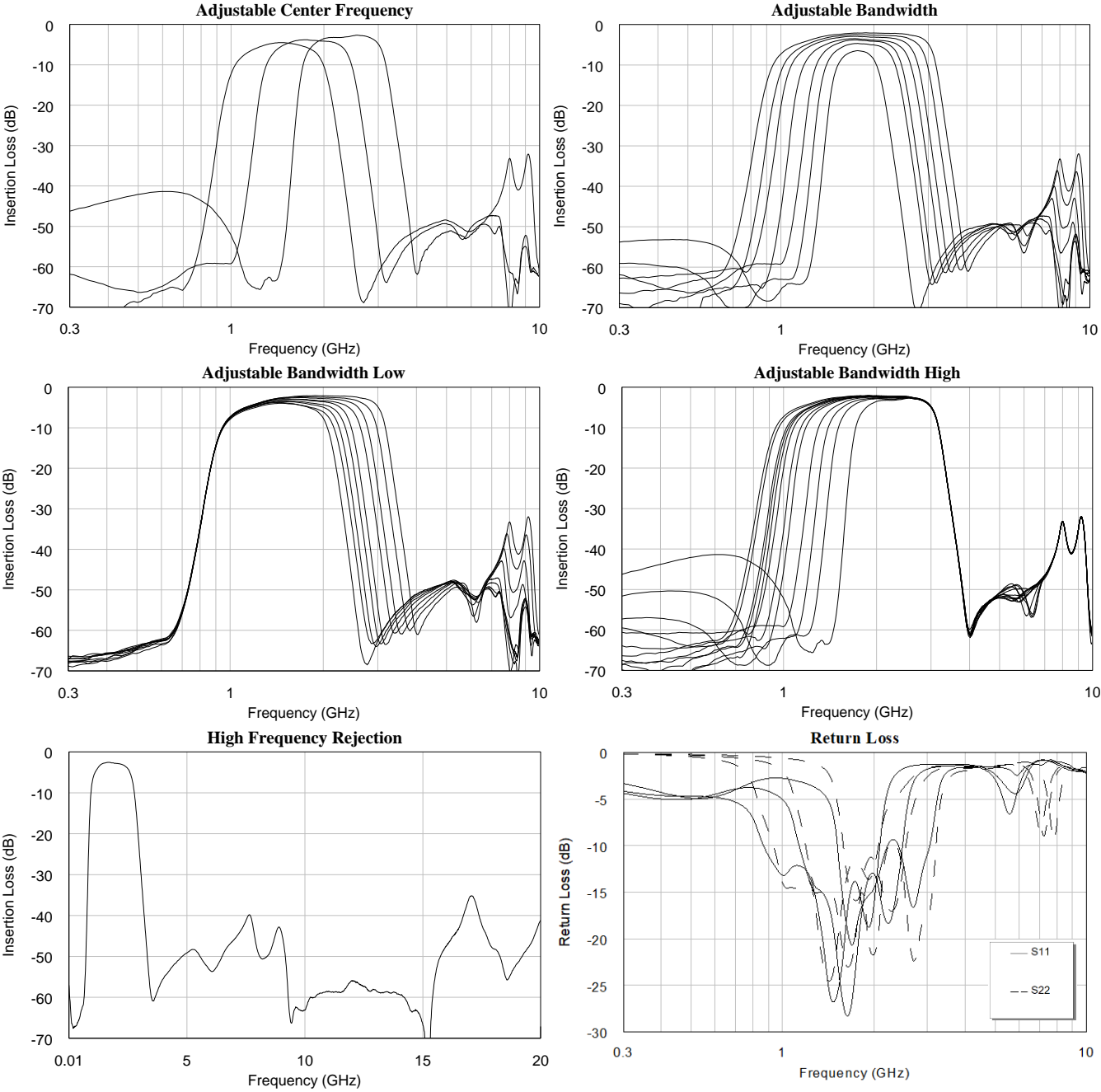

# AM3103 – Filter Bank

## Digitally Tunable 1.0 to 3.0 GHz Bandpass

### Typical Applications Schematic

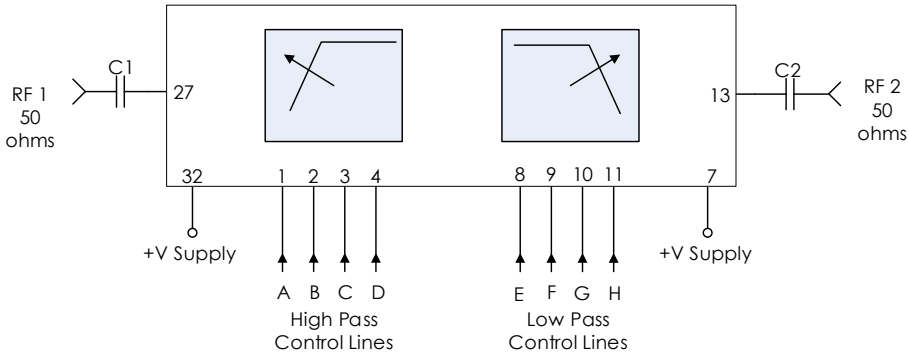

### Recommended Component List (or equivalent):

Part	Value	Part Number	Manufacturer
C1, C2	0.1 uF	0402BB104KW160	Passives Plus

**Notes:**

1. RF blocking capacitors should be high performance, low-loss, broadband capacitors for optimum performance.
2. VDD and control lines filtered internally providing high-frequency isolation to 20+ GHz.

# AM3103 – Filter Bank

## Digitally Tunable 1.0 to 3.0 GHz Bandpass

### Pin Definitions

Pin Number	Name	Function
1	HPF_A	High pass filter control A
2	HPF_B	High pass filter control B
3	HPF_C	High pass filter control C
4	HPF_D	High pass filter control D
5,6	GND	Ground
7	VDD	DC Power Input
8	LPF_E	Low pass filter control E
9	LPF_F	Low pass filter control F
10	LPF_G	Low pass filter control G
11	LPF_H	Low pass filter control H
12	GND	Ground
13	RF OUT	RF output – 50 ohms – DC coupled. External DC blocking capacitor required.
14-26	GND	Ground
27	RF IN	RF Input – 50 ohms – DC coupled. External DC blocking capacitor required.
28-31	GND	Ground
32	VDD	DC Power Input

### Specifications

Specifications	Minimum	Typical	Maximum
Frequency Range	1.0 GHz		3.0 GHz
Insertion Loss		2.9dB	
Input IP3		+40dBm	
RF Input Level			+27dBm
Switching Speed			1 $\mu$ s
Logic Level Low	-0.1V		+0.5V
Logic Level High	+2.0V		+5.0V
Package Size		4.0 x 6.0 x 0.9 mm	
DC Supply Voltage	+3.1V		+5.2V
DC Supply Current		2mA	
Power Consumption		10mW	
Operating Temperature	-40 C		+85 C
Storage Temperature	-50 C		+125 C

# AM3103 – Filter Bank

## Digitally Tunable 1.0 to 3.0 GHz Bandpass

### State Tables

High Pass Control Lines				Typical Cutoff Frequency (GHz)
D	C	B	A	
L	L	L	L	1.00
L	L	L	H	1.01
L	L	H	L	1.02
L	L	H	H	1.03
L	H	L	L	1.06
L	H	L	H	1.08
L	H	H	L	1.10
L	H	H	H	1.12
H	L	L	L	1.14
H	L	L	H	1.16
H	L	H	L	1.20
H	L	H	H	1.25
H	H	L	L	1.37
H	H	L	H	1.47
H	H	H	L	1.60
H	H	H	H	1.82

Low Pass Control Lines				Typical Cutoff Frequency (GHz)
H	G	F	E	
L	L	L	L	1.50
L	L	L	H	1.55
L	L	H	L	1.59
L	L	H	H	1.65
L	H	L	L	1.70
L	H	L	H	1.78
L	H	H	L	1.84
L	H	H	H	1.92
H	L	L	L	2.00
H	L	L	H	2.10
H	L	H	L	2.20
H	L	H	H	2.33
H	H	L	L	2.49
H	H	L	H	2.67
H	H	H	L	2.86
H	H	H	H	3.12

# AM3103 – Filter Bank

## Digitally Tunable 1.0 to 3.0 GHz Bandpass

### Package Details

