

TYPICAL APPLICATION

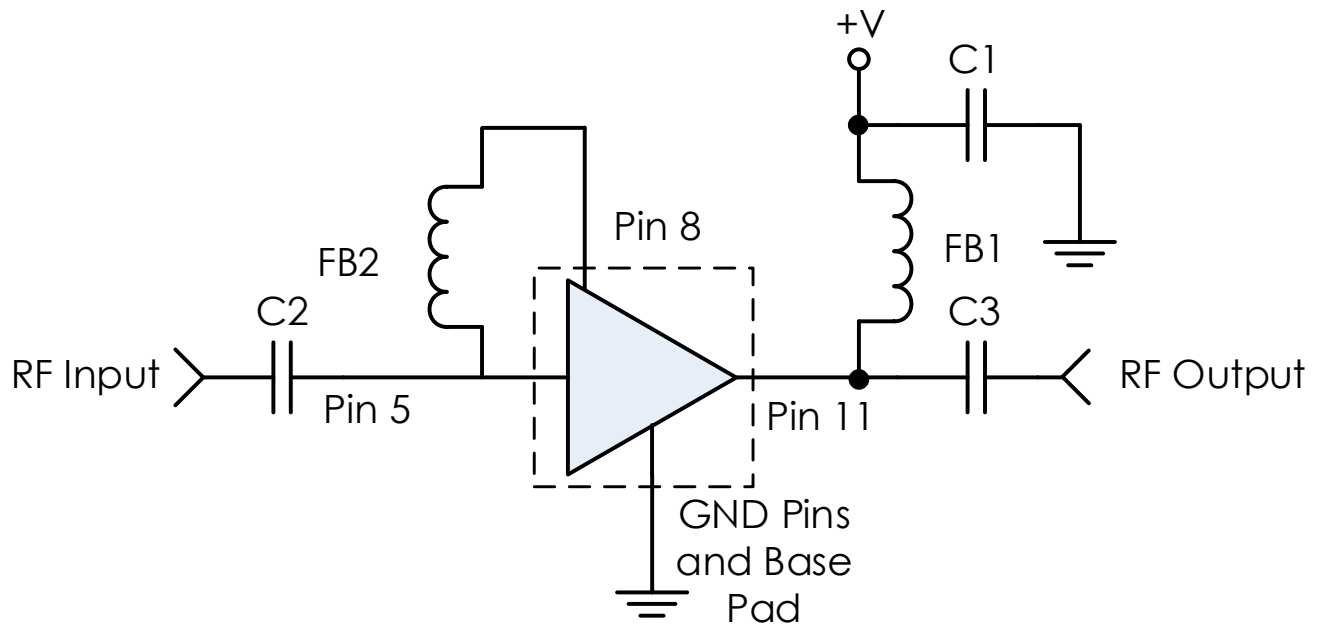

RECOMMENDED COMPONENT LIST (OR EQUIVALENT)

Part	Value	Part Number	Manufacturer
C1	0.1 uF	GRM155R71C104KA88	Murata
C2, C3	0.1 uF	0201BB104KW160	Passives Plus
FB1, FB2	-	MMZ1005A222E	TDK

Notes:

1. Application shown above is the minimum needed for an operational circuit.
2. The circuit in the recommended layout is representative of the s-parameters as available on the website.
 - a. The recommended layout adds extra components to increase power line isolation and improve performance vs frequency.
3. To choose the best component for FB2, Atlanta Micro recommends the following:
 - a. First, determine your desired frequency range of operation.
 - b. Next, design your output bias tee (FB1/C1 + any other components) for your desired power supply isolation and chosen frequency range.
 - c. The component used for FB2 should then be component(s) as used in your bias tee that connect to the main RF output (pin 11) line only.
 - i. This does not need to be the whole bias tee design.
 - ii. In the example above, FB2 = FB1.

RECOMMENDED LAYOUT

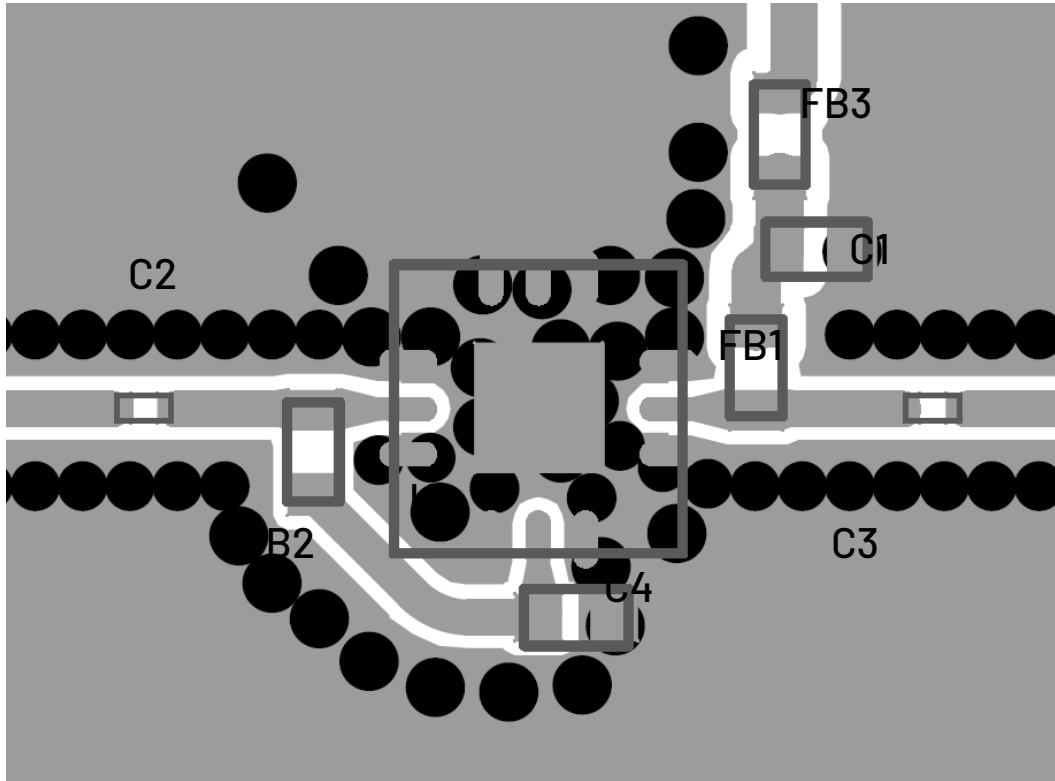

Notes:

1. FB6 = FB1 = MMZ1005A222E for symmetry..
2. C4 = C1 = GRM155R71C104KA88. C4 recommended for better performance across frequency.
3. Recommended input trace is grounded coplanar waveguide, 50 ohms.
4. IC and RF input / output should be via fenced.
5. Vias should be placed under IC and GND pads.
6. FBx and Cx may be 0201 components to minimize space used. It is not recommended to use components larger than 0402 due to extra parasitic inductance/capacitance of the larger component sizes.

REVISION HISTORY

Date	Revision	Notes
January 21, 2021	1	Initial release.
August 13, 2024	2	Changed to Mercury branding. No content changes.

For more information, contact: MMICsupport@mrcy.com

The Mercury Systems logo is a registered trademark of Mercury Systems, Inc. Other marks used herein may be trademarks or registered trademarks of their respective holders. Mercury products identified in this document conform with the specifications and standards described herein. Conformance to any such standards is based solely on Mercury's internal processes and methods. The information contained in this document is subject to change at any time without notice.

© 2024 Mercury Systems, Inc. 2-0-2024-08-13-AN-3mm_12L_FBAmplifier