

# Model 5292

## High-speed synchronizer and distribution 3U VPX board

Synchronizes up to four Cobalt, Onyx, Flexor, or Jade I/O boards

- Synchronizes sampling and data acquisition for multichannel systems
- Synchronizes gating and triggering functions
- Clock rates up to 1.8 GHz
- Front panel MMCX connectors for input signals



**The 5292 High-Speed Synchronizer and Distribution 3U VPX Board synchronizes multiple Cobalt, Onyx, Flexor, or Jade boards within a system.** It enables synchronous sampling and timing for a wide range of multichannel high-speed data acquisition, DSP, and software radio applications.

Up to four boards can be synchronized using the 5292, with each receiving a common clock along with timing signals that can be used for synchronizing, triggering and gating functions. Model 5292 is compatible with the products listed in [Supported Products](#).

### INPUT SIGNALS

Model 5292 provides three front panel MMCX connectors to accept input signals from external sources: one for clock, one for gate or trigger and one for a synchronization signal. Clock signals can be applied from an external source such as a high performance sine-wave generator. Gate/trigger and sync signals can come from an external system source. In addition to the MMCX connector, a reference clock can be accepted through the first front panel  $\mu$ Sync output connector, allowing a single Cobalt, Onyx, Flexor, or Jade board to generate the clock for all subsequent boards in the system.

### OUTPUT SIGNALS

The 5292 provides four front panel  $\mu$ Sync output connectors, compatible with a range of high-speed Cobalt, Onyx, Flexor, and Jade boards. The  $\mu$ Sync signals include a reference clock, gate/trigger and sync signals and are distributed through matched cables, simplifying system design.

**BLOCK DIAGRAM**

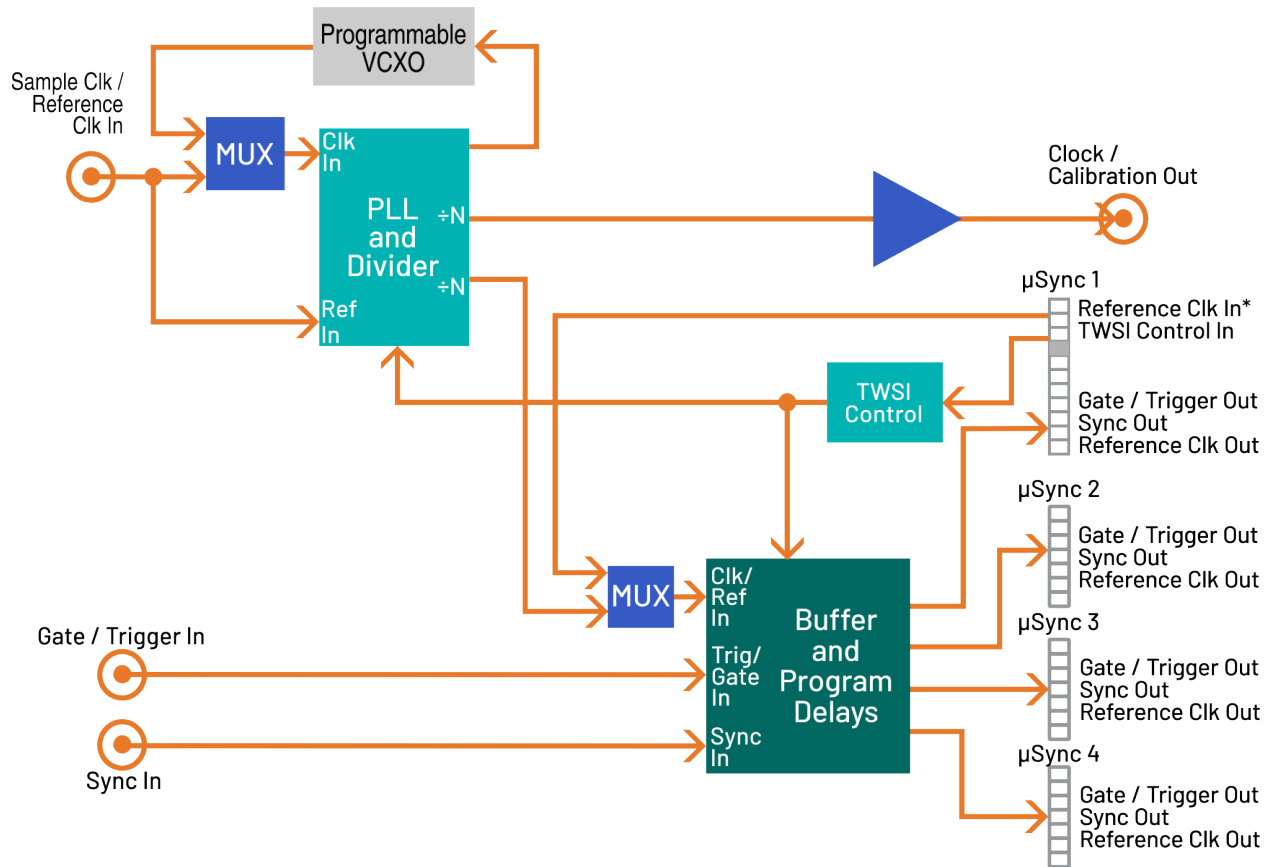

**GATE AND SYNCHRONIZATION SIGNALS**

The 5292 features separate inputs for gate/trigger and sync signals. A programmable delay allows the user to make timing adjustments on the gate/trigger and sync signals before they are sent to buffers for output through the μSync output connectors.

**CALIBRATION**

The 5292 features a calibration output specifically designed to work with the 52640 or 52740 3.6 GHz A/D board and provide a signal reference for phase adjustment across multiple D/As.

**CLOCK SIGNALS**

The 5292 can accept a user-supplied external clock on its front panel MMCX connector. As an alternative to the external clock, the 5292 can use its on-board programmable voltage controlled crystal oscillator (VCXO) as the clock source. The VCXO can operate alone or be locked to a system reference clock signal delivered to the front panel reference clock input.

The external or on-board clock can operate at full rate or be divided and used to register all sync and gate/trigger signals as well as providing a reference clock to all connected boards. In addition, the clock is available at the Clock Out MMCX as a sample or reference clock for other boards in the system.

**PROGRAMMING**

The 5292 allows programming of operating parameters including: VCXO frequency, clock dividers, and delays that allow the user to make timing adjustments on the gate and sync signals. These adjustments are made before they are sent to buffers for output through the μSync connectors.

The 5292 is programmed via a TWSI control interface on the first μSync connector. The control interface is compatible with the front panel μSync connectors of all high-speed Cobalt, Onyx, Flexor, and Jade modules, thereby providing a single cable connection that carries both control and timing signals.

**FRONT PANEL CONNECTIONS**

The front panel includes four  $\mu$ Sync input/output connectors, four MMCX connectors, and two LEDs. Note that the  $\mu$ Sync output connectors are custom-wired and NOT compatible with standard  $\mu$ HDMI cables. Use the cables described in Accessories.

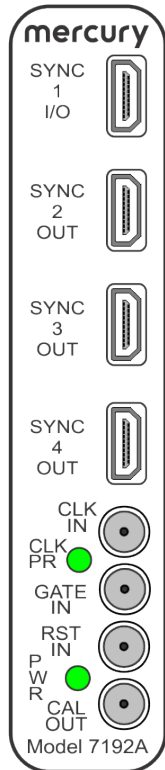

▪ **Synchronization In/Out:** A  $\mu$ Sync 19-pin connector, labeled **SYNC I/O**, provides a reference clock input and TWSI control input; and sync, reference clock, and gate outputs for synchronizing multiple boards. This connector includes TWSI (I2C) bus pins which allow a Cobalt or Onyx board to control the 7192.

▪ **Synchronization Outputs:** Three front-panel  $\mu$ Sync 19-pin connectors, labeled **SYNC 2 OUT**, **SYNC 3 OUT**, and

**SYNC 4 OUT**, provide sync, reference clock, and gate outputs for synchronizing multiple Cobalt or Onyx boards.

- **Sample Clock / Reference Input:** An MMCX connector, labeled **CLK IN**, is used for a sample clock or reference input.
- **Clock Present LED:** A green LED labeled **CLK PR** illuminates when the sample clock is working.
- **Gate/Trigger Input:** An MMCX connector, labeled **GATE IN**, is used for a gate/trigger LVTTTL input (do not exceed 3.3V).

- **SYNC Input:** An MMCX connector, labeled **SYNC IN**, is used for a sync LVTTTL input (do not exceed 3.3V).
- **Power LED:** A green LED labeled **PWR** illuminates when a +5VDC is applied to the board.
- **Clock/Calibration Output:** An MMCX connector, labeled **CAL OUT** is used for clock/calibration output.

**SUPPORTED PRODUCTS**

The 5292 supports the following Jade, Onyx, Cobalt, and Flexor products:

- Jade models 52131, 52132, 52141, and 52841
- Flexor models 5973-312, 5973-313, 5973-316, 5973-317, 5973-320, and 5973-324
- Onyx models 52730 and 52741
- Cobalt models 52630, 52640, 52641, 52670, 52671

**SOFTWARE**

If you are using a Cobalt, Onyx, or Flexor board in conjunction with 5292, software support is provided by Mercury's ReadyFlow<sup>®</sup> Board Support Packages (BSP). There is a ReadyFlow BSP to support 5292 and a separate ReadyFlow BSP to support the Cobalt, Onyx, or Flexor board.

If you are using a Jade board in conjunction with 5292, software support is provided by Mercury's Navigator<sup>®</sup> Board Support Package (BSP). In addition to supporting the Jade board, Navigator BSP supports 5292 via the I2C interface on the Jade board.

**SPECIFICATIONS**

**Front Panel Sample Clock/Reference Input**

- Connector Type: MMCX
- Input Impedance: 50 ohms
- Input Level: 0 dBm to +10 dBm, sine wave
- Sample Clock Frequency: 100 MHz to 2 GHz
- Reference Frequency: 5 to 100 MHz

**Front Panel Gate/Trigger & Sync Inputs**

- Connector Type: MMCX
- Input Level: LVTTTL

**Front Panel  $\mu$ Sync Inputs/Outputs**

- Quantity: 4
- Connector Type: 19-pin  $\mu$ HDMI
- Signal Level: CML
- Signals ( $\mu$ Sync connector 1): Reference Clock In, TWSI control In, Reference Clock Out, Gate/Trigger Out, Sync Out
- Signals ( $\mu$ Sync connectors 2-4): Reference Clock Out, Gate/Trigger Out, Sync Out

**Front Panel Clock / Calibration Output**

- Connector Type: MMCX
- Output Impedance: 50 ohms
- Output Level: +6 dBm nominal, sine wave
- Sample Clock Frequency: 100 MHz to 1.8 GHz

**Programmable VCXO**

- Frequency Ranges: 10-945 MHz, 970-1134 MHz, and 1213-1417.5 MHz
- Tuning Resolution: 32 bits
- Unlocked Accuracy:  $\pm 20$  ppm

**PLL, Divider & Jitter Cleaner**

- Type: Texas Instruments CDCM7005
- Frequency Dividers: 1, 2, 3, 4, 6, 8 and 16

**PCI Express Interface**

- PCIe Bus: x4, Power only

**Environmental**

Operating Temp: 0° to 50° C

Storage Temp: -20° to 90° C

Relative Humidity: 0 to 95%, non-cond.

**Size**

3.937 in x 6.717 in (100.00 mm x 170.61 mm)

**ORDERING INFORMATION**

Model	Description
5292	High-Speed Synchronizer and Distribution Board - 3U VPX

**ACCESSORY PRODUCTS**

Model	Description
	4 ea. 18" µSync cables are supplied; additional cables may be ordered:
2192-018	µSync cable - 18"
2192-036	µSync cable - 36"

**LIFETIME SUPPORT**

Mercury offers worldwide customers shorter development time, reliable, rugged solutions for a variety of environments, reduced costs, and mature software development tools. We offer free lifetime support for this product from our engineering staff, which customers can depend on through phone and email, as well as software updates. Take advantage of our 40 years of experience in delivering high-performance radar, communications, SIGINT, EW, and data acquisition MIL-Aero solutions worldwide.



**Corporate Headquarters**

50 Minuteman Road  
Andover, MA 01810 USA  
**+1 978.967.1401** tel  
**+1 866.627.6951** tel  
**+1 978.256.3599** fax

**International Headquarters**

**Mercury International**  
Avenue Eugène-Lance, 38  
PO Box 584  
CH-1212 Grand-Lancy 1  
Geneva, Switzerland  
**+41 22 884 5100** tel

**Learn more**

**Visit:** [mrcy.com/go/MP5292](http://mrcy.com/go/MP5292)

**For technical details, contact:**  
[mrcy.com/go/CF5292](http://mrcy.com/go/CF5292)



The Mercury Systems logo and the following are trademarks or registered trademarks of Mercury Systems, Inc.: Mercury Systems, Innovation That Matters, Flexor, Jade, Cobalt, Onyx, GateFlow, ReadyFlow, and Navigator. Other marks used herein may be trademarks or registered trademarks of their respective holders. Mercury believes this information is accurate as of its publication date and is not responsible for any inadvertent errors. The information contained herein is subject to change without notice.

