

AM3064 – Filter Bank

Digitally Tunable 1.0 to 6.5 GHz Bandpass

Description

AM3064 is a miniature filter IC containing digitally tunable bandpass filters covering the 1.0 GHz to 6.5 GHz frequency range. Separate low-pass and high-pass control lines provide independent control of both center frequency and bandwidth. Power and Control lines are internally filtered using Atlanta Micro’s AM35 filter chip. AM3064 provides an excellent filtering solution for a receiver or transceiver requiring flexible center frequency and bandwidth, high dynamic range, and small size, weight, and power consumption.

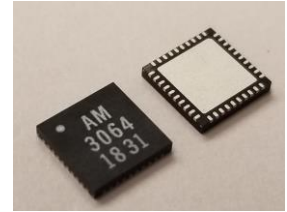

Features

- Digitally Tunable Bandpass Filters
- Independent LP and HP control
- 3.0 dB Insertion Loss
- +40 dBm Input IP3
- +3.3V to +5.0V Supply
- Integrated Power and Control Line Filtering (See AM35 Datasheet) 4-bit Control
- 6mm QFN Package
- -40C to +85C Operation

Functional Diagram

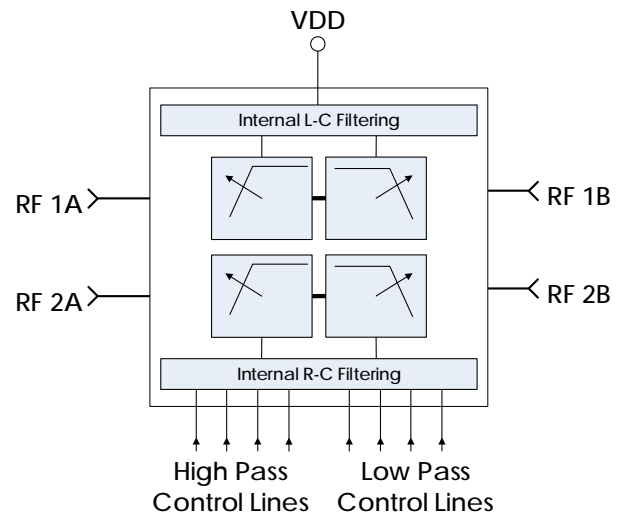

Characteristic Performance

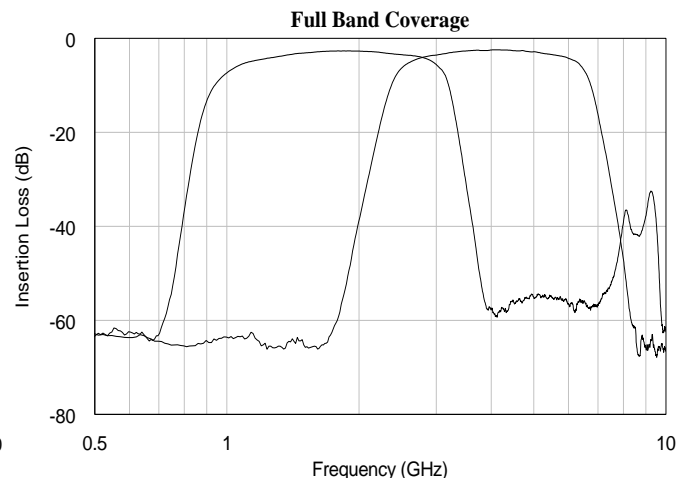
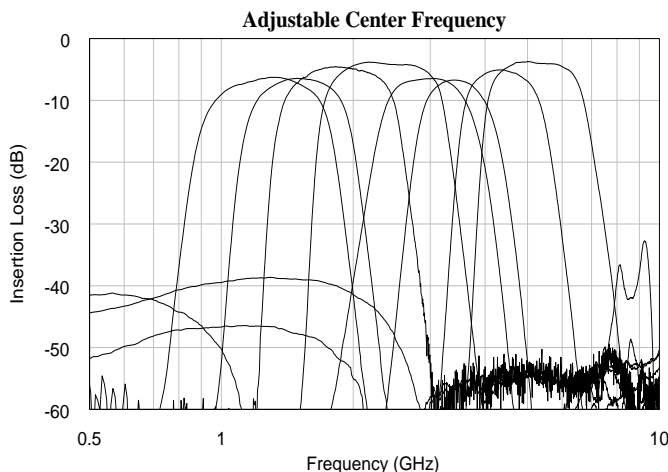

Table of Contents

Description	1	DC Electrical Characteristics.....	6
Features.....	1	RF Performance	6
Functional Diagram.....	1	Timing Characteristics	6
Characteristic Performance	1	State Tables.....	7
Revision History	2	Typical Performance	8
Pin Layout and Definitions.....	3	Typical Application.....	10
Specifications	5	Evaluation PC Board	11
Absolute Maximum Ratings.....	5	Related Parts.....	11
Handling Information.....	5	Component Compliance Information.....	12
Recommended Operating Conditions....	5		

Revision History

Date	Revision Number	Notes
August 17, 2018	1	Initial Release
July 17, 2019	2	Various Notes Added, Component Footprint Updated, Various Performance Details Added.
July 28, 2020	3	Moved Package Information to Main Product Details Page on Website

AM3064 – Filter Bank

Digitally Tunable 1.0 to 6.5 GHz Bandpass

Pin Layout and Definitions

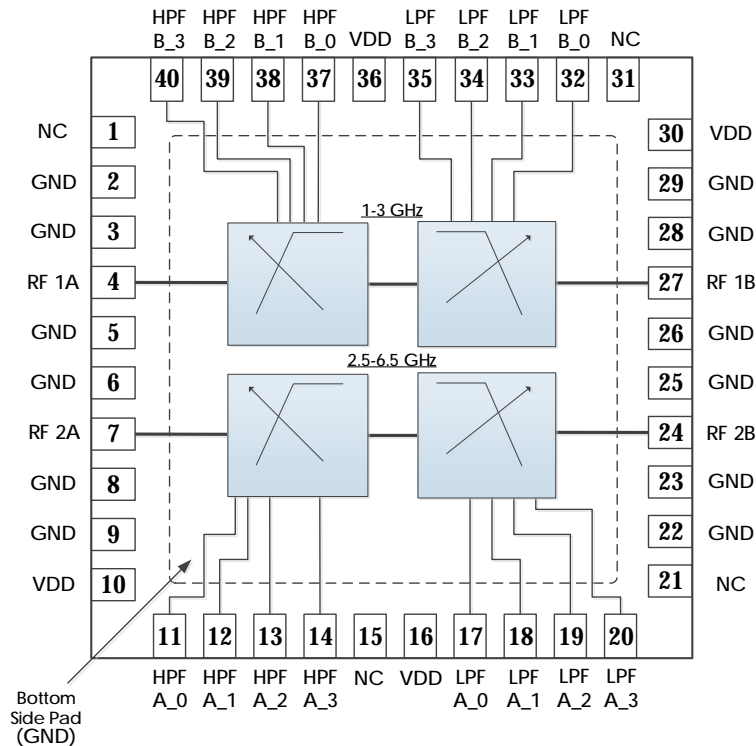

Pin Number	Pin Name	Pin Function
1	NC	Do Not Connect
2,3	GND	Ground – Common
4	RF1A	1.0-3.0 GHz RF Port 1 – 50 ohms – DC coupled – DC blocking capacitor required*
5,6	GND	Ground – Common
7	RF2A	2.5-6.5 GHz RF Port 1 – 50 ohms – DC coupled – DC blocking capacitor required*
8,9	GND	Ground – Common
10	VDD	DC Supply
11	HPFA_0	2.5-6.5 GHz HPF control bit 0
12	HPFA_1	2.5-6.5 GHz HPF control bit 1
13	HPFA_2	2.5-6.5 GHz HPF control bit 2
14	HPFA_3	2.5-6.5 GHz HPF control bit 3
15	NC	Do Not Connect
16	VDD	DC Supply
17	LPFA_0	2.5-6.5 GHz LPF control bit 0
18	LPFA_1	2.5-6.5 GHz LPF control bit 1
19	LPFA_2	2.5-6.5 GHz LPF control bit 2
20	LPFA_3	2.5-6.5 GHz LPF control bit 3
21	NC	Do Not Connect

*Note: DC blocking caps not required if in series with other Atlanta Micro parts of the same reference voltage.

AM3064 – Filter Bank

Digitally Tunable 1.0 to 6.5 GHz Bandpass

Pin Layout and Definitions (continued)

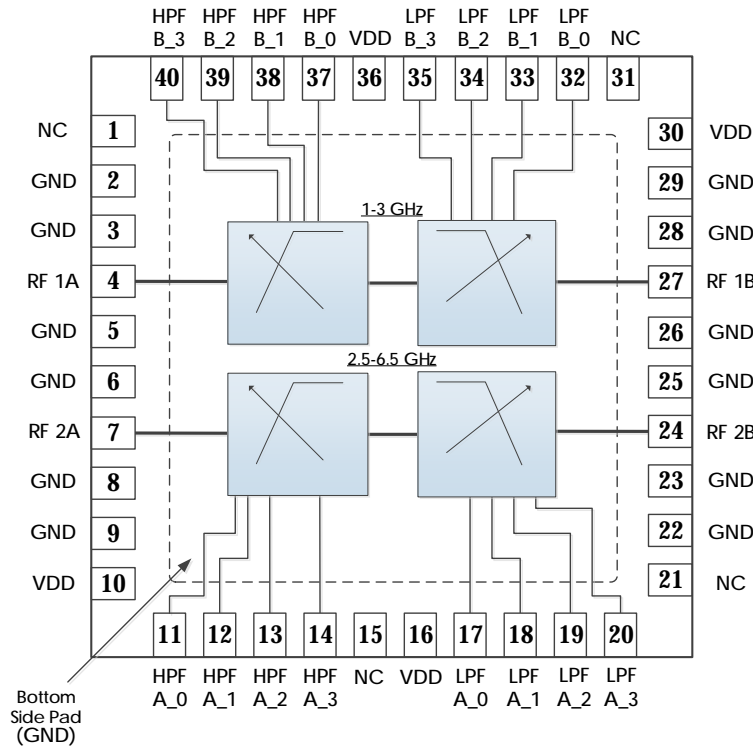

Pin Number	Pin Name	Pin Function
22,23	GND	Ground – Common
24	RF2B	2.5-6.5 GHz RF Port 2 – 50 ohms – DC coupled – DC blocking capacitor required*
25,26	GND	Ground – Common
27	RF1B	1.0-3.0 GHz RF Port 2 – 50 ohms – DC coupled – DC blocking capacitor required*
28,29	GND	Ground - Common
30	VDD	DC Supply
31	NC	Do Not Connect
32	LPFB_0	1.0-3.0 GHz LPF control bit 0
33	LPFB_1	1.0-3.0 GHz LPF control bit 1
34	LPFB_2	1.0-3.0 GHz LPF control bit 2
35	LPFB_3	1.0-3.0 GHz LPF control bit 3
36	VDD	DC Supply
37	HPFB_0	1.0-3.0 GHz HPF control bit 0
38	HPFB_1	1.0-3.0 GHz HPF control bit 1
39	HPFB_2	1.0-3.0 GHz HPF control bit 2
40	HPFB_3	1.0-3.0 GHz HPF control bit 3
Case GND	GND	Ground - Common

*Note: DC blocking caps not required if in series with other Atlanta Micro parts of the same reference voltage.

AM3064 – Filter Bank



Digitally Tunable 1.0 to 6.5 GHz Bandpass

Specifications

Absolute Maximum Ratings

	Minimum	Maximum
Supply Input Voltage	-0.3 V	+6.0 V
RF Input Power		+27dBm
Operating Junction Temperature	-40 C	+150 C
Storage Temperature Range	-50 C	+150 C

Note: Any device operation beyond the Absolute Maximum Ratings may result in permanent damage to the device. The values listed in this table are extremes and do not imply functional operation of the device at these or any other conditions beyond what is listed under Recommended Operating Conditions. Any part subjected to conditions outside of what is recommended for an extended amount of time may suffer from reliability concerns.

Handling Information

	Minimum	Maximum
Storage Temperature Range (Recommended)	-50 C	+125 C
Moisture Sensitivity Level	MSL 3	



Atlanta Micro products are electrostatic sensitive.
Follow safe handling practices to avoid damage

Recommended Operating Conditions

	Minimum	Typical	Maximum
Supply Voltage	+2.7 V	+5.0	
Operating Case Temperature	-40 C		+85 C
Operating Junction Temperature	-40 C		+125 C

AM3064 – Filter Bank



Digitally Tunable 1.0 to 6.5 GHz Bandpass

DC Electrical Characteristics

Parameter	Testing Conditions	Minimum	Typical	Maximum
DC Supply Voltage		+2.7 V	+5.0 V	
DC Supply Current	VDD = +3.3 V	<1 mA		3 mA
	VDD = +5.0 V	<1 mA		5 mA
Power Dissipated	VDD = +3.3 V	<3.3 mW		10 mW
	VDD = +5.0 V	<5 mW		25 mW
Logic Level Low		-0.1 V		+0.5 V
Logic Level High		+2.0 V		+VDD V

*Power and Control lines are internally filtered. See AM35 datasheet for performance details.

RF Performance

Parameter	Testing Conditions	Minimum	Typical	Maximum
Frequency Range		1.0 GHz		6.5 GHz
Insertion Loss			3.0 dB	
Return Loss			15.0 dB	
Input IP3			+40 dBm	

Timing Characteristics

Parameter	Minimum	Typical	Maximum
Switching Speed		1 μ s	

AM3064 – Filter Bank

Digitally Tunable 1.0 to 6.5 GHz Bandpass

State Tables

High Pass Filter Typical Cutoff Frequencies (GHz)

B_3/A_3	B_2/A_2	B_1/A_1	B_0/A_0	Band 1	Band 2
Low	Low	Low	Low	1.00	2.50
Low	Low	Low	High	1.01	2.53
Low	Low	High	Low	1.02	2.56
Low	Low	High	High	1.03	2.59
Low	High	Low	Low	1.06	2.61
Low	High	Low	High	1.08	2.64
Low	High	High	Low	1.10	2.70
Low	High	High	High	1.12	2.74
High	Low	Low	Low	1.14	2.85
High	Low	Low	High	1.16	2.93
High	Low	High	Low	1.20	3.06
High	Low	High	High	1.25	3.20
High	High	Low	Low	1.37	3.26
High	High	Low	High	1.47	3.47
High	High	High	Low	1.60	3.84
High	High	High	High	1.82	4.36

Low Pass Typical Cutoff Frequencies (GHz)

B_3/A_3	B_2/A_2	B_1/A_1	B_0/A_0	Band 1	Band 2
Low	Low	Low	Low	1.50	3.50
Low	Low	Low	High	1.55	3.60
Low	Low	High	Low	1.59	3.68
Low	Low	High	High	1.65	3.79
Low	High	Low	Low	1.70	3.89
Low	High	Low	High	1.78	4.04
Low	High	High	Low	1.84	4.15
Low	High	High	High	1.92	4.31
High	Low	Low	Low	2.00	4.54
High	Low	Low	High	2.10	4.74
High	Low	High	Low	2.20	4.97
High	Low	High	High	2.33	5.22
High	High	Low	Low	2.49	5.47
High	High	Low	High	2.67	5.84
High	High	High	Low	2.86	6.22
High	High	High	High	3.12	6.75

AM3064 – Filter Bank

Digitally Tunable 1.0 to 6.5 GHz Bandpass



Typical Performance

*Note: Only some states shown for simplicity

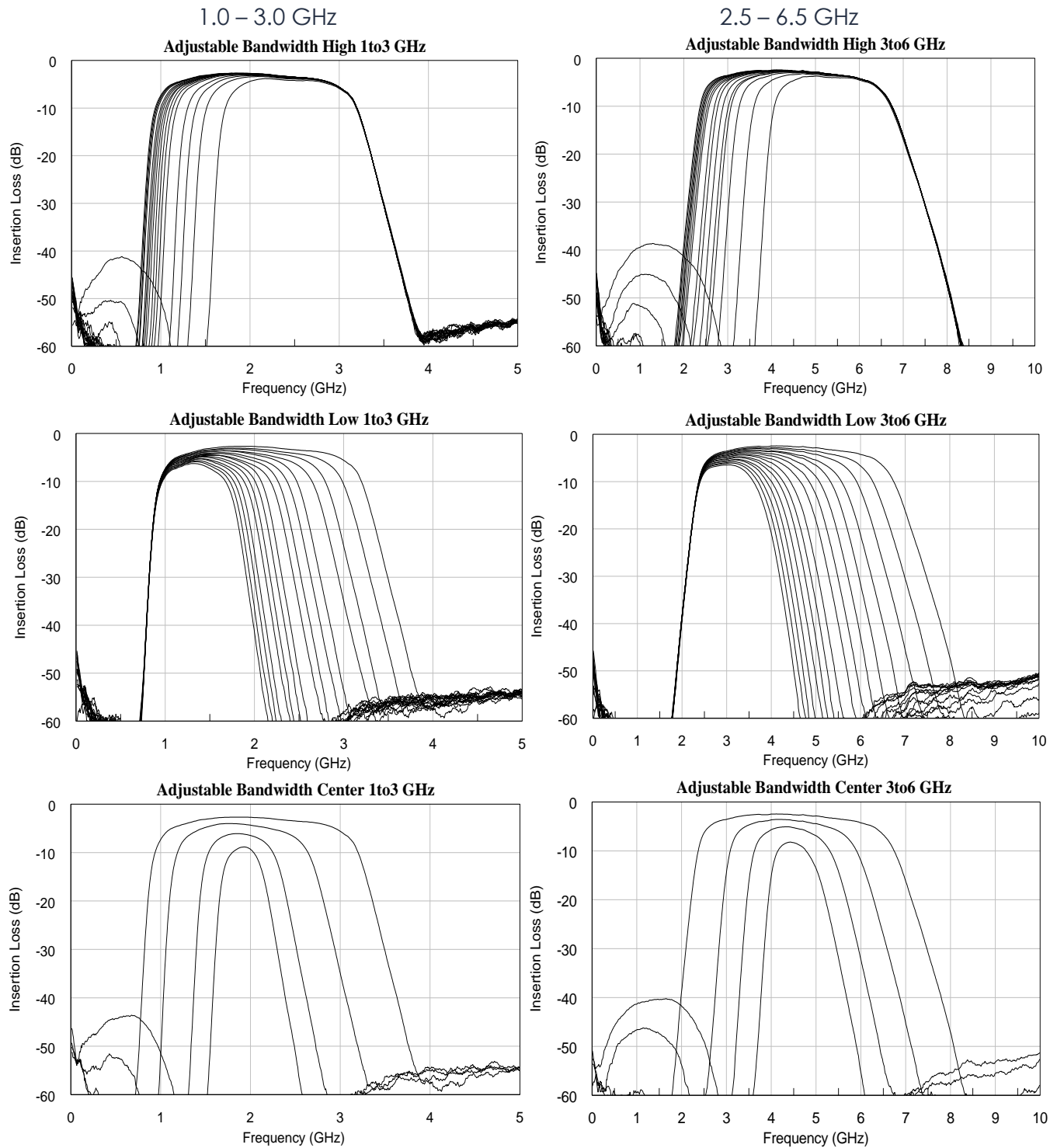

To obtain price, delivery, or to place an order contact MMICSales@mrcty.com
Atlanta Micro Inc., 3720 Davinci Ct, Suite 125, Norcross, GA 30092 • Phone: (470) 253-7640 • www.atlantamicro.com

AM3064 – Filter Bank

Digitally Tunable 1.0 to 6.5 GHz Bandpass



Typical Performance (continued)

*Note: Only some states shown for simplicity

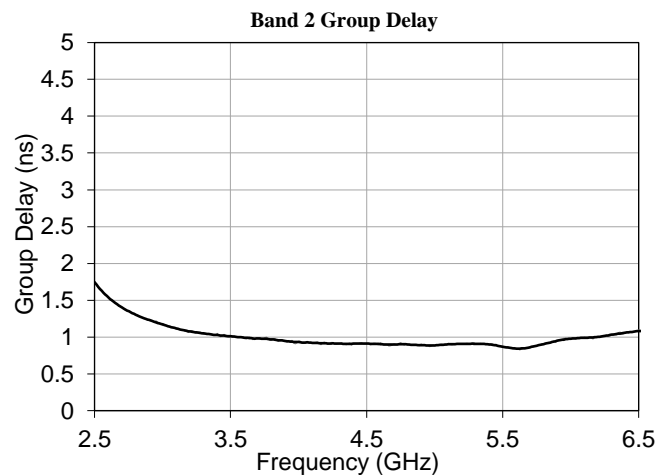
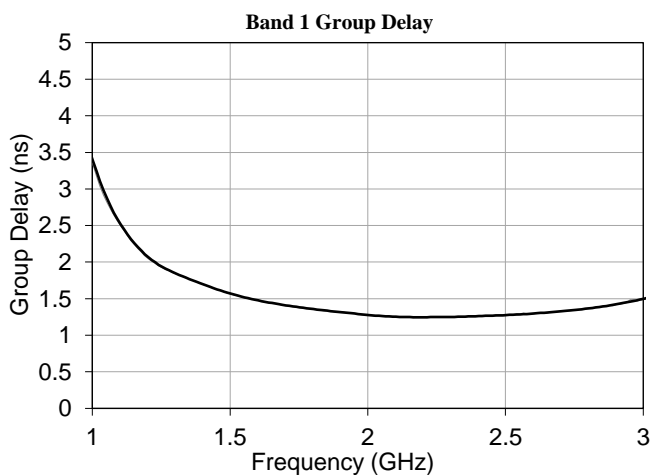
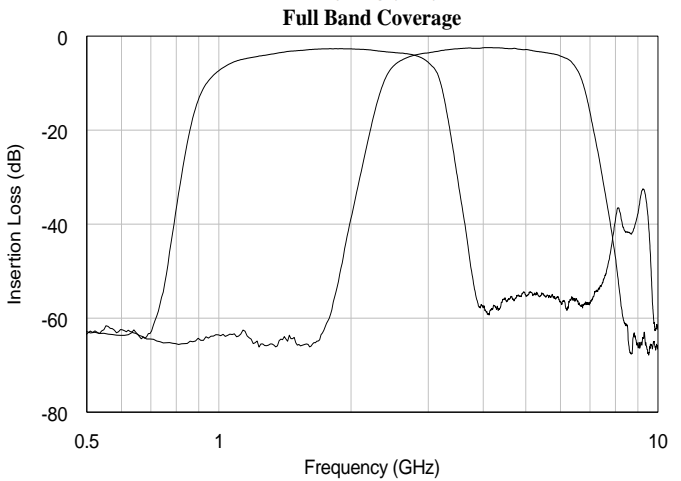
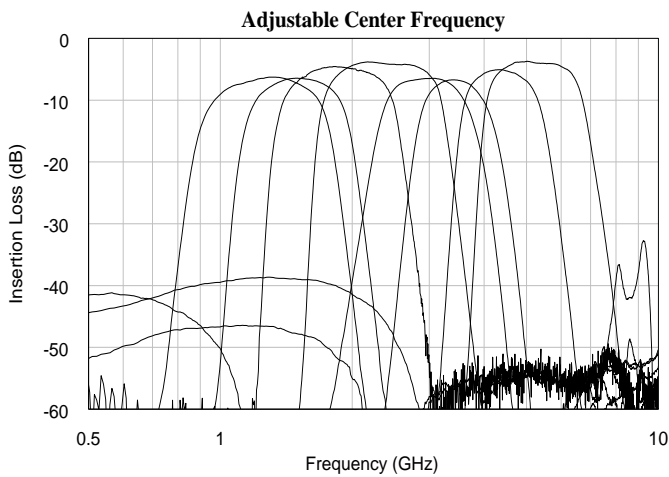
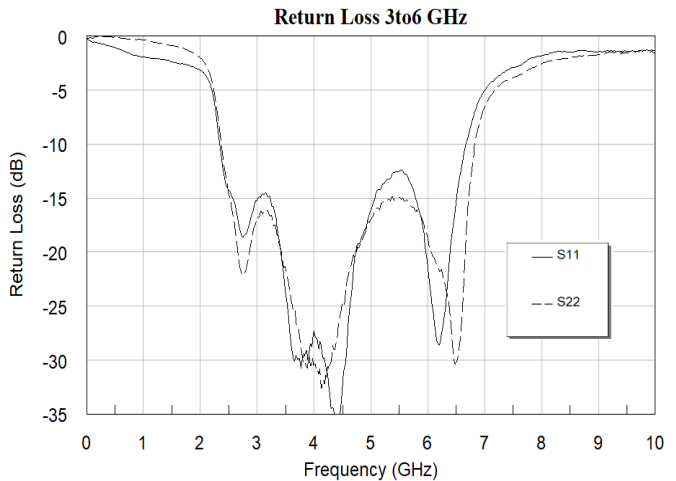
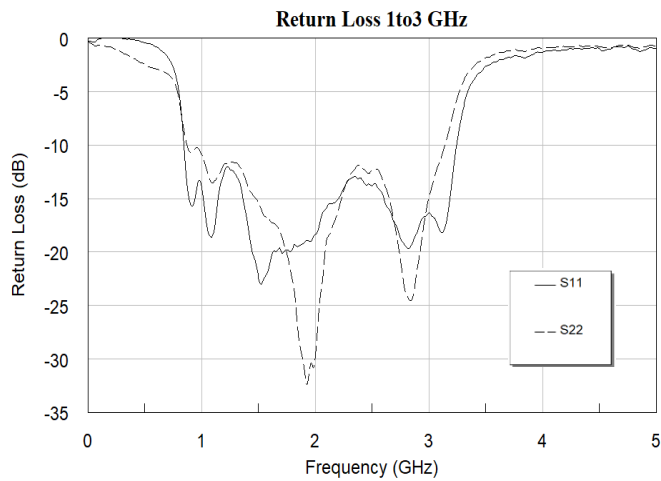

AM3064 – Filter Bank



Digitally Tunable 1.0 to 6.5 GHz Bandpass

Typical Application

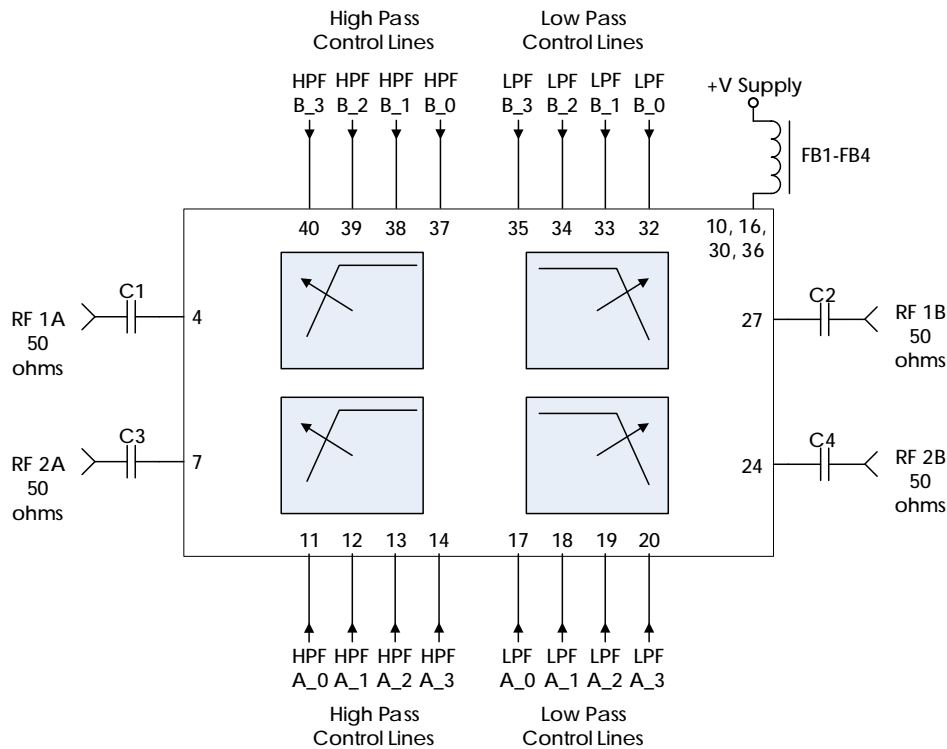

Recommended Component List (or equivalent):

Part	Value	Part Number	Manufacturer
C1 – C4	0.1 μ F	0201BB104KW160	Passive Plus
FB1 – FB4	-	MMZ1005A222E	TDK

Notes:

1. RF blocking capacitors should be high performance, low loss, broadband capacitors for optimum performance.
2. VDD and control lines filtered internally providing high frequency isolation up to 50+ GHz.
 - a. No additional RC filtering required on control lines.
 - b. Ferrite bead recommended on VDD lines for better low frequency performance.
 - c. See AM35 datasheet for performance details

AM3064 – Filter Bank

Digitally Tunable 1.0 to 6.5 GHz Bandpass

Evaluation PC Board

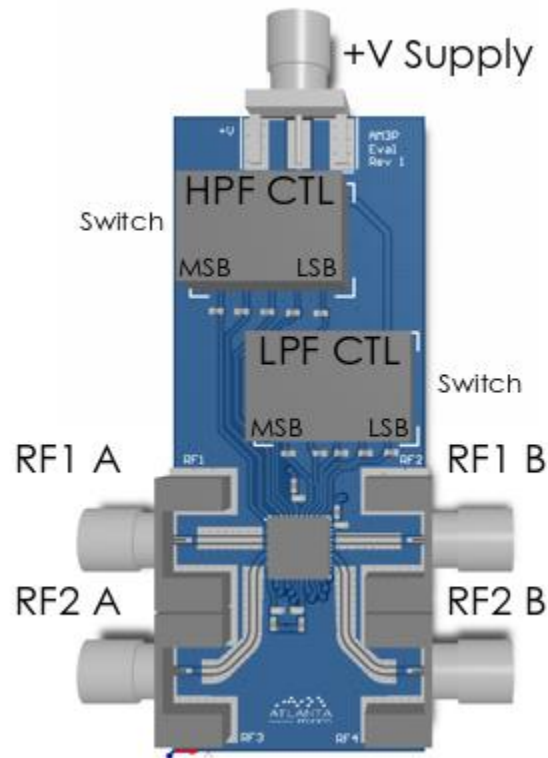

Related Parts

Part Number	Description			
AM3060	0.32 GHz	to	6.5 GHz	Switched Digitally Tunable BPF Bank
AM3063	6 GHz	to	18 GHz	Digitally Tunable Bandpass Filter Bank
AM3065	6 GHz	to	12 GHz	Digitally Tunable Bandpass Filter
AM3066	12 GHz	to	26.5 GHz	Digitally Tunable Bandpass Filter Bank
AM3089	2 GHz	to	18 GHz	Switched Analog Tunable BPF Bank
AM3134	2 GHz	to	4.5 GHz	Analog Tunable Bandpass Filter Bank
AM3135	3.5 GHz	to	9 GHz	Analog Tunable Bandpass Filter Bank
AM3136	8 GHz	to	19 GHz	Analog Tunable Bandpass Filter Bank
AM35	100 MHz	to	40 GHz	Power and Control EMI Filter Bank

Component Compliance Information

RoHS: Atlanta Micro, Inc. hereby certifies that all products comply with the EC Directive 2011/65/EC on the Restriction of Hazardous Substances, commonly known as EU-RoHS 6 and 10. All products supplied by Atlanta Micro shall be compliant with the European Directive 2011/65/EC based on the following substance list.

Substance List	Allowable Maximum Concentration
Lead (Pb)	<1000 PPM (0.1% by weight)
Mercury (Hg)	<1000 PPM (0.1% by weight)
Cadmium (Cd)	<75 PPM (0.0075% by weight)
Hexavalent Chromium (CrVI)	<1000 PPM (0.1% by weight)
Polybrominated Biphenyls (PBB)	<1000 PPM (0.1% by weight)
Polybrominated Diphenyl ethers (PBDE)	<1000 PPM (0.1% by weight)
Decabromodiphenyl Deca BDE	<1000 PPM (0.1% by weight)
Bis (2-ethylhexyl) Phthalate (DEHP)	<1000 PPM (0.1% by weight)
Butyl Benzyl Phthalate (BBP)	<1000 PPM (0.1% by weight)
Dibutyl Phthalate (DBP)	<1000 PPM (0.1% by weight)
Diisobutyl Phthalate (DIBP)	<1000 PPM (0.1% by weight)

REACH: Atlanta Micro, Inc. neither uses nor intentionally adds any of the substances considered to be a Substance of Very High Concern (SVHC) as defined by the EU Regulation (EC) No. 1907-2006 on Registration, Evaluation, Authorization, and Restriction of Chemicals (REACH).

Conflict Materials: Atlanta Micro does not knowingly use materials that are sourced from the Democratic Republic of Congo (DRC) or any other known conflict regions. Atlanta Micro's supply chain is comprised of sources that are both environmentally and socially responsible. We periodically review this requirement with our vendors to ensure continued compliance.

Atlanta Micro takes its responsibility as a global partner seriously and will use due diligence within our supply chain to ensure all standards are met to the best of our knowledge.