

# AM3172 – RF Filter Bank

## Digitally Tunable 20 MHz to 8 GHz Bandpass

### Description

AM3172 is a tunable bandpass filter module covering 20 MHz to 8 GHz. The device contains the AM3150, AM3151, and AM3156 digitally tunable filter components in a connectorized, shielded module. Control interface is a 3-wire SPI (serial peripheral interface). The AM3172 is an excellent front-end preselector for a receiver, providing both low insertion loss and valuable flexibility for tuning center frequency and bandwidth.



### Features

- Digitally Tunable Bandpass Filter
- 20 MHz to 8 GHz Frequency Range
- Independent Highpass/Lowpass Filter Control
- SPI Control Interface (16-Bit)
- 3 to 5 dB Insertion Loss
- +5.0V Supply
- +24dBm Power Handling
- 2.4" X 2.1" X 0.65" Shielded Module
- 3.6oz / 100g Product Weight
- -40C to +85C Operation

### Functional Diagram

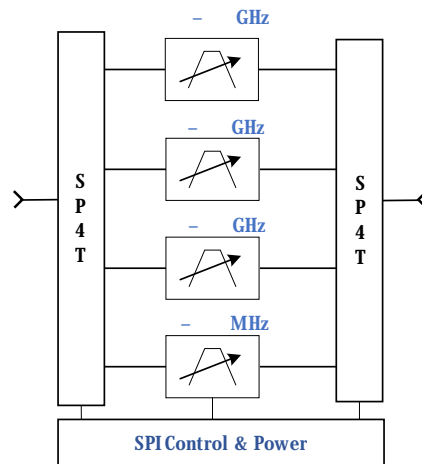

### Characteristic Performance

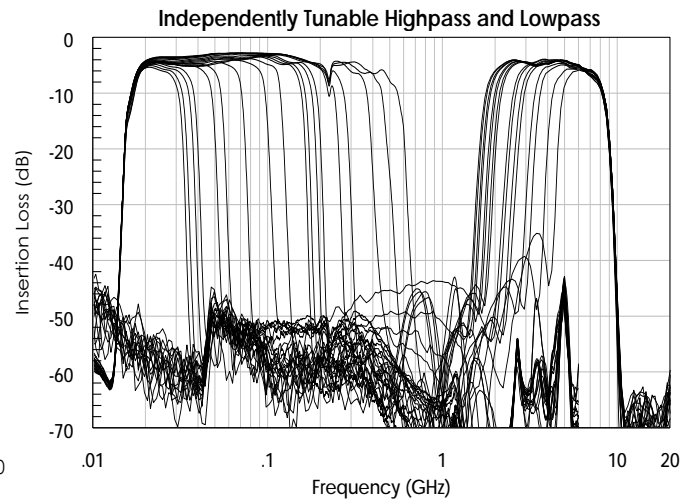
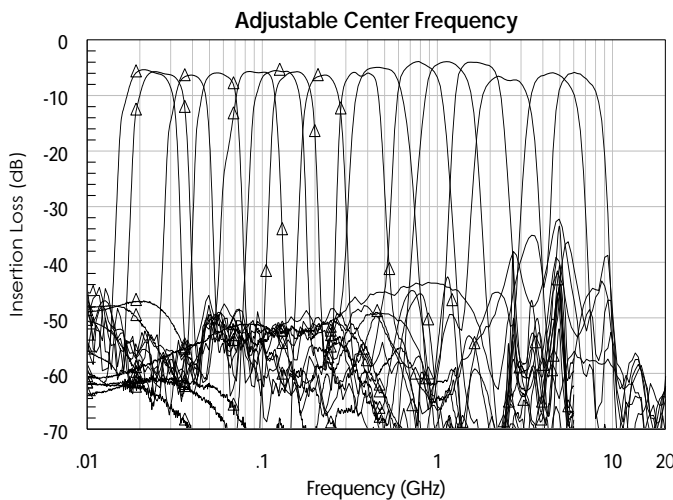

### Table of Contents

Description .....	1	DC Electrical Characteristics .....	5
Features .....	1	RF Performance .....	5
Functional Diagram .....	1	Timing Characteristics .....	5
Characteristic Performance .....	1	<b>Control Details</b> .....	<b>6</b>
Revision History .....	2	State Table .....	6
Control and Power Interface .....	3	Typical Performance .....	9
Specifications .....	4	<b>Mechanical Outline</b> .....	<b>11</b>
Absolute Maximum Ratings .....	4	<b>Related Parts</b> .....	<b>11</b>
Handling Information .....	4	<b>Component Compliance Information</b> .....	<b>12</b>

### Revision History

Date	Revision Number	Notes
July 8, 2022	1	Preliminary Release

# AM3172 – RF Filter Bank



Digitally Tunable 20 MHz to 8 GHz Bandpass

## Control and Power Interface

(TE Connectivity 5-103634-7, 0.100" pitch header)

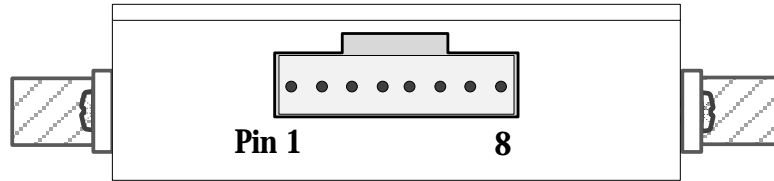

Pin Number	Pin Name	Pin Function
1	#Reset	Shift Register Master Reset, Active Low (internal 10k pullup)
2	Clock	Shift Register Clock
3	Strobe	Storage Register latch enable (low-to-high transition)
4	#OE	Shift Register Output Enable, Active Low (internal 10k pull down)
5	Data	Shift Register Serial Data In (on rising clock edge)
6	GND	Ground
7	Vdd	DC supply voltage
8	Vdd	DC supply voltage (+5.0V nominal)

Mating connector is TE Connectivity 5-103961-7, with 24 to 26 AWG wire

# AM3172 – RF Filter Bank



Digitally Tunable 20 MHz to 8 GHz Bandpass

## Specifications

### Absolute Maximum Ratings

	Minimum	Maximum
Supply Voltage	-0.3 V	+6.0 V
RF Input Power		+27 dBm
Operating Case Temperature	-40 C	+85 C
Storage Temperature Range	-55 C	+125 C

**Note:** Any device operation beyond the Absolute Maximum Ratings may result in permanent damage to the device. The values listed in this table are extremes and do not imply functional operation of the device at these or any other conditions beyond what is listed under Recommended Operating Conditions. Any part subjected to conditions outside of what is recommended for an extended amount of time may suffer from reliability concerns.

### Handling Information

	Minimum	Maximum
ESD classification (HBM)	1A	
Moisture Sensitivity Level	MSL 3	



Atlanta Micro products are electrostatic sensitive.  
Follow safe handling practices to avoid damage

# AM3172 – RF Filter Bank

## Digitally Tunable 20 MHz to 8 GHz Bandpass

### DC Electrical Characteristics

(T = 25 °C unless otherwise specified)

Parameter	Testing Conditions	Minimum	Typical	Maximum
DC Supply Voltage		+4.7 V	+5.0 V	+5.3 V
DC Supply Current	VDD = +5.0 V		20 mA	
Power Dissipated	VDD = +5.0 V		100 mW	
Logic Level Low		-0.1 V		0.3*VDD
Logic Level High		0.7*VDD		+VDD

### RF Performance

(T = 25 °C unless otherwise specified)

Parameter	Testing Conditions	Minimum	Typical	Maximum
Frequency Range				
	Band 1	20 MHz		500 MHz
	Band 2	400 MHz		1.2 GHz
	Band 3	1 GHz		2.5 GHz
	Band 4	2.0 GHz		8.0 GHz
Insertion Loss	Band 1		-5 dB	
	Band 2		-4 dB	
	Band 3		-4 dB	
	Band 4		-6 dB	
Return Loss			-12 dB	
Input P1dB			+24 dBm	

### Timing Characteristics

Parameter	Minimum	Typical	Maximum
Band Switching Speed		1 $\mu$ s	
SPI Clock Rate			50 MHz

Note: Timing characteristics measured from receipt of 16-bit control message to 90% RF amplitude

# AM3172 – RF Filter Bank

## Digitally Tunable 20 MHz to 8 GHz Bandpass

### Control Details

The AM3172 is controlled over a serial peripheral interface. The command structure is based upon a 16-bit word, with data transferred on rising edge of clock and MSB first.

#### Timing diagram

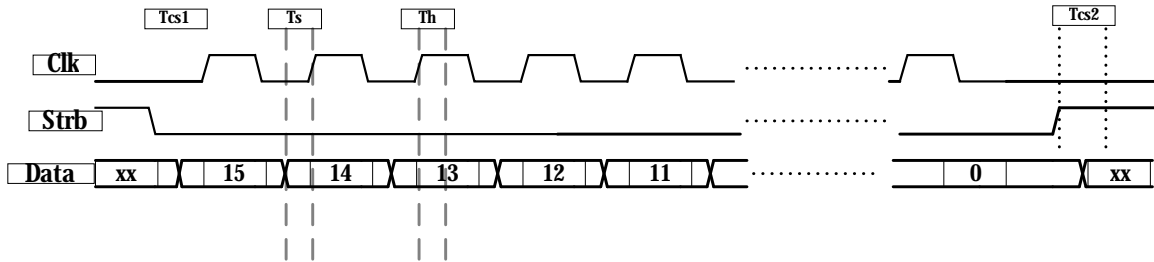

Bit	Name	Description
15 (MSB)	N/C	unused
14	N/C	unused
13	N/C	unused
12	N/C	unused
11	VL1	Lowpass Filter Control 1
10	VL2	Lowpass Filter Control 2
9	VL3	Lowpass Filter Control 3
8	VL4	Lowpass Filter Control 4
7	VL5	Lowpass Filter Control 5
6	VSW2	SP4T Switch Control 2
5	VSW1	SP4T Switch Control 1
4	VH1	Highpass Filter Control 1
3	VH2	Highpass Filter Control 2
2	VH3	Highpass Filter Control 3
1	VH4	Highpass Filter Control 4
0 (LSB)	VH5	Highpass Filter Control 5

#### State Table

VSW2	VSW1	Filter Band
Low	Low	Band 1 – 20 to 500 MHz
Low	High	Band 2 – 0.4 to 1.25 GHz
High	Low	Band 3 – 1.0 to 2.5 GHz
High	High	Band 4 – 2.0 to 8.0 GHz

# AM3172 – RF Filter Bank



## Digitally Tunable 20 MHz to 8 GHz Bandpass

### State Table (continued)

#### High Pass Filter Typical Cutoff Frequencies (GHz)

VH5	VH4	VH3	VH2	VH1	Band 1	Band 2	Band 3	Band 4
L	L	L	L	L	.100	0.4	0.94	2.0
L	L	L	L	H	.100	0.41	0.95	2.01
L	L	L	H	L	.103	0.42	0.97	2.07
L	L	L	H	H	.105	0.43	0.98	2.09
L	L	H	L	L	.121	0.45	1.0	2.19
L	L	H	L	H	.124	0.47	1.03	2.21
L	L	H	H	L	.131	0.49	1.06	2.3
L	L	H	H	H	.136	0.50	1.09	2.35
L	H	L	L	L	.193	0.51	1.17	2.77
L	H	L	L	H	.196	0.53	1.18	2.85
L	H	L	H	L	.209	0.56	1.21	3.06
L	H	L	H	H	.215	0.6	1.25	3.18
L	H	H	L	L	.260	0.64	1.37	3.63
L	H	H	L	H	.272	0.69	1.4	3.88
L	H	H	H	L	.316	0.76	1.47	4.65
L	H	H	H	H	.355	0.85	1.56	5.19
H	L	L	L	L	.019	0.4	0.94	2.0
H	L	L	L	H	.019	0.41	0.95	2.01
H	L	L	H	L	.020	0.42	0.97	2.07
H	L	L	H	H	.020	0.43	0.98	2.09
H	L	H	L	L	.023	0.45	1.0	2.19
H	L	H	L	H	.023	0.47	1.03	2.21
H	L	H	H	L	.024	0.49	1.06	2.3
H	L	H	H	H	.025	0.50	1.09	2.35
H	H	L	L	L	.035	0.51	1.17	2.77
H	H	L	L	H	.036	0.53	1.18	2.85
H	H	L	H	L	.038	0.56	1.21	3.06
H	H	L	H	H	.039	0.6	1.25	3.18
H	H	H	L	L	.050	0.64	1.37	3.63
H	H	H	L	H	.053	0.69	1.4	3.88
H	H	H	H	L	.064	0.76	1.47	4.65
H	H	H	H	H	.076	0.85	1.56	5.19

Note: State Table cutoff frequencies measured with VDD = 5.0V

# AM3172 – RF Filter Bank



## Digitally Tunable 20 MHz to 8 GHz Bandpass

### State Table (continued)

#### Low Pass Filter Typical Cutoff Frequencies (GHz)

VL5	VL4	VL3	VL2	VL1	Band 1	Band 2	Band 3	Band 4
L	L	L	L	L	.028	0.53	1.37	3.0
L	L	L	L	H	.029	0.54	1.41	3.02
L	L	L	H	L	.030	0.55	1.45	3.12
L	L	L	H	H	.031	0.56	1.47	3.2
L	L	H	L	L	.032	0.57	1.51	3.38
L	L	H	L	H	.033	0.59	1.53	3.47
L	L	H	H	L	.035	0.62	1.59	3.63
L	L	H	H	H	.036	0.66	1.64	3.76
L	H	L	L	L	.043	0.75	1.7	4.14
L	H	L	L	H	.046	0.78	1.79	4.31
L	H	L	H	L	.049	0.82	1.91	4.53
L	H	L	H	H	.053	0.87	1.98	4.76
L	H	H	L	L	.065	0.92	2.08	5.47
L	H	H	L	H	.073	1.02	2.15	5.95
L	H	H	H	L	.089	1.15	2.29	6.7
L	H	H	H	H	.112	1.25	2.4	8.0
H	L	L	L	L	.141	0.53	1.37	3.0
H	L	L	L	H	.145	0.54	1.41	3.02
H	L	L	H	L	.149	0.55	1.45	3.12
H	L	L	H	H	.153	0.56	1.47	3.2
H	L	H	L	L	.163	0.57	1.51	3.38
H	L	H	L	H	.168	0.59	1.53	3.47
H	L	H	H	L	.174	0.62	1.59	3.63
H	L	H	H	H	.180	0.66	1.64	3.76
H	H	L	L	L	.213	0.75	1.7	4.14
H	H	L	L	H	.224	0.78	1.79	4.31
H	H	L	H	L	.239	0.82	1.91	4.53
H	H	L	H	H	.254	0.87	1.98	4.76
H	H	H	L	L	.318	0.92	2.08	5.47
H	H	H	L	H	.357	1.02	2.15	5.95
H	H	H	H	L	.439	1.15	2.29	6.7
H	H	H	H	H	.550	1.25	2.4	8.0

Note: State Table cutoff frequencies measured with VDD = 5.0V



# AM3172 – RF Filter Bank

## Digitally Tunable 20 MHz to 8 GHz Bandpass

### Typical Performance

(V<sub>dd</sub> = 5V, T=25°C unless otherwise specified)

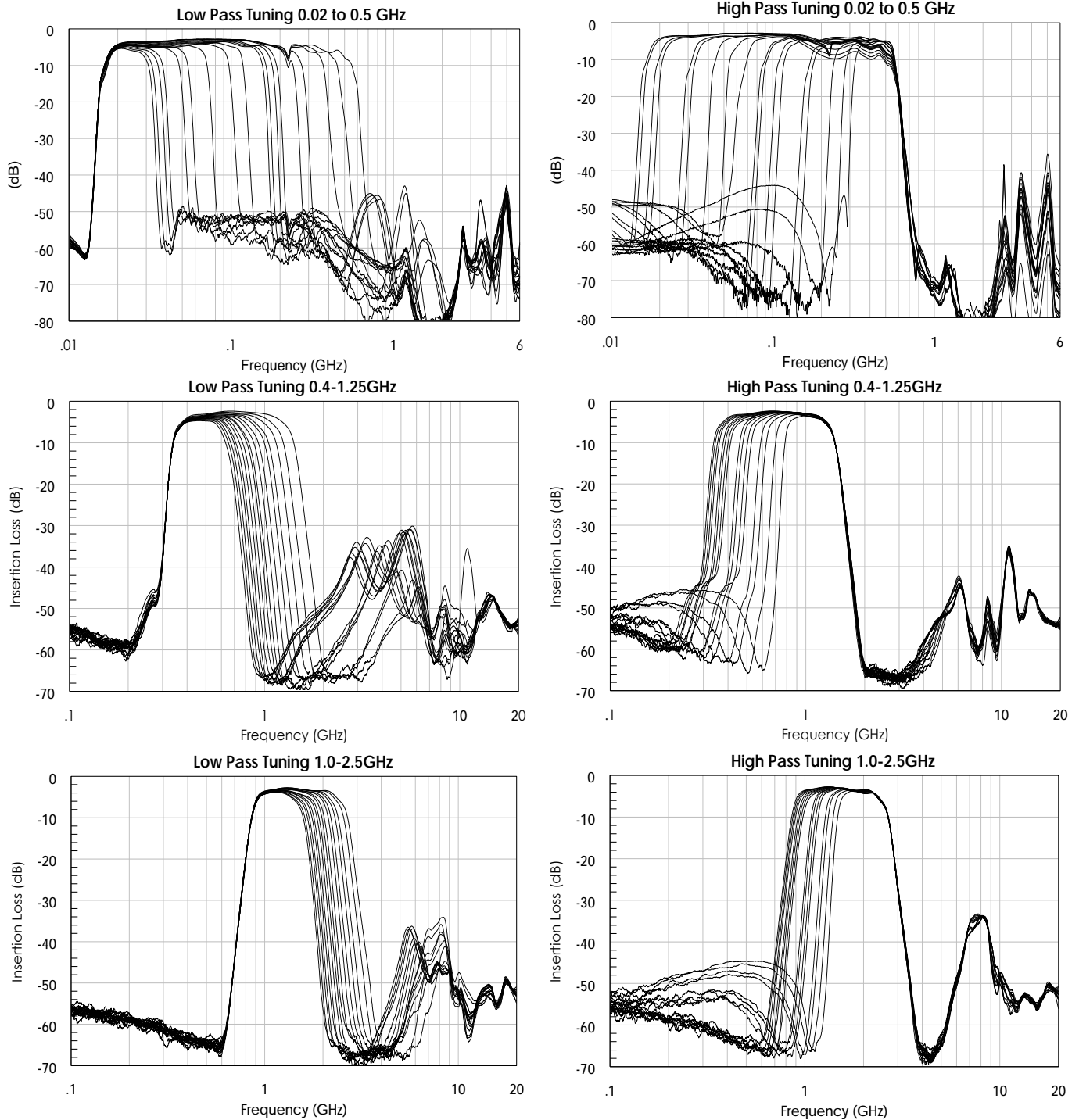

# AM3172 – RF Filter Bank

## Digitally Tunable 20 MHz to 8 GHz Bandpass

### Typical Performance (continued)

(V<sub>dd</sub> = 5V, T=25°C unless otherwise specified)

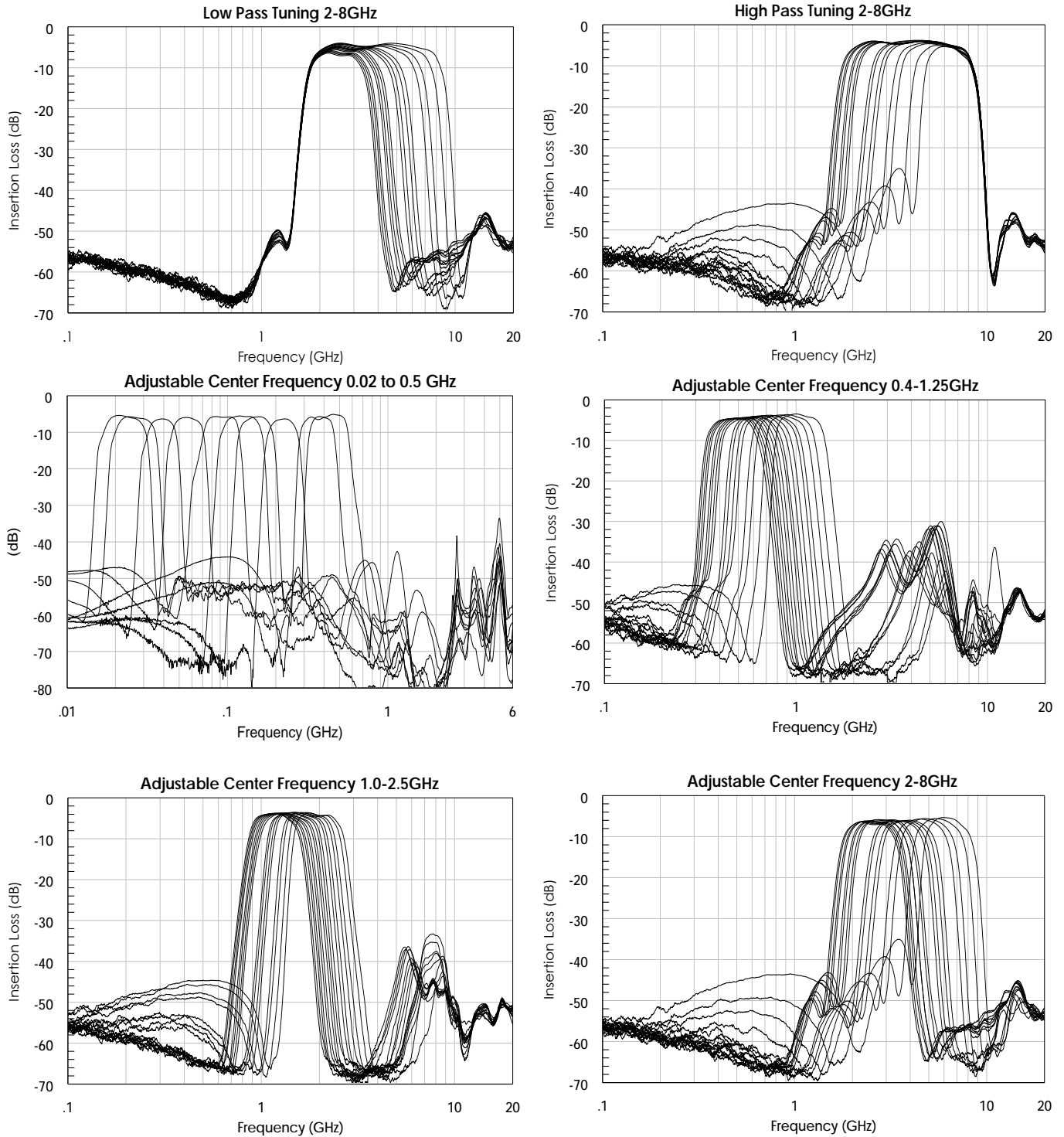

# AM3172 – RF Filter Bank



Digitally Tunable 20 MHz to 8 GHz Bandpass

## Mechanical Outline

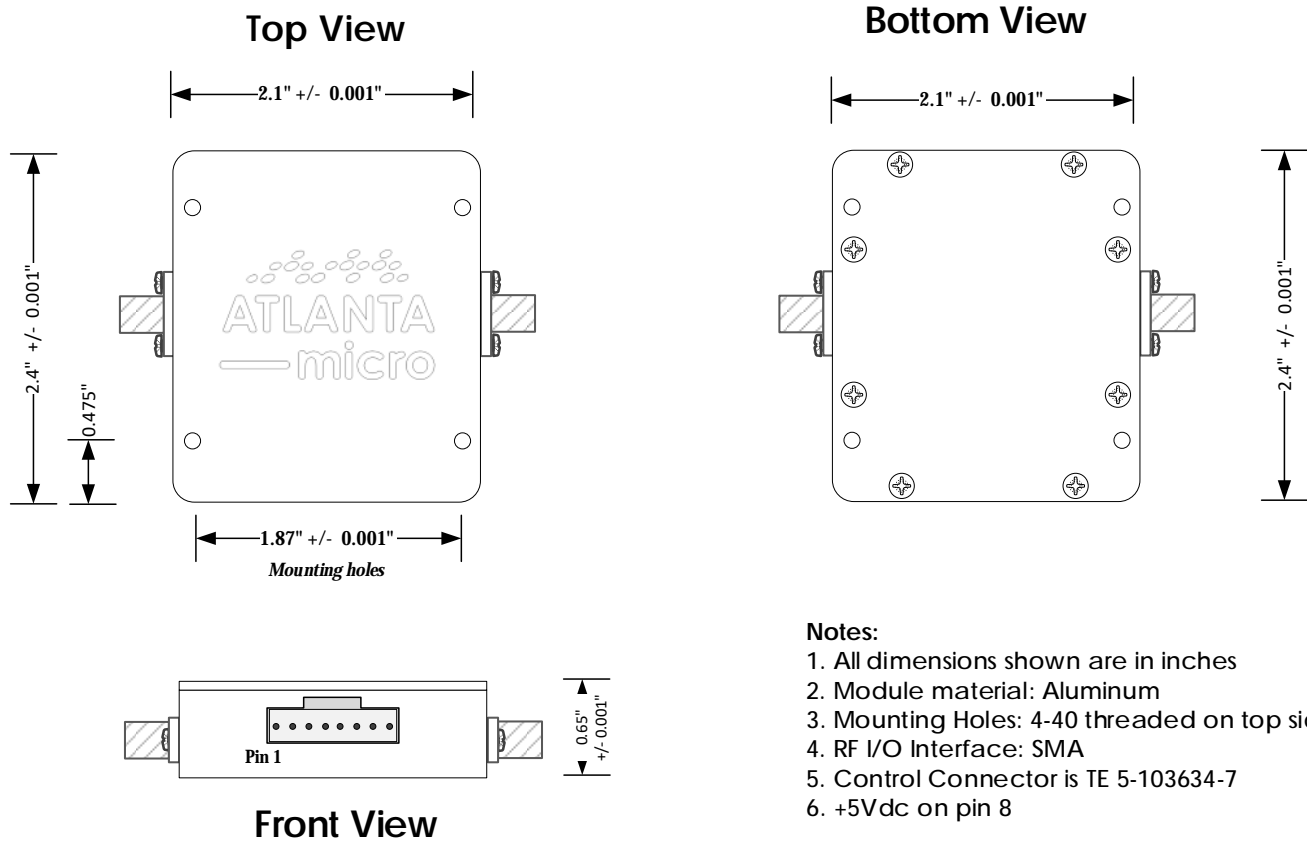

## Related Parts

Part Number	Description
AM3060	0.32 GHz to 6.5 GHz Digitally Tunable Bandpass Filter
AM3150	30 MHz to 550 MHz Digitally Tunable Low Pass Filter
AM3151	20 MHz to 360 MHz Digitally Tunable High Pass Filter
AM3156	400 MHz to 8 GHz Digitally Tunable Bandpass Filter

### Component Compliance Information

**REACH:** Atlanta Micro, Inc. neither uses nor intentionally adds any of the substances considered to be a Substance of Very High Concern (SVHC) as defined by the EU Regulation (EC) No. 1907-2006 on Registration, Evaluation, Authorization, and Restriction of Chemicals (REACH).

**Conflict Materials:** Atlanta Micro does not knowingly use materials that are sourced from the Democratic Republic of Congo (DRC) or any other known conflict regions. Atlanta Micro's supply chain is comprised of sources that are both environmentally and socially responsible. We periodically review this requirement with our vendors to ensure continued compliance.

Atlanta Micro takes its responsibility as a global partner seriously and will use due diligence within our supply chain to ensure all standards are met to the best of our knowledge.