

AM3108 – Filter Bank

Digitally Tunable 12.0 to 18.0 GHz Highpass

Description

AM3108 is a miniature digitally tunable highpass filter covering the 12.0 to 18.0 GHz frequency range. The filter provides 32 selectable highpass cutoff states with 5 digital control bits. The tunable lowpass filter can be combined with one of Atlanta Micro’s tunable lowpass filters to provide a flexible tunable bandpass filter solution. AM3108 has internal 50Ω matching, is packaged in a 4mm QFN package, and operates over the -40C to +85C temperature range.

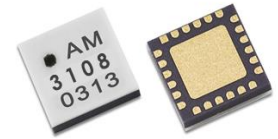

Features

- Discrete High Pass Cutoff Steps
- 5-bit Control, 3V or 5V Logic
- +3.3V to +5V DC Supply
- 5.0 dB AVG Insertion Loss
- +43 dBm Input IP3
- 4mm QFN Package
- -40C to +85C Operation
- No Calibration Required

Functional Diagram

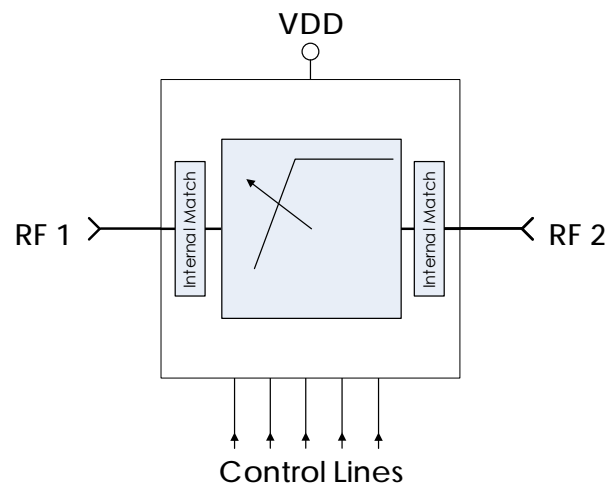

Characteristic Performance

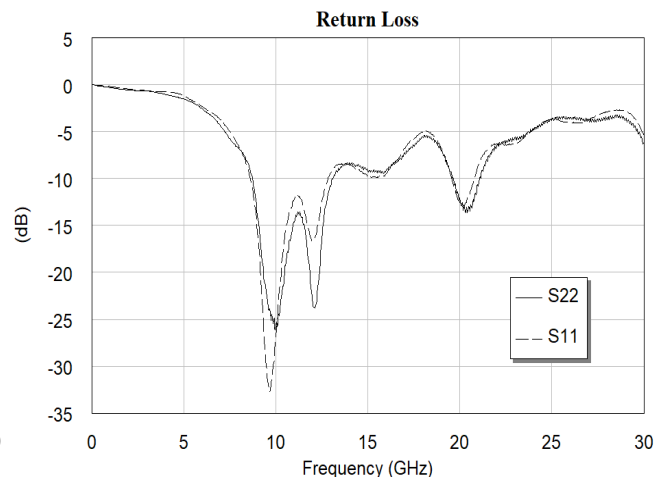
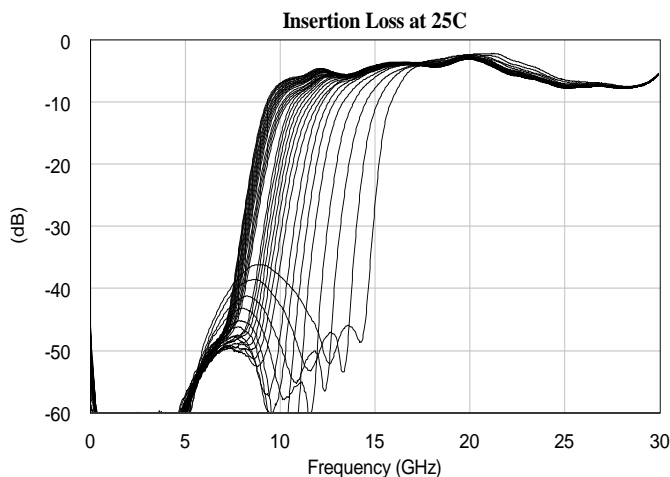

Table of Contents

Description	1	DC Electrical Characteristics.....	5
Features.....	1	RF Performance.....	5
Functional Diagram.....	1	Timing Characteristics	5
Characteristic Performance	1	State Table.....	6
Revision History	2	Typical Performance	7
Pin Layout and Definitions.....	3	Typical Application.....	8
Specifications	4	Package Details.....	9
Absolute Maximum Ratings.....	4	Evaluation PC Board	10
Handling Information.....	4	Related Parts.....	10
Recommended Operating Conditions ...	4	Component Compliance Information.....	11

Revision History

Date	Revision Number	Notes
August 24, 2018	1	Initial Release

Pin Layout and Definitions

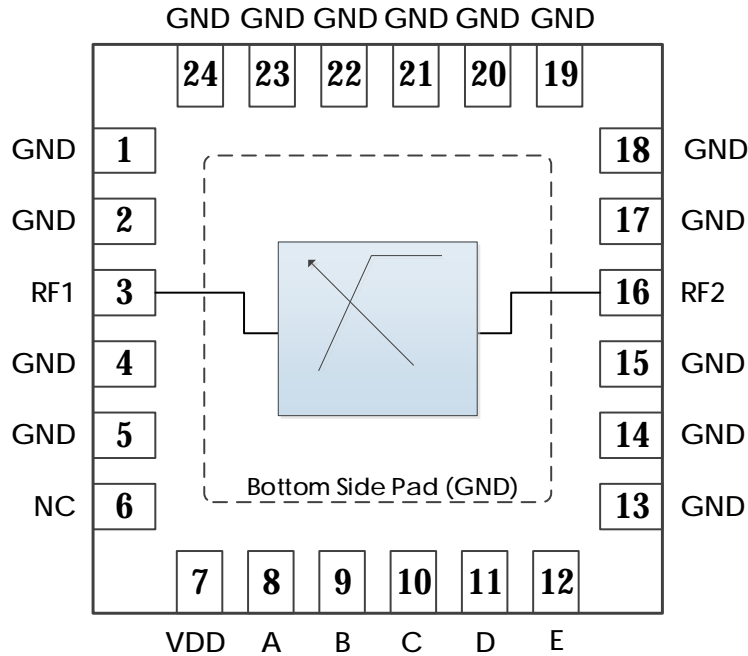

Pin Number	Pin Name	Pin Function
1,2	GND	Ground - Common
3	RF1	RF Port 1 – 50 ohms – DC coupled. External DC blocking capacitor required*
4,5	GND	Ground - Common
6	NC	Do Not Connect
7	VDD	DC Power Input
8	A	Control Bit A
9	B	Control Bit B
10	C	Control Bit C
11	D	Control Bit D
12	E	Control Bit E
13-15	GND	Ground - Common
16	RF2	RF Port 2 – 50 ohms – DC coupled. External DC blocking capacitor required*
17-24	GND	Ground - Common
Case GND	GND	Ground - Common

*Note: DC blocking caps not required if in series with other Atlanta Micro parts of the same reference voltage.

AM3108 – Filter Bank



Digitally Tunable 12.0 to 18.0 GHz Highpass

Specifications

Absolute Maximum Ratings

	Minimum	Maximum
Supply Voltage	-0.3 V	+6.0 V
RF Input Power		+27 dBm
Operating Junction Temperature	-40 C	+150 C
Storage Temperature Range	-50 C	+150 C

Note: Any device operation beyond the Absolute Maximum Ratings may result in permanent damage to the device. The values listed in this table are extremes and do not imply functional operation of the device at these or any other conditions beyond what is listed under Recommended Operating Conditions. Any part subjected to conditions outside of what is recommended for an extended amount of time may suffer from reliability concerns.

Handling Information

	Minimum	Maximum
Storage Temperature Range (Recommended)	-50 C	+125 C
Moisture Sensitivity Level	MSL 1	



Atlanta Micro products are electrostatic sensitive.
Follow safe handling practices to avoid damage

Recommended Operating Conditions

	Minimum	Typical	Maximum
Supply Voltage	+2.7 V	+5.0 V	
Operating Case Temperature	-40 C		+85 C
Operating Junction Temperature	-40 C		+125 C

AM3108 – Filter Bank

Digitally Tunable 12.0 to 18.0 GHz Highpass

DC Electrical Characteristics

(T = 25 °C unless otherwise specified)

Parameter	Testing Conditions	Minimum	Typical	Maximum
DC Supply Voltage		+2.7 V	+5.0 V	
DC Supply Current	VDD = +3.3 V	1 mA		2 mA
	VDD = +5.0 V	2 mA		3 mA
Power Dissipated	VDD = +3.3 V	3.3 mW		6.6 mW
	VDD = +5.0 V	10 mW		15 mW
Logic Level Low		-0.1 V		+0.5 V
Logic Level High		+2.0 V		+VDD

RF Performance

(T = 25 °C unless otherwise specified)

Parameter	Testing Conditions	Minimum	Typical	Maximum
Frequency Range		12.0 GHz		18.0 GHz
Insertion Loss	f=10 GHz, ABCDE=00000		6.9 dB	
	f=20 GHz, ABCDE=00000		2.8 dB	
	f=30 GHz, ABCDE=00000		5.4 dB	
Return Loss	f=10 GHz, ABCDE=00000		26.9 dB	
	f=20 GHz, ABCDE=00000		12.6 dB	
	f=30 GHz, ABCDE=00000		5.3 dB	
Input IP3	ABCDE=00000		+43 dBm	

Timing Characteristics

Parameter	Minimum	Typical	Maximum
Switching Speed		1 μ s	

AM3108 – Filter Bank



Digitally Tunable 12.0 to 18.0 GHz Highpass

State Table

Control Lines					Typical Cutoff Frequency (GHz)
E	D	C	B	A	
L	L	L	L	L	10.23
L	L	L	L	H	10.31
L	L	L	H	L	10.37
L	L	L	H	H	10.46
L	L	H	L	L	10.56
L	L	H	L	H	10.65
L	L	H	H	L	10.73
L	L	H	H	H	10.87
L	H	L	L	L	10.98
L	H	L	L	H	11.07
L	H	L	H	L	11.18
L	H	L	H	H	11.37
L	H	H	L	L	11.50
L	H	H	L	H	11.62
L	H	H	H	L	11.37
L	H	H	H	H	11.74
H	L	L	L	L	11.80
H	L	L	L	H	11.85
H	L	L	H	L	11.98
H	L	L	H	H	12.22
H	L	H	L	L	12.42
H	L	H	L	H	12.73
H	L	H	H	L	13.06
H	L	H	H	H	13.26
H	H	L	L	L	13.80
H	H	L	L	H	14.02
H	H	L	H	L	14.27
H	H	L	H	H	15.11
H	H	H	L	L	15.50
H	H	H	L	H	16.10
H	H	H	H	L	16.43
H	H	H	H	H	16.89

To obtain price, delivery, or to place an order contact MMICSales@rcy.com
Atlanta Micro Inc., 3720 Davinci Ct, Suite 125, Norcross, GA 30092 • Phone: (470) 253-7640 • www.atlantamicro.com

AM3108 – Filter Bank



Digitally Tunable 12.0 to 18.0 GHz Highpass

Typical Performance

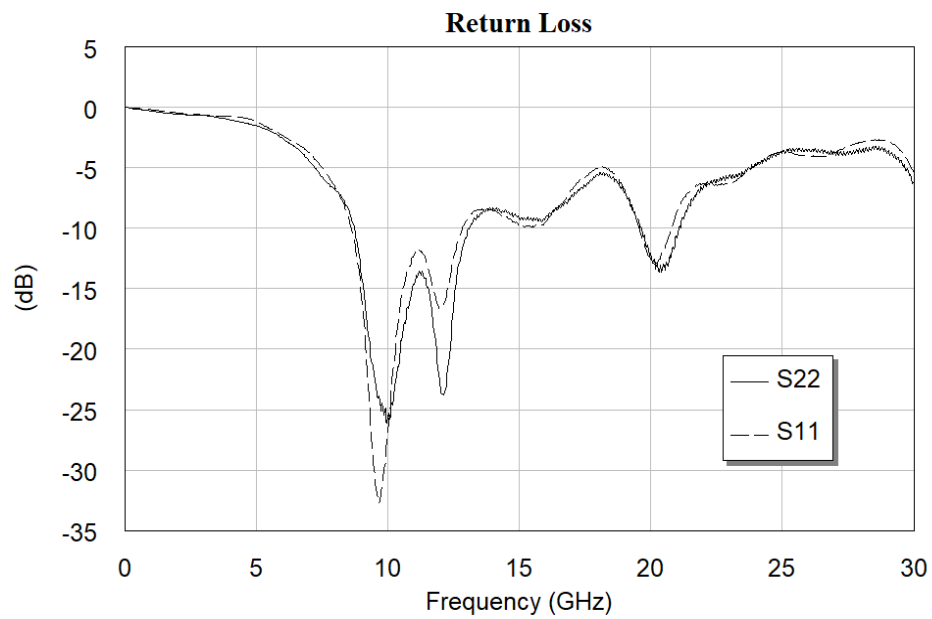
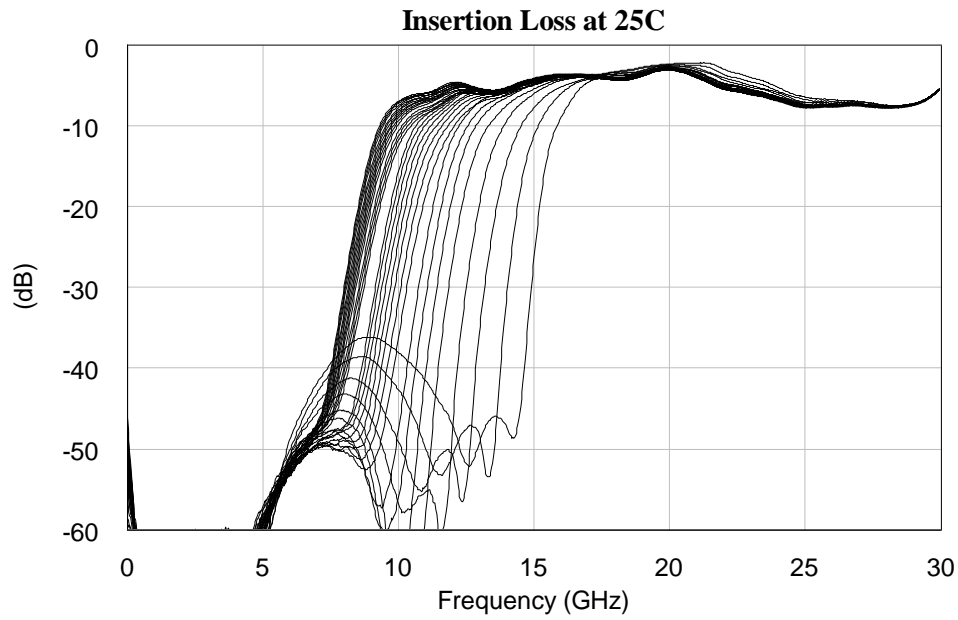

Typical Application

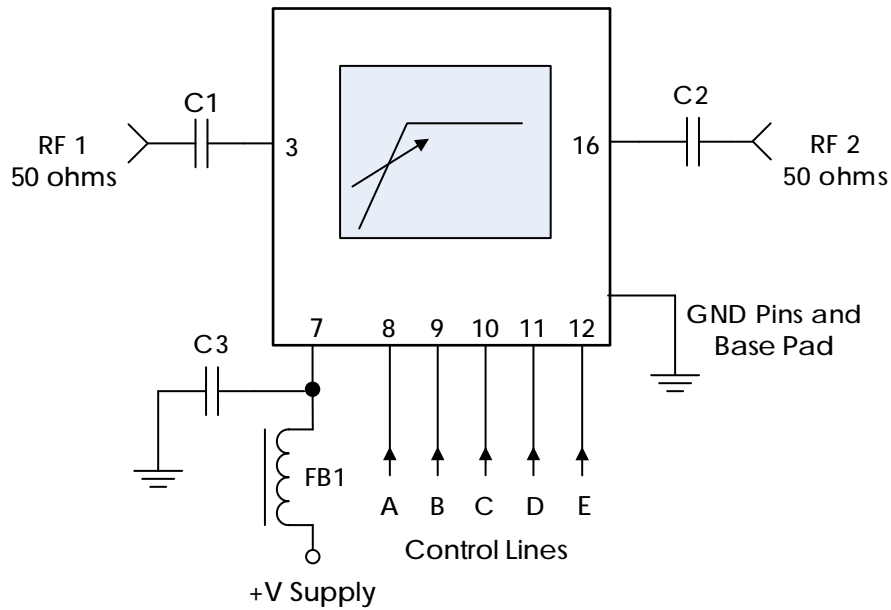

Recommended Component List (or equivalent):

Part	Value	Part Number	Manufacturer
C1, C2	0.1 μ F	0201BB104KW160	Passives Plus
C3	0.1 μ F	C1005X7R1H104K050BB	TDK
FB1	-	MMZ1005A222E	TDK

Notes:

1. RF blocking capacitors should be high performance, low-loss, broadband capacitors for optimum performance.
2. RC filtering on the control lines is recommended to prevent digital noise from coupling to the RF path.
 - a. Select control line RC filter values based on desired logic source decoupling and switching speed.

AM3108 – Filter Bank



Digitally Tunable 12.0 to 18.0 GHz Highpass

Package Details

Package Drawing

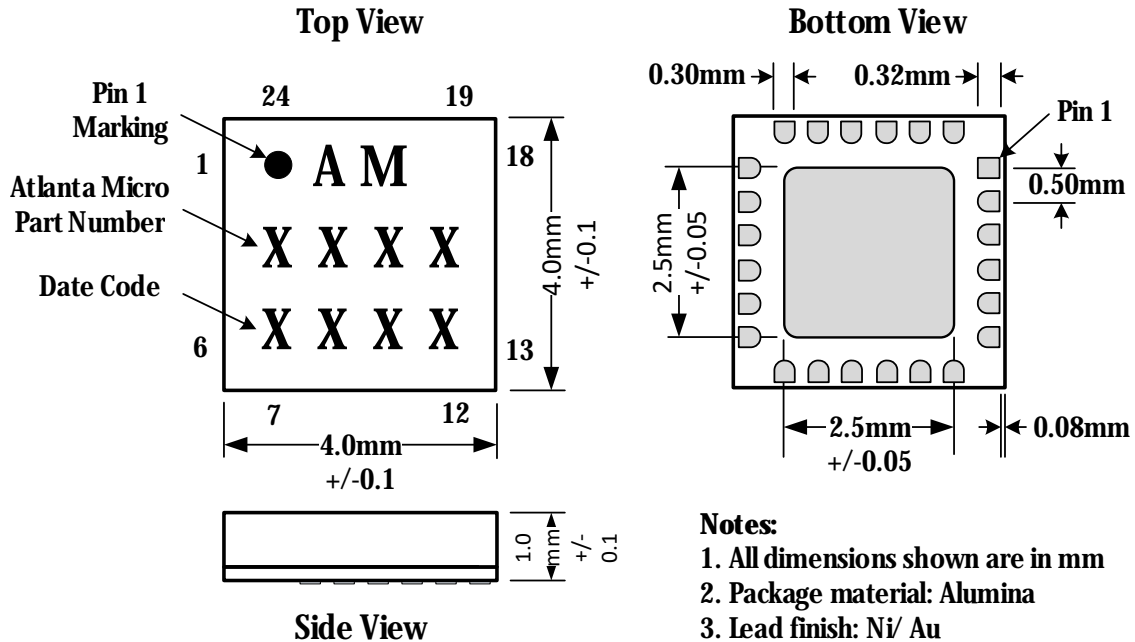

Recommended Footprint

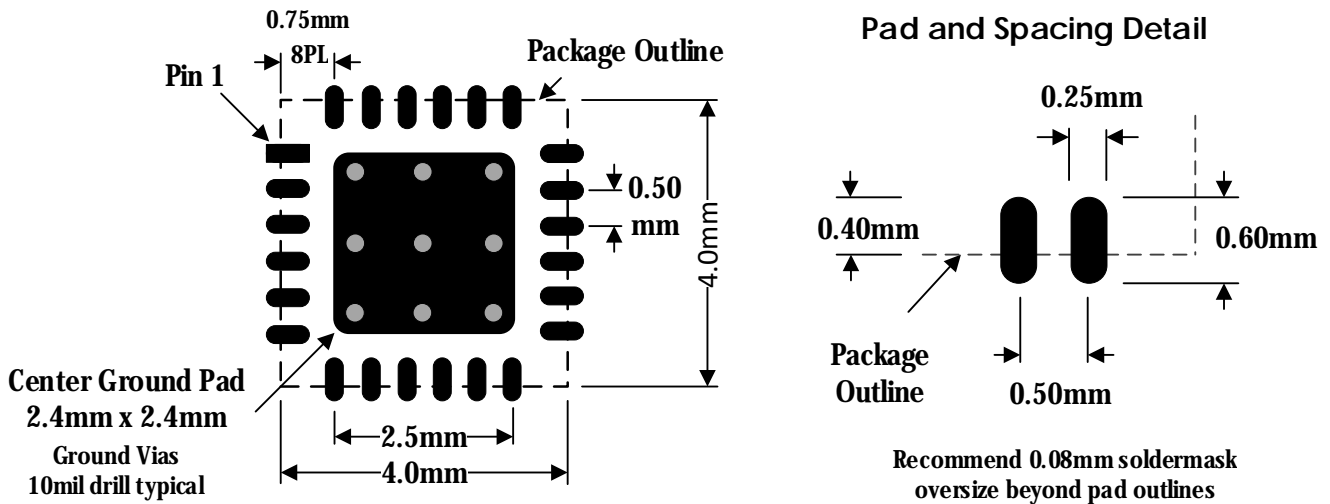

AM3108 – Filter Bank

Digitally Tunable 12.0 to 18.0 GHz Highpass

Evaluation PC Board

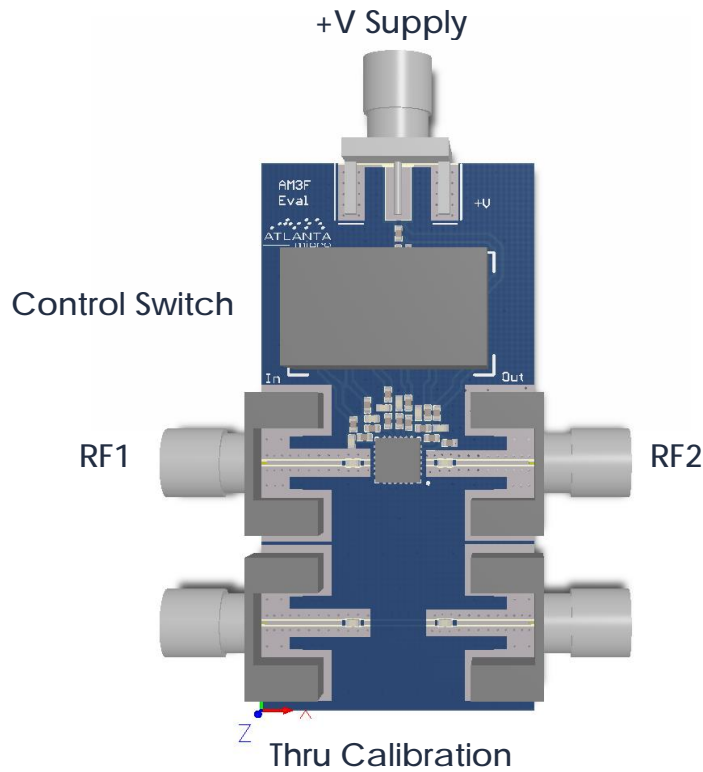

Related Parts

Part Number	Description			
AM3030	3.5 GHz	to	6.5 GHz	Digitally Tunable Lowpass
AM3039	9 GHz	to	18 GHz	Digitally Tunable Lowpass
AM3107	6 GHz	to	12 GHz	Digitally Tunable Lowpass
AM3110	18 GHz	to	26.5 GHz	Digitally Tunable Lowpass
AM3032	2.5 GHz	to	4.5 GHz	Digitally Tunable Highpass
AM3041	6 GHz	to	10 GHz	Digitally Tunable Highpass
AM3109	18 GHz	to	26.5 GHz	Digitally Tunable Highpass

Component Compliance Information

RoHS: Atlanta Micro, Inc. hereby certifies that all products comply with the EC Directive 2011/65/EC on the Restriction of Hazardous Substances, commonly known as RoHS II. All products supplied by Atlanta Micro shall be compliant with the European Directive 2011/65/EC based on the following substance list.

Substance List	Allowable Maximum Concentration
Lead (Pb)	<1000 PPM (0.1% by weight)
Mercury (Hg)	<1000 PPM (0.1% by weight)
Cadmium (Cd)	<75 PPM (0.0075% by weight)
Hexavalent Chromium (CrVI)	<1000 PPM (0.1% by weight)
Polybrominated Biphenyls (PBB)	<1000 PPM (0.1% by weight)
Polybrominated Diphenyl ethers (PBDE)	<1000 PPM (0.1% by weight)
Decabromodiphenyl Deca BDE	<1000 PPM (0.1% by weight)

REACH: Atlanta Micro, Inc. neither uses nor intentionally adds any of the substances considered to be a Substance of Very High Concern (SVHC) as defined by the EU Regulation (EC) No. 1907-2006 on Registration, Evaluation, Authorization, and Restriction of Chemicals (REACH).

Conflict Materials: Atlanta Micro does not knowingly use materials that are sourced from the Democratic Republic of Congo (DRC) or any other known conflict regions. Atlanta Micro's supply chain is comprised of sources that are both environmentally and socially responsible. We periodically review this requirement with our vendors to ensure continued compliance.

Atlanta Micro takes its responsibility as a global partner seriously and will use due diligence within our supply chain to ensure all standards are met to the best of our knowledge.