

# Flexor 7070

## PCI Express Virtex-7 processor and FMC carrier

### FMC carrier offers optical interface

- Incorporates the VITA 66.4 standard for half-size MT optical interconnect
- Provides 12 optical duplex lanes to the backplane
- Robust solution for high data rate demands
- VITA-57.1 FMC site offers access to a wide range of possible I/O



**The Flexor® Model 7070 is a high-performance PCIe board based on the Xilinx Virtex-7 FPGA.** As a stand-alone processor board, it provides an ideal development and deployment platform for demanding signal processing applications.

The 7070 includes a VITA-57.1 FMC site providing access to a wide range of I/O options. When combined with any of Mercury's analog interface FMCs, it becomes a complete multichannel data conversion and processing subsystem suitable for connection to IF, HF or RF ports of a communications or radar system.

The 7070 architecture includes an optional built-in gigabit serial optical interface. Up to 12 high-speed duplex optical lanes are available on an MTP connector. With the installation of a serial protocol in the FPGA, this interface enables a high-bandwidth connection between 7070s mounted in the same chassis or even over extended distances between them.

### FEATURES

- VITA-57.1 FMC site offers access to a wide range of possible I/O
- Supports Xilinx® Virtex®-7 VXT FPGA
- GateXpress® supports dynamic FPGA reconfiguration across PCIe
- 4 GB of DDR3 SDRAM
- PCI Express (Gen. 1, 2 and 3) interface up to x8
- Optional user-configurable 12X optical gigabit serial interface
- Optional LVDS connections to the Virtex-7 FPGA for custom I/O
- Ruggedized and conduction-cooled versions available
- Free lifetime applications support

7070 BLOCK DIAGRAM

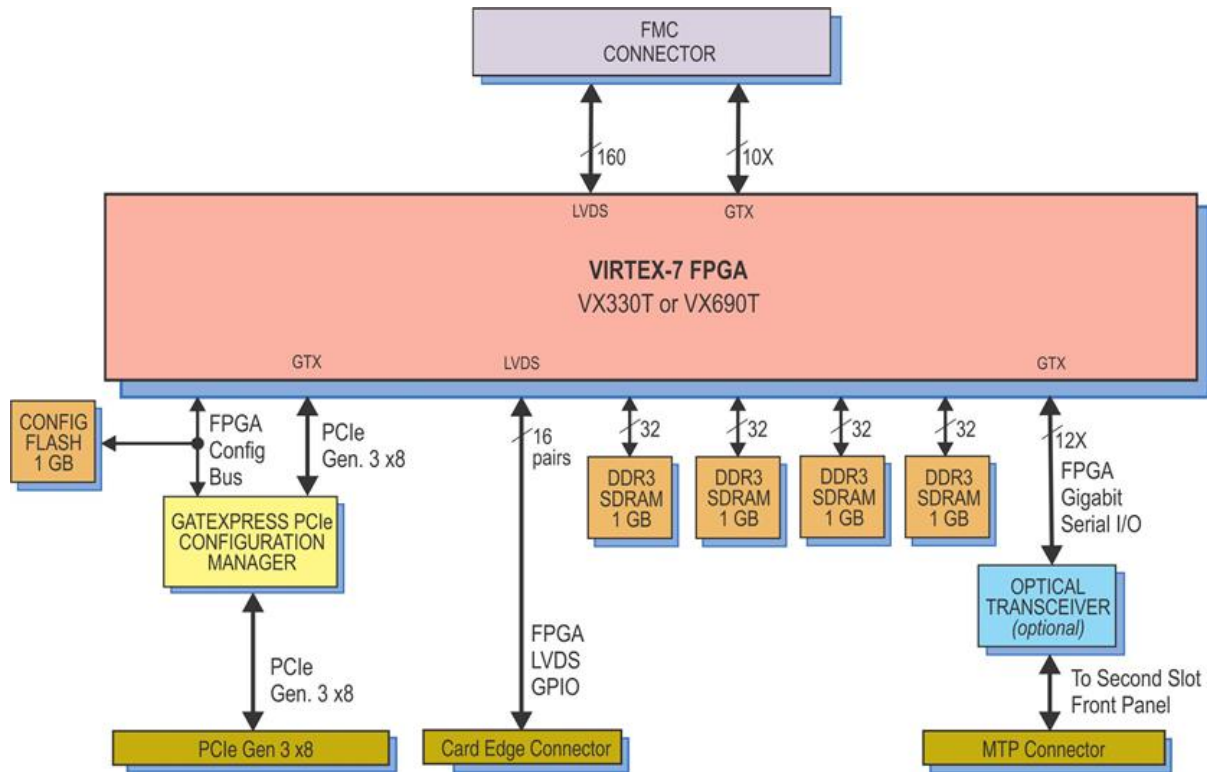

BOARD ARCHITECTURE

Based on the proven design of the Mercury Onyx family of Virtex-7 products, the 7070 retains all of the key features of that family. As a central foundation of the board architecture, the FPGA has access to all data and control paths of both the main board and the FMC module, enabling factory-installed functions including data multiplexing, channel selection, data packing, gating, triggering and memory control.

The architecture organizes the FPGA as a container for data processing applications where each function exists as an intellectual property (IP) module. When integrated with a Mercury FMC, the 7070 is delivered with factory-installed applications ideally matched to the board’s analog or digital interfaces. These can include A/D acquisition and D/A waveform playback engines for simplifying data capture and playback.

Data tagging and metadata packet generation, in conjunction with powerful linked-list DMA engines, provide a streamlined interface for moving data on and off the board and identifying

data packets with channel, timing and sample -count information.

IP modules for DDR3 SDRAM memories, controllers for all data clocking and synchronization functions, a test signal generator, and a PCIe interface complete the factory-installed functions and enable the 7070 and installed FMC to operate as a complete turnkey solution without the need to develop any FPGA IP.

EXTENDABLE IP DESIGN

For applications that require specialized functions, users can install their own custom IP for data processing. Using Xilinx® Vivado® tools, developers can integrate their own IP with the Mercury factory-installed functions or use the development kit to completely replace the Mercury IP with their own.

## XILINX VIRTEX-7 FPGA

The 7070 can be optionally populated with one of two Virtex-7 FPGAs to match the specific requirements of the processing task. Supported FPGAs are VX330T or VX690T. The VX690T features 3600 DSP48E1 slices and is ideal for modulation/demodulation, encoding/decoding, encryption/decryption, and channelization of the signals between transmission and reception. For applications not requiring large DSP resources or logic, the lower-cost VX330T can be installed.

Sixteen pairs of LVDS connections are optionally provided between the FPGA and a card edge connector for custom I/O. For applications requiring custom gigabit links, up to 12 high-speed, full-duplex FPGA GTX lanes driven via an optical transceiver support serial protocols. A 12-lane MTP optical connector is presented on a PCIe slot panel that can be installed in an empty, adjacent PCIe slot.

When configured with a VX330T FPGA, four duplex lanes are available.

## GATEXPRESS FOR FPGA CONFIGURATION

The 7070 architecture includes GateXpress, a sophisticated FPGA-PCIe configuration manager for loading and reloading the FPGA. At power up, GateXpress immediately presents a PCIe target for the host computer to discover, effectively giving the FPGA time to load from FLASH. This is especially important for larger FPGAs where the loading times can exceed the PCIe discovery window, typically 100 msec on most SBCs.

The board's configuration FLASH can hold four FPGA images. Images can be factory-installed IP or custom IP created by the user and programmed into the FLASH via JTAG using Xilinx iMPACT or through the board's PCIe interface. At power up the user can choose which image will load based on a hardware switch setting.

Once booted, GateXpress allows the user three options for dynamically reconfiguring the FPGA with a new IP image. The first is the option to load an alternate image from FLASH through software control. The user selects the desired image and issues a reload command.

The second option is for applications where the FPGA image must be loaded directly through the PCIe interface. This is important in security situations where there can be no latent user image left in nonvolatile memory when power is removed. In applications where the FPGA IP may need to change many times during the course of a mission, images can be stored on the host computer and loaded through PCIe as needed.

The third option, typically used during development, allows the user to directly load the FPGA through JTAG using Xilinx iMPACT.

In all three FPGA loading scenarios, GateXpress handles the hardware negotiation simplifying and streamlining the loading task. In addition, GateXpress preserves the PCIe configuration space allowing dynamic FPGA reconfiguration without needing to reset the host computer to rediscover the board. After the reload, the host simply continues to see the board with the expected device ID.

The board's configuration FLASH can hold four FPGA images. Images can be factory-installed IP or custom IP created by the user, and programmed into the FLASH via JTAG using Xilinx iMPACT or through the board's PCIe interface. At power up the user can choose which image will load based on a hardware switch setting. Once booted, GateXpress allows the user three options for dynamically reconfiguring the FPGA with a new IP image:

- The first is the option to load an alternate image from FLASH through software control. The user selects the desired image and issues a reload command.
- The second option is for applications where the FPGA image must be loaded directly through the PCIe interface. This is important in security situations where there can be no latent user image left in nonvolatile memory when power is removed. In applications where the FPGA IP may need to change many times during the course of a mission, images can be stored on the host computer and loaded through PCIe as needed.
- The third option, typically used during development, allows the user to directly load the FPGA through JTAG using Xilinx iMPACT.

In all three FPGA loading scenarios, GateXpress handles the hardware negotiation simplifying and streamlining the loading task. In addition, GateXpress preserves the PCIe configuration space allowing dynamic FPGA reconfiguration without a host computer reset to rediscover the board. After the reload, the host simply continues to see the board with the expected device ID.

**FRONT PANEL CONNECTIONS**

The 7070 carrier PCIe slot panel houses the front panel of the FMC module installed on the carrier. It includes three LED indicators and an optional PPS IN or Optical I/O connector.

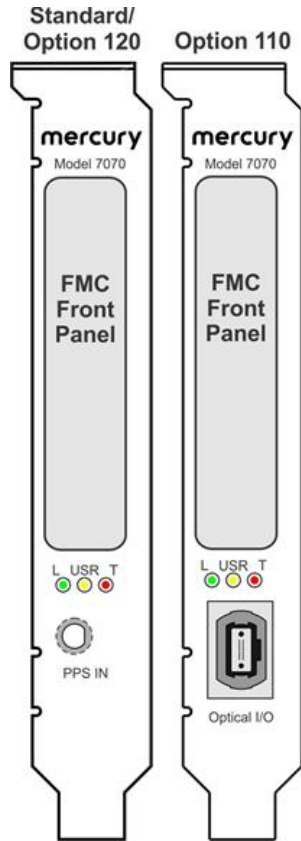

- **LINK LED:** The green LNK (L) LED illuminates when a valid PCIe link has been established over the PCIe interface.
- **User LED:** The yellow USR LED is available for user applications.
- **Over Temperature LED:** The red (T) LED illuminates when an over-temperature or over-voltage condition is indicated by any of the temperature/voltage sensors on the model.
- **PPS Input Connector** (Option 120 only): With Option 120, a PPS IN connector on the standard front panel provides input of an external PPS or Sync signal. Without Option 120, the PPS IN connector is not active and is covered with a plug, as indicated by the dotted circle in the illustration.

**SPECIFICATIONS**

**I/O Module Interface**

VITA-57.1, High Pin Count FMC site

**Field Programmable Gate Array**

- Standard: Xilinx Virtex-7 XC7VX330T-2
- Option -076: Xilinx Virtex-7 XC7VX690T-2

**Custom FPGA I/O**

Parallel (Option -104): 16 pairs of LVDS connections between the FPGA and a card-edge connector for custom I/O

Optical (Option -110): 12x gigabit serial option I/O with XC7VX690T FPGA, 4x with XC7VX330T optical gigabit serial interface, MTP connector installed in an empty adjacent slot

**Memory**

Type: DDR3 SDRAM

Size: Four banks, 1 GB each

Speed: 800 MHz (1600 MHz DDR)

**PCI-Express Interface**

PCI Express Bus: Gen. 1, 2 or 3: x4 or x8

**Environmental**

Standard: L0 (air-cooled)

- Operating Temp: 0° to 50° C
- Storage Temp: -20° to 90° C
- Relative Humidity: 0 to 95%, non-condensing

Option -702: L2 (air-cooled)

- Operating Temp: -20° to 65° C
- Storage Temp: -40° to 100° C
- Relative Humidity: 0 to 95%, non-condensing

**Physical**

Dimensions: Half-length PCIe card

- Depth: 201.6 mm (7.948 in.)
- Height: 111.2 mm (4.376 in.)

FLEXORSET MODELS

This chart shows all available FlexorSets. Click on model numbers for more information.

Form Factor	Software/FPGA Tools	Carrier Model	FMC Model	FlexorSet Model	Description
3U VPX	Virtex-7 ReadyFlow BSP GateFlow FDK Vivado	5973	3312	5973-312	4-Channel 250 MHz A/D & 2-Channel 800 MHz D/A
				5973-313	4-Channel 250 MHz A/D & 2-Channel 800 MHz D/A with 4 multiband DDCs & interpolation filters
			3316	5973-316	8-Channel 250 MHz 16-bit A/D
				5973-317	8-Channel 250 MHz 16-bit A/D with 8 multiband DDCs
			3320	5973-320	2-Channel 3 GHz A/D & 2-Channel 2.8 GHz D/A
			3324	5973-324	4-Channel 500 MHz A/D & 4-Channel 2 GHz D/A
	KintexUltraScale Navigator BSP Navigator FDK Vivado	5983*	3312	5983-313*	4-Channel 250 MHz A/D & 2-Channel 800 MHz D/A with 4 multiband DDCs & interpolation filters
				5983-317*	8-Channel 250 MHz 16-bit A/D with 8 multiband DDCs
			3320	5983-320*	2-Channel 3 GHz A/D & 2-Channel 2.8 GHz D/A
			3324	5983-324*	4-Channel 500 MHz A/D & 4-Channel 2 GHz D/A
PCIe	Virtex-7 ReadyFlow BSP GateFlow FDK Vivado	7070	3312	7070-312	4-Channel 250 MHz A/D & 2-Channel 800 MHz D/A
				7070-313	4-Channel 250 MHz A/D & 2-Channel 800 MHz D/A with 4 multiband DDCs & interpolation filters
			3316	7070-316	8-Channel 250 MHz 16-bit A/D
				7070-317	8-Channel 250 MHz 16-bit A/D with 8 multiband DDCs
			3320	7070-320	2-Channel 3 GHz A/D & 2-Channel 2.8 GHz D/A
			3324	7070-324	4-Channel 500 MHz A/D & 4-Channel 2 GHz D/A

\*There is a 5983A version of this product. For differences, see below.

Model 5983	Model 5983A
<p><b>Flash Memory</b> - 1 Gbit of FLASH Memory</p> <p><b>Optical I/O (Option 110) - VITA 66.4</b> - Up to 12 duplex optical lanes are available on a VITA 66.4 connector.</p> <p>With the installation of a serial protocol, the VITA 66.4 interface enables a high-bandwidth connection between 5983s mounted in the same chassis or over extended distances.</p>	<p><b>Flash Memory</b> -2 Gbit of BPI FLASH Memory</p> <p><b>Optical I/O (Option 110) - VITA 67.3D</b> - Provides 12 duplex lanes @ 10 Gb/sec through the lower half of VPX P2 (VPX P2B).</p> <p>With the installation of a serial protocol, the VITA 67.3D interface enables gigabit communications between boards and chassis, independent of the PCIe interface.</p>
	<p><b>Custom Analog I/O (Option 113) - VITA 67.3</b> - VITA 67.3 provides 10 coax connections through the lower half of VPX P2.</p>

**DEVELOPMENT SYSTEMS**

Mercury offers development systems for Flexor products. They come with all pre-tested software and hardware ready for immediate operation. These systems are intended to save engineers and system integrators the time and expense associated with building and testing a development system that ensures optimum performance of Flexor boards. Please contact Mercury to configure a system that matches your requirements.

**ORDERING INFORMATION**

Model	Description
7070	PCI Express Virtex-7 processor and FMC carrier - x8 PCIe

**Options:**

-076	XC7VX690T-2 FPGA
-104	LVDS FPGA I/O to card-edge connector
-110	12x gigabit serial optical I/O with XC7VX690T FPGA, 4X with XC7VX330T
-702	Air-cooled, Level 2

Contact Mercury for compatible option combinations and complete specifications of rugged and conduction-cooled versions. Options may change, so be sure to contact Mercury for the latest information.

**LIFETIME SUPPORT FOR FLEXOR PRODUCTS**

Mercury offers worldwide customers shorter development time, reliable, rugged solutions for a variety of environments, reduced costs, and mature software development tools. We offer free lifetime support from our engineering staff, which customers can depend on through phone and email, as well as software updates. Take advantage of our 40 years of experience in delivering high-performance radar, communications, SIGINT, EW, and data acquisition MIL-Aero solutions worldwide.



**Corporate Headquarters**

50 Minuteman Road  
 Andover, MA 01810 USA  
**+1 978.967.1401** tel  
**+1 866.627.6951** tel  
**+1 978.256.3599** fax

**International Headquarters**

**Mercury International**  
 Avenue Eugène-Lance, 38  
 PO Box 584  
 CH-1212 Grand-Lancy 1  
 Geneva, Switzerland  
**+41 22 884 5100** tel

**Learn more**

**Visit:** [mrcy.com/go/MP7070](http://mrcy.com/go/MP7070)

**For technical details, contact:**  
[mrcy.com/CF7070](http://mrcy.com/CF7070)



The Mercury Systems logo and the following are trademarks or registered trademarks of Mercury Systems, Inc.: Mercury Systems, Innovation That Matters, Cobalt, Flexor, FlexorSet, and Onyx. Other marks used herein may be trademarks or registered trademarks of their respective holders. Mercury believes this information is accurate as of its publication date and is not responsible for any inadvertent errors. The information contained herein is subject to change without notice.

