

# AM3137 – Filter Bank

## Analog Tunable 0.8 to 1.8 GHz Notch

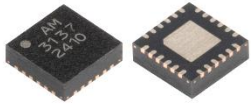

**AM3137 is an analog voltage-tunable notch filter bank covering the 0.8 GHz to 1.8 GHz frequency range.** The AM3137 offers two MMIC chips covering 0.8 GHz to 1.3 GHz and 1.1 GHz to 1.8 GHz for fine granularity within the AM3137's operating range. Two separate tune voltages provide precise control of center frequency and notch bandwidth. The AM3137 provides an excellent filtering solution for a receiver or transceiver requiring flexible center frequency removal, high dynamic range, low insertion loss, and small size, low weight, and low power consumption (low SWAP).

### FEATURES

- Analog Tuning
- 2 dB Typical Insertion Loss
- 30+ dB Typical Rejection
- BW 20% of Tuned Frequency, TYP
- 0.0V to +6.0V Tuning Voltage Range
- 4mm QFN Package
- -40C to +85C Operation

### FUNCTIONAL DIAGRAM

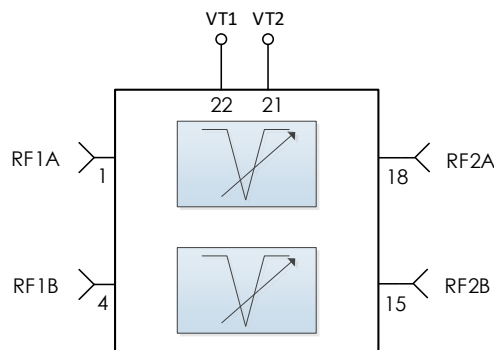

### CHARACTERISTIC PERFORMANCE

(Note: Only some states shown for simplicity.)

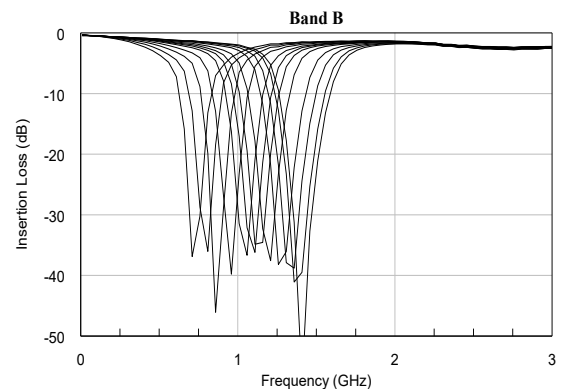
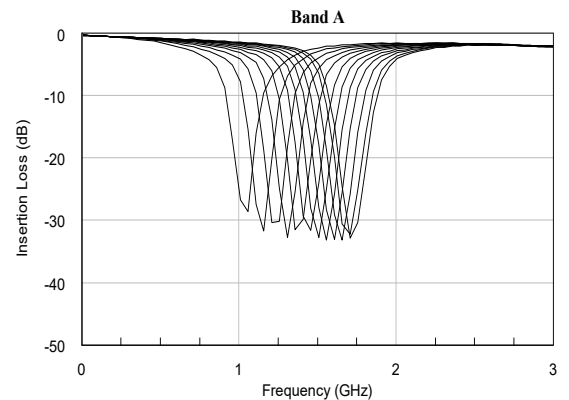

CONTENTS

FEATURES ..... 1

FUNCTIONAL DIAGRAM ..... 1

CHARACTERISTIC PERFORMANCE ..... 1

REVISION HISTORY ..... 2

PIN LAYOUT AND DEFINITIONS ..... 3

SPECIFICATIONS ..... 4

TYPICAL PERFORMANCE ..... 6

TYPICAL APPLICATION ..... 7

EVALUTATION PC BOARD ..... 8

RELATED PARTS ..... 8

COMPONENT COMPLIANCE INFORMATION ..... 9

REVISION HISTORY

Date	Revision	Notes
January 24, 2019	1	Initial Release.
July 10, 2024	2	Changed to Mercury branding. No content changes.
January 29, 2026	2.1	Corrected package photo, and spec limits

PIN LAYOUT AND DEFINITIONS

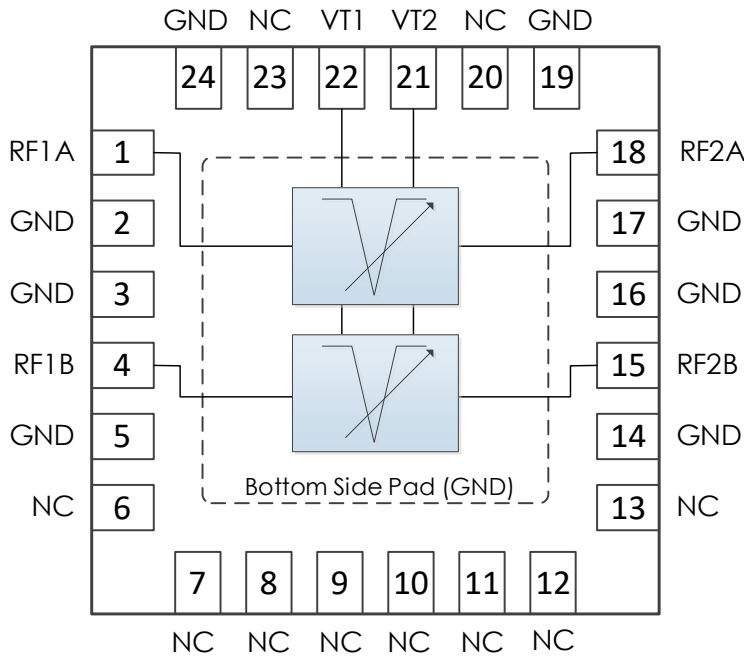

Pin	Name	Function
1	RF1A	RF1A 1.1GHz to 1.8 GHz - 50 Ohms - DC Coupled, External Blocking Capacitor Required
2, 3	GND	Ground - Common
4	RF1B	RF1B 0.8 GHz to 1.3 GHz - 50 Ohms - DC Coupled, External Blocking Capacitor Required
5	GND	Ground - Common
6 -13	NC	No connect *
14	GND	Ground - Common
15	RF2B	RF2B 0.8 GHz to 1.3 GHz - 50 Ohms - DC Coupled, External Blocking Capacitor Required
16, 17	GND	Ground - Common
18	RF2A	RF2A 1.1 GHz to 1.8 GHz - 50 Ohms - DC Coupled, External Blocking Capacitor Required
19	GND	Ground - Common
20	NC	No connect *
21	VT2	Notch Tune Voltage 2
22	VT1	Notch Tune Voltage 1
23	NC	No connect *
24	GND	Ground - Common
Bottom Pad	GND	Ground - Common
*		NC pins can be left open or grounded

SPECIFICATIONS

Absolute Maximum Ratings

	Minimum	Maximum
DC Control Voltage	0.0 V	+10.0 V
RF Input Power		+27 dBm
Operating Junction Temperature	-40 C	+150 C
Storage Temperature Range	-50 C	+150 C

Recommended Operating Conditions

	Minimum	Typical	Maximum
DC Control Voltage	0.0 V		+6.0 V
Operating Case Temperature	-40 C		+85 C
Operating Junction Temperature	-40 C		+125 C

**Note:** Any device operation beyond the Absolute Maximum Ratings may result in permanent damage to the device. The values listed in this table are extremes and do not imply functional operation of the device at these or any other conditions beyond what is listed under Recommended Operating Conditions. Any part subjected to conditions outside of what is recommended for an extended amount of time may suffer from reliability concerns.

Handling Information

	Minimum	Maximum
Storage Temperature Range (Recommended)	-50 C	+125 C
Moisture Sensitivity Level	MSL 1	



Mercury products are electrostatic sensitive. Follow safe handling practices to avoid damage.

**DC Electrical Characteristics**

(T = 25 °C unless otherwise specified)

Param	Testing Conditions	Min	Typical	Max
DC Control Voltage		0.0 V		+6.0 V
DC Control Current			< 1mA	

**RF Performance**

(T = 25 °C unless otherwise specified)

Param	Testing Conditions	Min	Typical	Max
Frequency Range		0.8 GHz		1.8 GHz
Insertion Loss			2.0 dB	
Notch Depth			30 dB	
Return Loss			10 dB	

TYPICAL PERFORMANCE

(Note: Only some states shown for simplicity)

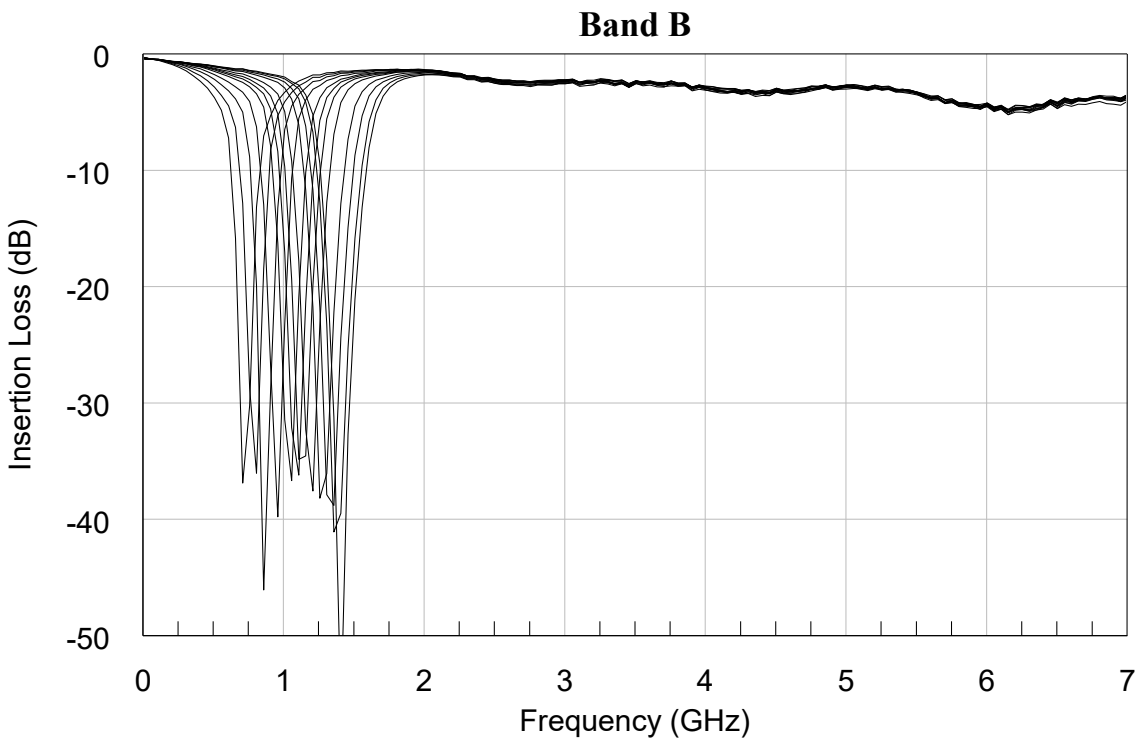
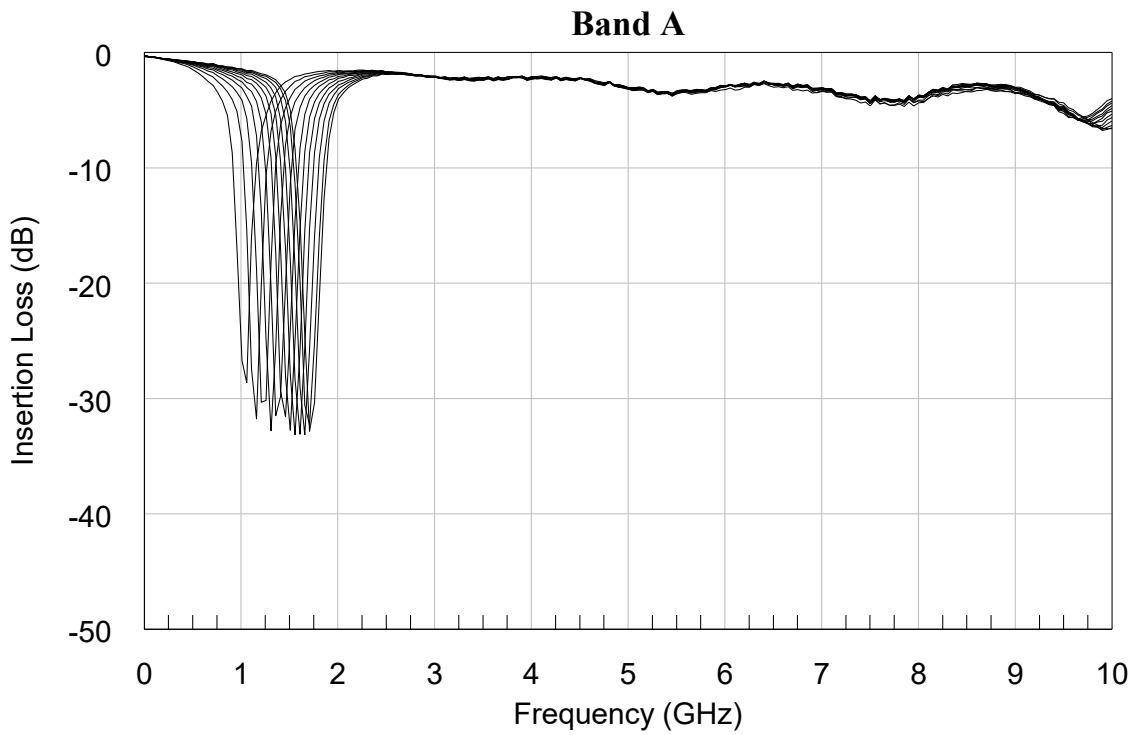

TYPICAL APPLICATION

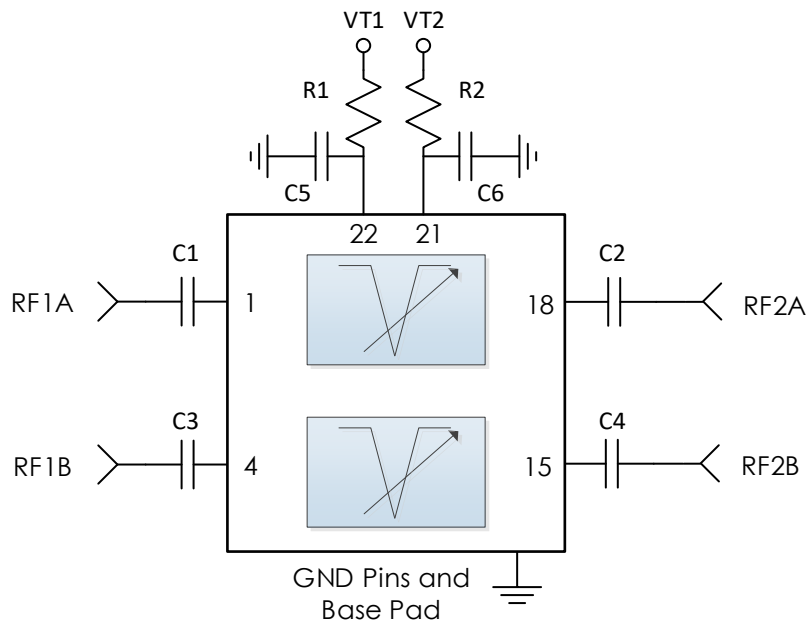

Recommended Component List (or Equivalent)

Part	Value	Part Number	Manufacturer
C1 - C4	0.1 $\mu$ F	0201BB104KW160	Passives Plus
C5-C6	0.1 $\mu$ F	C1005X7R1H104K050BB	TDK
R1, R2	100 $\Omega$	CRCW0402100RFKED	Vishay

Notes:

1. RF filtering on the control lines is recommended to prevent digital noise from coupling to the RF path.
  - a. Select tune voltage line RC filter values based on desired logic source decoupling and switching speed.

EVALUTATION PC BOARD

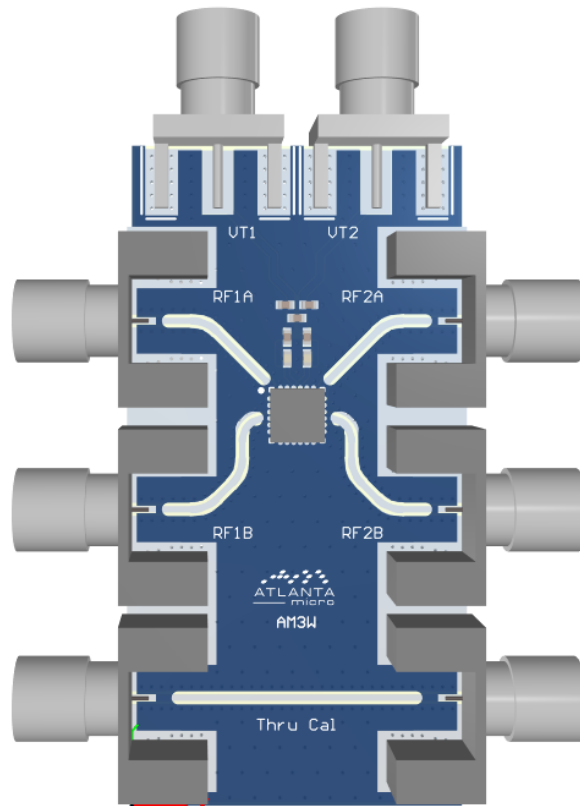

RELATED PARTS

Part Number		Description
AM3129	.7 GHz to 6 GHz	Switched Analog Tunable Notch Bank
AM3138	1.3 GHz to 3.25 GHz	Analog Tunable Notch Filter Bank
AM3139	2.5 GHz to 6 GHz	Analog Tunable Notch Filter Bank
AM3089	2 GHz to 18 GHz	Switched Analog Tunable BPF Bank
AM3134	2 GHz to 4.5 GHz	Analog Tunable Bandpass Filter Bank
AM3135	3.5 GHz to 9 GHz	Analog Tunable Bandpass Filter Bank
AM3136	8. GHz to 19 GHz	Analog Tunable Bandpass Filter Bank

COMPONENT COMPLIANCE INFORMATION

**RoHS:** Mercury Systems, Inc. hereby certifies that all products comply with the EC Directive 2011/65/EC on the Restriction of Hazardous Substances, commonly known as EU-RoHS 6 and 10. All products supplied by Mercury shall be compliant with the European Directive 2011/65/EC based on the following substance list.

Substance List	Allowable Maximum Concentration
Lead (Pb)	<1000 PPM (0.1% by weight)
Mercury (Hg)	<1000 PPM (0.1% by weight)
Cadmium (Cd)	<75 PPM (0.0075% by weight)
Hexavalent Chromium (CrVI)	<1000 PPM (0.1% by weight)
Polybrominated Biphenyls (PBB)	<1000 PPM (0.1% by weight)
Polybrominated Diphenyl ethers (PBDE)	<1000 PPM (0.1% by weight)
Decabromodiphenyl Deca BDE	<1000 PPM (0.1% by weight)

**REACH:** Mercury Systems, Inc. neither uses nor intentionally adds any of the substances considered to be a Substance of Very High Concern (SVHC) as defined by the EU Regulation (EC) No. 1907-2006 on Registration, Evaluation, Authorization, and Restriction of Chemicals (REACH).

**Conflict Materials:** Mercury does not knowingly use materials that are sourced from the Democratic Republic of Congo (DRC) or any other known conflict regions. Mercury’s supply chain is comprised of sources that are both environmentally and socially responsible. We periodically review this requirement with our vendors to ensure continued compliance.

**Mercury takes its responsibility as a global partner seriously and will use due diligence within our supply chain to ensure all standards are met to the best of our knowledge.**



**Corporate Headquarters**

50 Minuteman Road  
 Andover, MA 01810 USA  
 +1 978.967.1401 tel  
 +1 866.627.6951 tel  
 +1 978.256.3599 fax

**International Headquarters**

**Mercury International**

Avenue Eugène-Lance, 38  
 PO Box 584  
 CH-1212 Grand-Lancy 1  
 Geneva, Switzerland  
 +41 22 884 5100 tel

**Learn more**

**Visit:** [mrcy.com](http://mrcy.com)

For pricing details, contact: [MMICsales@mrcy.com](mailto:MMICsales@mrcy.com)

For technical details, contact: [MMICsupport@mrcy.com](mailto:MMICsupport@mrcy.com)



The Mercury Systems logo is a registered trademark of Mercury Systems, Inc. Other marks used herein may be trademarks or registered trademarks of their respective holders. Mercury products identified in this document conform with the specifications and standards described herein. Conformance to any such standards is based solely on Mercury’s internal processes and methods. The information contained in this document is subject to change at any time without notice.

