

# AM3153 – Filter Bank

## Digitally Tunable 6 to 26.5 GHz Bandpass

### Description

AM3153 is a digitally tunable bandpass filter bank covering 6 GHz to 26.5 GHz. The device provides three separate tunable filter bands with 16 selectable bandpass states each. The filter bank has integrated switches with a 22 GHz bypass path. AM3153 is packaged in a 5mm QFN package and operates over the -40C to +85C temperature range.



### Features

- Digitally Tunable Bandpass Filter Bank
- Integrated SP4T Switches
- Internal Control Line Filtering
- +3.3V to +5.0V Supply
- 10 dB typical Insertion Loss
- 22 GHz Filter Bypass Path
- +39 dBm Input IP3
- +26 dBm Input P1dB
- -40C to +85C Operation
- 5mm QFN package

### Functional Diagram

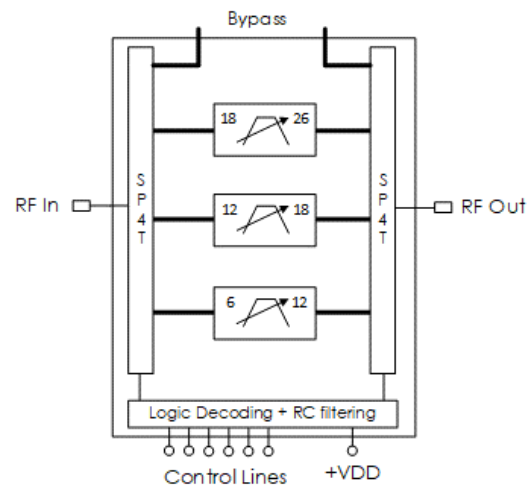

### Characteristic Performance

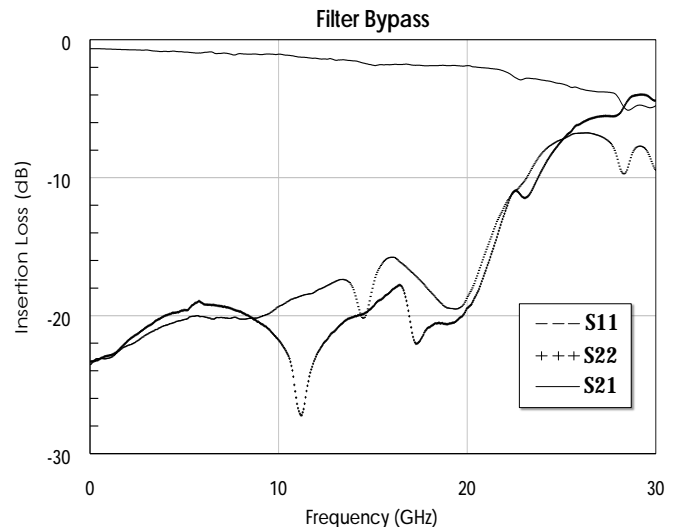
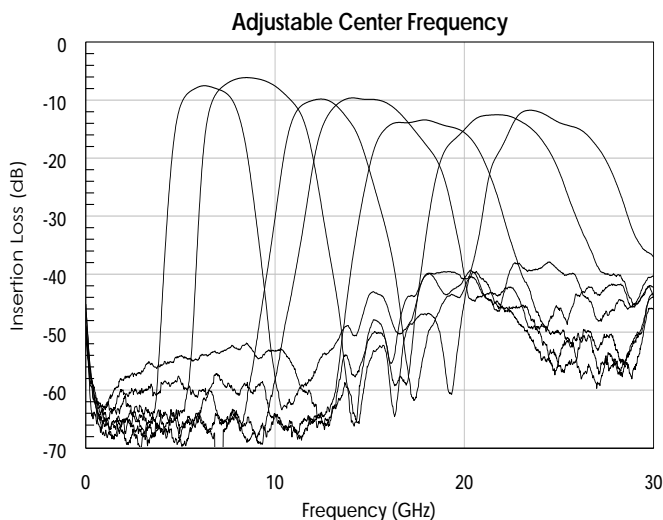

### Table of Contents

Description .....	1	DC Electrical Characteristics.....	5
Features.....	1	RF Performance .....	5
Functional Diagram.....	1	Timing Characteristics .....	5
Characteristic Performance .....	1	State Table .....	6
Revision History .....	2	Typical Performance .....	8
Pin Layout and Definitions.....	3	Typical Application.....	10
Specifications .....	4	Evaluation PC Board .....	11
Absolute Maximum Ratings.....	4	Related Parts.....	11
Handling Information.....	4	Component Compliance Information.....	12
Recommended Operating Conditions....	4		

### Revision History

Date	Revision Number	Notes
June 5, 2020	1	Initial Release
June 15, 2021	2	Update figures

# AM3153 – Filter Bank

Digitally Tunable 6 to 26.5 GHz Bandpass

## Pin Layout and Definitions

Note: All Non-Named Pins are GND

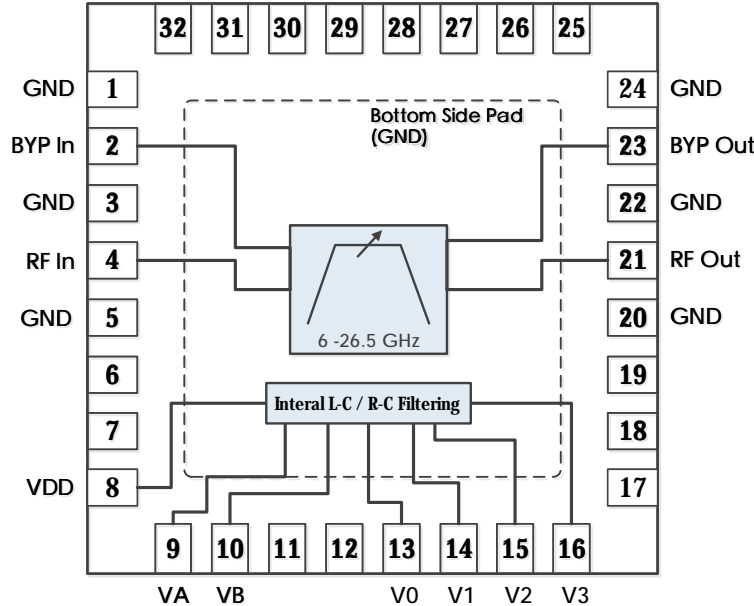

Pin Number	Pin Name	Pin Function
1	GND	Ground – Common
2	BYP In	Filter Bypass Input Side – 50 Ohms – DC Coupled, External DC Blocking Cap Required
3	GND	Ground – Common
4	RF In	RF Input – 50 Ohms – DC Coupled, External DC Blocking Cap Required
5-7	GND	Ground – Common
8	VDD	DC Power Input
9	VA	Switch Control A
10	VB	Switch Control B
11-12	GND	Ground – Common
13	V0	Band Pass Filter Control Bit 0 (LSB)
14	V1	Band Pass Filter Control Bit 1
15	V2	Band Pass Filter Control Bit 2
16	V3	Band Pass Filter Control Bit 3
17-20	GND	Ground – Common
21	RF Out	RF Output – 50 Ohms – DC Coupled, External DC Blocking Cap Required
22	GND	Ground – Common
23	BYP Out	Filter Bypass Output Side – 50 Ohms – DC Coupled, External DC Blocking Cap Required
24-32	GND	Ground – Common
Bottom Pad	GND	Ground – Common

To obtain price, delivery, or to place an order contact [MMICSales@mrcty.com](mailto:MMICSales@mrcty.com)  
 Atlanta Micro Inc., 3720 Davinci Ct, Suite 125, Peachtree Corners, GA 30092 • Phone: (470) 253-7640 • [www.atlantamicro.com](http://www.atlantamicro.com)

# AM3153 – Filter Bank



Digitally Tunable 6 to 26.5 GHz Bandpass

## Specifications

### Absolute Maximum Ratings

	Minimum	Maximum
Supply Voltage	-0.3 V	+6.0 V
RF Input Power		+27 dBm
Operating Junction Temperature	-40 C	+150 C
Storage Temperature Range	-50 C	+150 C

**Note:** Any device operation beyond the Absolute Maximum Ratings may result in permanent damage to the device. The values listed in this table are extremes and do not imply functional operation of the device at these or any other conditions beyond what is listed under Recommended Operating Conditions. Any part subjected to conditions outside of what is recommended for an extended amount of time may suffer from reliability concerns.

### Handling Information

	Minimum	Maximum
Storage Temperature Range (Recommended)	-50 C	+125 C
Moisture Sensitivity Level	MSL 3	



Atlanta Micro products are electrostatic sensitive.  
Follow safe handling practices to avoid damage

### Recommended Operating Conditions

	Minimum	Typical	Maximum
Supply Voltage	+3.0 V	+5.0 V	+5.2 V
Operating Case Temperature	-40 C		+85 C
Operating Junction Temperature	-40 C		+125 C

# AM3153 – Filter Bank

## Digitally Tunable 6 to 26.5 GHz Bandpass

### DC Electrical Characteristics

(T = 25 °C unless otherwise specified)

Parameter	Testing Conditions	Minimum	Typical	Maximum
DC Supply Voltage		+3.0 V	+5.0 V	+5.2 V
DC Supply Current	VDD = +5.0 V		6 mA	
Power Dissipated	VDD = +5.0 V		30 mW	
Logic Level Low		-0.1 V		+0.5 V
Logic Level High		+2.0 V		+VDD V

**Note:** Operating the AM3153 at VDD levels below +5.0V can cause corner frequencies to shift down by up to 2%. It is recommended to use +5.0V when possible. Control voltage level does not affect filter corner frequencies.

### RF Performance

(T = 25 °C unless otherwise specified)

Parameter	Testing Conditions	Minimum	Typical	Maximum
Frequency Range		6 GHz		26.5 GHz
Insertion Loss	f = 6 GHz		-7.5 dB	
	f = 9 GHz		-6 dB	
	f = 12 GHz		-8 dB	
	f = 15 GHz		-10 dB	
	f = 18 GHz		-12.5 dB	
	f = 22 GHz		-12.5 dB	
	f = 26 GHz		-15 dB	
Return Loss			-12 dB	
Input IP3	VDD = +5.0 V		+39 dBm	
Input P1dB	VDD = +5.0 V		+26 dBm	

**Note:** IP3 was measured with 10MHz tone spacing

### Timing Characteristics

Parameter	Minimum	Typical	Maximum
Switching Speed		40 ns	
Band Tuning Speed		400 ns	

**Note:** Timing characteristics measured from 50% control to 90% RF.

# AM3153 – Filter Bank



## Digitally Tunable 6 to 26.5 GHz Bandpass

### State Table

VA	VB	V3	V2	V1	V0	Typical Cutoff Frequency (GHz)	
						HP cutoff	LP cutoff
						Bypass enabled	Bypass enabled
L	L	X	X	X	X		
H	H	L	L	L	L	5.1	7.8
H	H	L	L	L	H	5.2	8
H	H	L	L	H	L	5.3	8.1
H	H	L	L	H	H	5.3	8.3
H	H	L	H	L	L	5.4	8.6
H	H	L	H	L	H	5.5	8.8
H	H	L	H	H	L	5.7	9
H	H	L	H	H	H	5.9	9.1
H	H	H	L	L	L	5.8	9.2
H	H	H	L	L	H	6	9.5
H	H	H	L	H	L	6.3	9.8
H	H	H	L	H	H	6.5	10.1
H	H	H	H	L	L	6.8	10.6
H	H	H	H	L	H	7.3	11
H	H	H	H	H	L	8.1	11.6
H	H	H	H	H	H	9.1	12.3
L	H	L	L	L	L	11	13.8
L	H	L	L	L	H	11.1	13.9
L	H	L	L	H	L	11.2	14.1
L	H	L	L	H	H	11.4	14.4
L	H	L	H	L	L	11.4	14.5
L	H	L	H	L	H	11.5	14.9
L	H	L	H	H	L	11.7	15.2
L	H	L	H	H	H	12	15.4
L	H	H	L	L	L	11.8	15.7
L	H	H	L	L	H	12	16
L	H	H	L	H	L	12.3	16.2
L	H	H	L	H	H	12.7	16.6
L	H	H	H	L	L	12.8	16.7
L	H	H	H	L	H	13.4	17.2
L	H	H	H	H	L	14.2	18
L	H	H	H	H	H	15.8	19.6

To obtain price, delivery, or to place an order contact [MMICSales@rcy.com](mailto:MMICSales@rcy.com)  
 Atlanta Micro Inc., 3720 Davinci Ct, Suite 125, Peachtree Corners, GA 30092 • Phone: (470) 253-7640 • [www.atlantamicro.com](http://www.atlantamicro.com)

# AM3153 – Filter Bank



## Digitally Tunable 6 to 26.5 GHz Bandpass

### State Table (continued)

VA	VB	V3	V2	V1	V0	Typical Cutoff Frequency (GHz)	
						HP cutoff	LP cutoff
H	L	L	L	L	L	15.6	20.2
H	L	L	L	L	H	15.8	20.3
H	L	L	L	H	L	16.0	20.6
H	L	L	L	H	H	16.2	20.9
H	L	L	H	L	L	16.5	21.0
H	L	L	H	L	H	16.7	21.3
H	L	L	H	H	L	17.0	21.7
H	L	L	H	H	H	17.2	22.1
H	L	H	L	L	L	17.5	21.8
H	L	H	L	L	H	17.9	22.2
H	L	H	L	H	L	18.4	22.7
H	L	H	L	H	H	18.9	23.2
H	L	H	H	L	L	19.8	23.7
H	L	H	H	L	H	20.4	24.4
H	L	H	H	H	L	21.3	25.3
H	L	H	H	H	H	22.3	26.4

# AM3153 – Filter Bank

## Digitally Tunable 6 to 26.5 GHz Bandpass



### Typical Performance

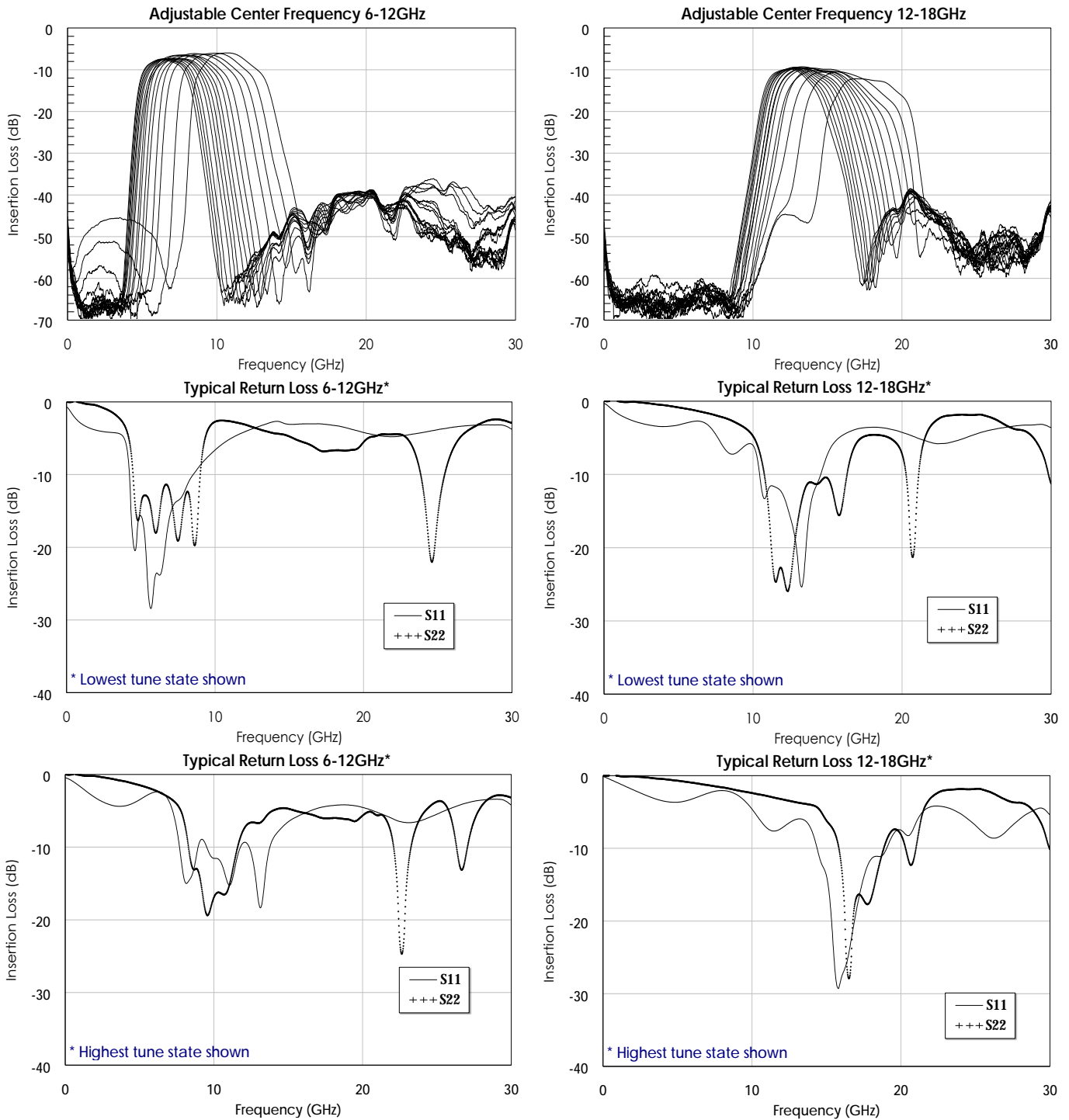

\* Typical values shown for lowest tuned frequency (control bits 0000) or highest tuned frequency (control bits 1111)

### Typical Performance (continued)

To obtain price, delivery, or to place an order contact [MMICSales@rcy.com](mailto:MMICSales@rcy.com)  
 Atlanta Micro Inc., 3720 Davinci Ct, Suite 125, Peachtree Corners, GA 30092 • Phone: (470) 253-7640 • [www.atlantamicro.com](http://www.atlantamicro.com)



# AM3153 – Filter Bank

## Digitally Tunable 6 to 26.5 GHz Bandpass

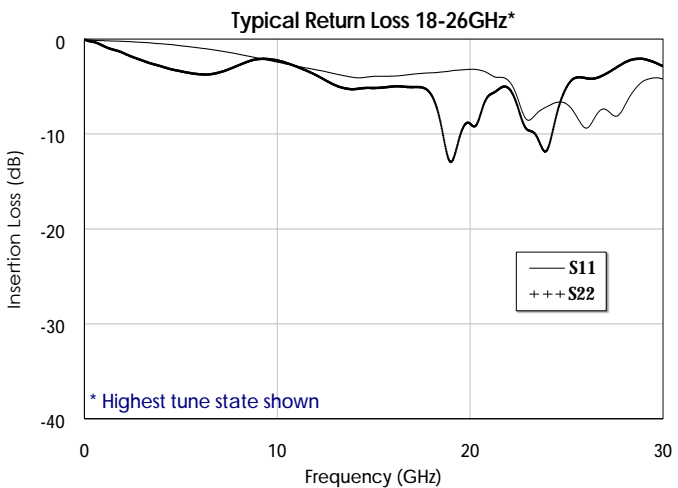
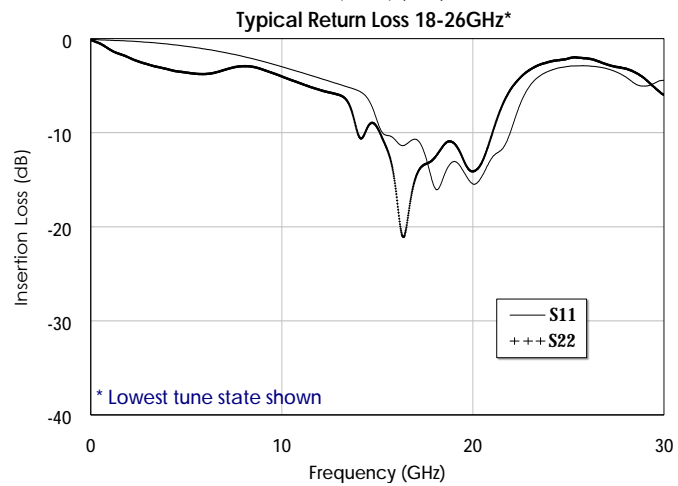
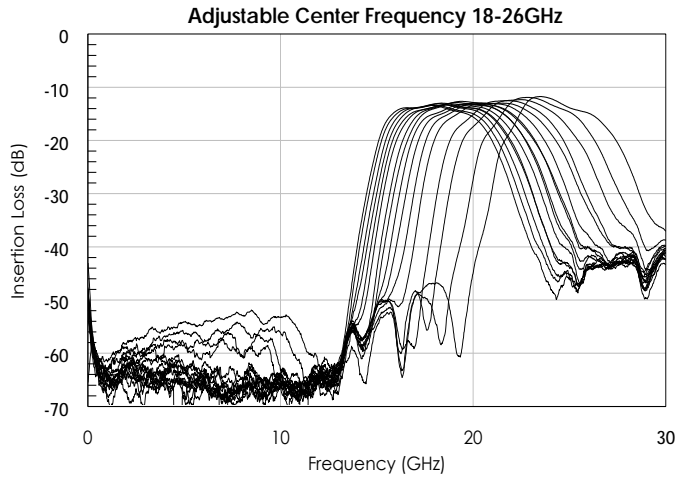

\* Typical values shown for lowest tuned frequency (control bits 0000) or highest tuned frequency (control bits 1111)

# AM3153 – Filter Bank

## Digitally Tunable 6 to 26.5 GHz Bandpass



### Typical Application

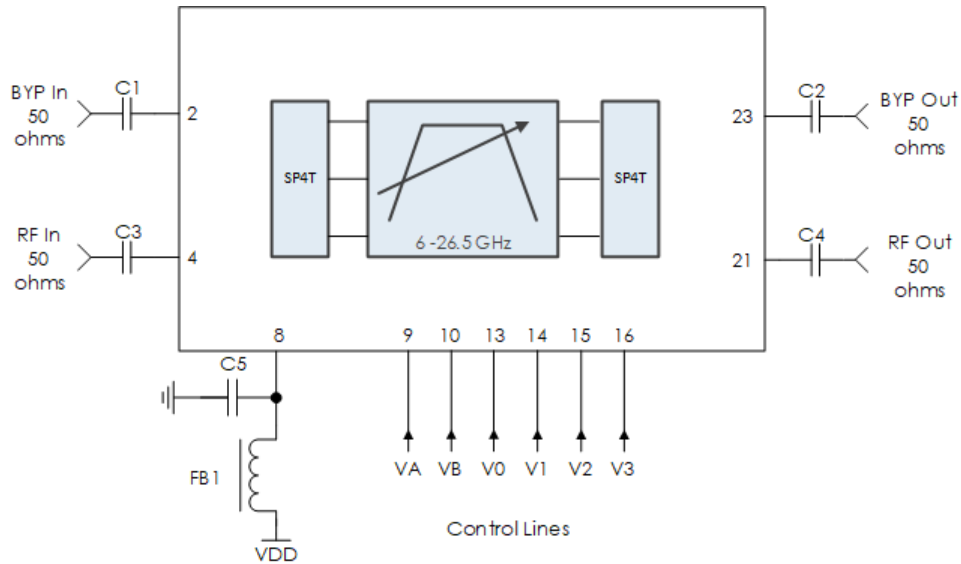

### Recommended Component List (or equivalent):

Part	Value	Part Number	Manufacturer
C1-C4	0.1 $\mu$ F	0201BB104KW160	Passives Plus
FB1	-	MMZ1005A222E	TDK
C5	0.1 $\mu$ F	C1005X7R1H104K050BB	TDK

### Notes:

1. DC blocking capacitors should be high performance, low-loss, broadband capacitors for optimum performance.
2. Control lines are filtered internally providing high frequency isolation.

# AM3153 – Filter Bank

Digitally Tunable 6 to 26.5 GHz Bandpass



## Evaluation PC Board

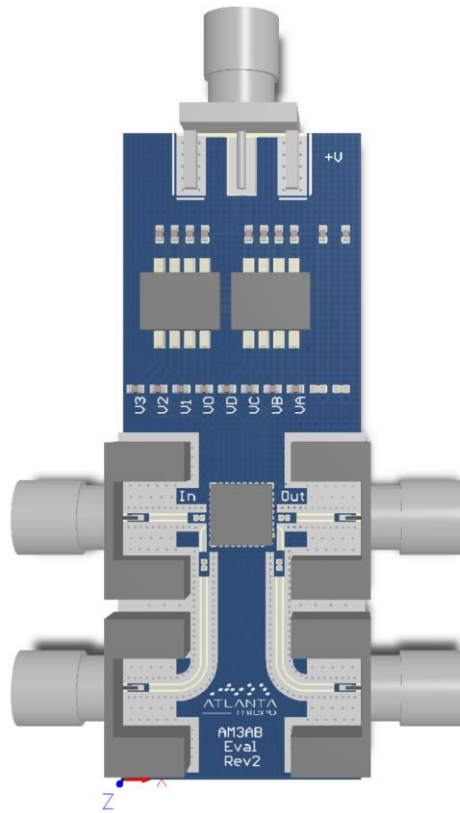

## Related Parts

Part Number	Description
AM3186	6 GHz to 26.5 GHz Suboctave Fixed Bandpass Filter Bank
AM3152	0.4 GHz to 8 GHz Digitally Tunable Bandpass Filter Bank
AM3066	12 GHz to 26.5 GHz Digitally Tunable Bandpass Filter

### Component Compliance Information

**RoHS:** Atlanta Micro, Inc. hereby certifies that all products comply with the EC Directive 2011/65/EC on the Restriction of Hazardous Substances, commonly known as EU-RoHS 6 and 10. All products supplied by Atlanta Micro shall be compliant with the European Directive 2011/65/EC based on the following substance list.

Substance List	Allowable Maximum Concentration
Lead (Pb)	<1000 PPM (0.1% by weight)
Mercury (Hg)	<1000 PPM (0.1% by weight)
Cadmium (Cd)	<75 PPM (0.0075% by weight)
Hexavalent Chromium (CrVI)	<1000 PPM (0.1% by weight)
Polybrominated Biphenyls (PBB)	<1000 PPM (0.1% by weight)
Polybrominated Diphenyl ethers (PBDE)	<1000 PPM (0.1% by weight)
Decabromodiphenyl Deca BDE	<1000 PPM (0.1% by weight)
Bis (2-ethylhexyl) Phthalate (DEHP)	<1000 PPM (0.1% by weight)
Butyl Benzyl Phthalate (BBP)	<1000 PPM (0.1% by weight)
Dibutyl Phthalate (DBP)	<1000 PPM (0.1% by weight)
Diisobutyl Phthalate (DIBP)	<1000 PPM (0.1% by weight)

**REACH:** Atlanta Micro, Inc. neither uses nor intentionally adds any of the substances considered to be a Substance of Very High Concern (SVHC) as defined by the EU Regulation (EC) No. 1907-2006 on Registration, Evaluation, Authorization, and Restriction of Chemicals (REACH).

**Conflict Materials:** Atlanta Micro does not knowingly use materials that are sourced from the Democratic Republic of Congo (DRC) or any other known conflict regions. Atlanta Micro's supply chain is comprised of sources that are both environmentally and socially responsible. We periodically review this requirement with our vendors to ensure continued compliance.

Atlanta Micro takes its responsibility as a global partner seriously and will use due diligence within our supply chain to ensure all standards are met to the best of our knowledge.