

AM1095 – Amplifier

6 to 22.25 GHz Driver Amplifier

Description

The AM1095 is an AC-coupled amplifier covering 6 GHz to 22.25 GHz. The device exhibits high output P1dB performance, relatively low noise figure, and excellent gain stability over the operating temperature range. With internal 50Ω matching and packaged in a 3mm QFN, the AM1095 represents a compact total PCB footprint.

Features

- 18 dB Gain
- 3.5 dB Noise Figure
- +24 dBm OIP3
- +19 dBm P1dB
- +5 V, 136 mA
- 3mm QFN
- -40C to +85C Operation

Functional Diagram

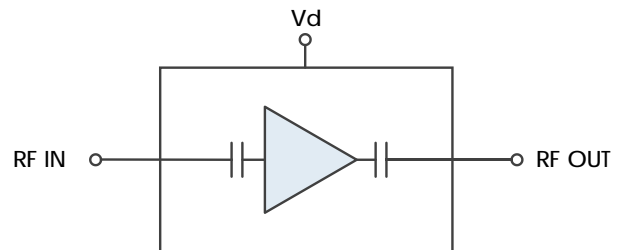

Characteristic Performance

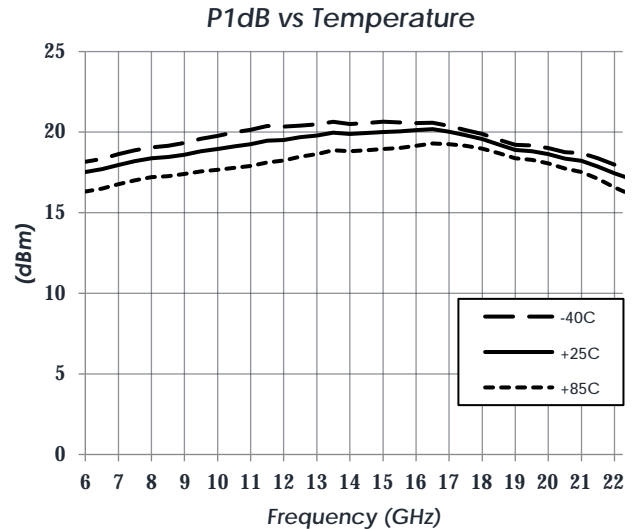
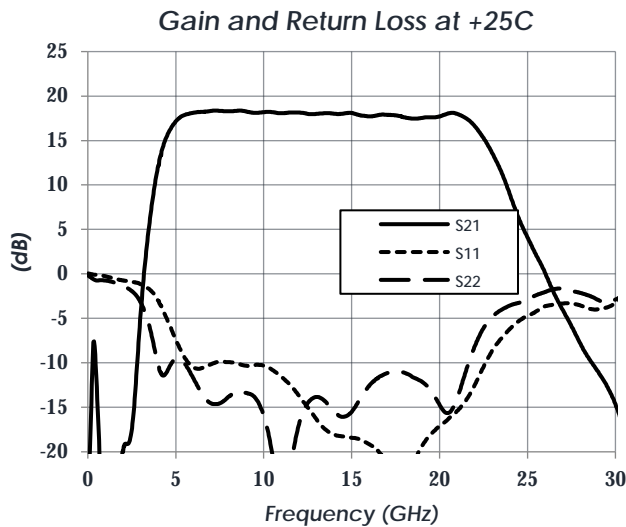

AM1095 – Amplifier

6 to 22.25 GHz Driver Amplifier

Table of Contents

Description	1	Recommended Operating Conditions ...	4
Features.....	1	Thermal Information	4
Functional Diagram.....	1	DC Electrical Characteristics.....	5
Characteristic Performance	1	RF Performance	5
Revision History	2	Typical Performance	6
Pin Layout and Definitions.....	3	Typical Application.....	8
Specifications	4	Evaluation PC Board	9
Absolute Maximum Ratings.....	4	Related Parts.....	9
Handling Information.....	4	Component Compliance Information.....	10

Revision History

Date	Revision Number	Notes
October 5, 2021	1	Initial Release

AM1095 – Amplifier

6 to 22.25 GHz Driver Amplifier

Pin Layout and Definitions

Note: All Un-Labeled Pins are NC or Ground

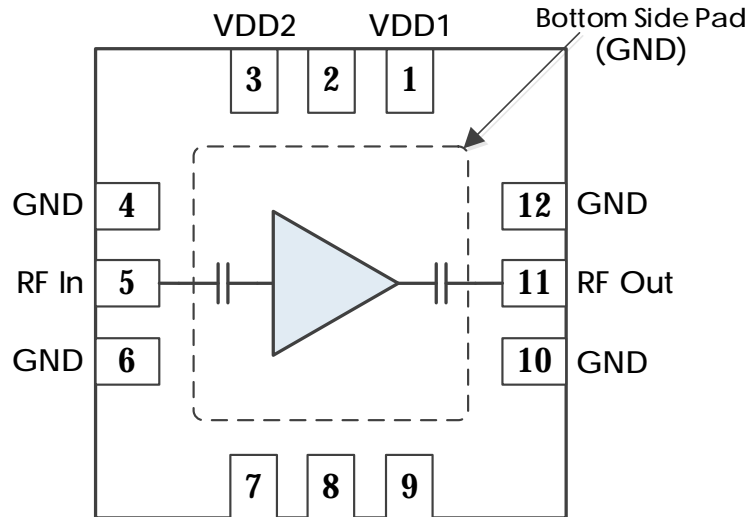

Pin Number	Pin Name	Pin Function
1	VDD1	DC Power Input
2	NC	Not Connected*
3	VDD2	DC Power Input
4	GND	Ground - Common
5	RF In	RF Input – 50 Ohms – AC Coupled.
6	GND	Ground - Common
7-9	NC	Not Connected*
10	GND	Ground - Common
11	RF Out	RF Output – 50 Ohms – AC Coupled.
12	GND	Ground - Common

*NC pins may be grounded or left open

AM1095 – Amplifier

6 to 22.25 GHz Driver Amplifier

Specifications

Absolute Maximum Ratings

	Minimum	Maximum
Device Voltage, Vd	-0.3 V	+4.8 V
RF Input Power		+20 dBm
Operating Junction Temperature	-40 C	+150 C
Storage Temperature Range	-50 C	+150 C

Note: Any device operation beyond the Absolute Maximum Ratings may result in permanent damage to the device. The values listed in this table are extremes and do not imply functional operation of the device at these or any other conditions beyond what is listed under Recommended Operating Conditions. Any part subjected to conditions outside of what is recommended for an extended amount of time may suffer from reliability concerns.

Handling Information

	Minimum	Maximum
Storage Temperature Range (Recommended)	-50 C	+125 C
Moisture Sensitivity Level	MSL 3	



Atlanta Micro products are electrostatic sensitive.
Follow safe handling practices to avoid damage

Recommended Operating Conditions

	Minimum	Typical	Maximum
Supply Voltage, Vsupply	+4.7 V	+5.0 V	+5.2 V
Device Voltage, Vd	+4.1 V	+4.4 V	+4.7 V
Operating Case Temperature	-40 C		+85 C
Operating Junction Temperature	-40 C		+150 C

Thermal Information

	Thermal Resistance (°C / W)
Junction to Case Thermal Resistance (θ_{JC})	87

AM1095 – Amplifier

6 to 22.25 GHz Driver Amplifier

DC Electrical Characteristics

(T = 25 °C unless otherwise specified)

Parameter	Testing Conditions	Minimum	Typical	Maximum
Device Voltage, Vd	Vsupply = +5.0 V	+4.1	+4.4 V	+4.7
DC Supply Current (Total)	VDD1 = VDD2 = +4.4 V		136 mA	
Power Dissipated	VDD1 = VDD2 = +4.4 V		0.6 W	

RF Performance

(T = 25 °C unless otherwise specified)

Parameter	Testing Conditions	Minimum	Typical	Maximum
Frequency Range		6 GHz		22.5 GHz
Gain	VDD = +4.4 V		18 dB	
Return Loss	VDD = +4.4 V		12 dB	
Output IP3	VDD = +4.4 V		24 dBm	
Output P1dB	VDD = +4.4 V		19 dBm	
Output PSat	VDD = +4.4 V		20 dBm	
Noise Figure	VDD = +4.4 V		3.5 dB	

AM1095 – Amplifier

6 to 22.25 GHz Driver Amplifier

Typical Performance

(VDD1 = VDD2 = +4.4 V, I_d = 136 mA)

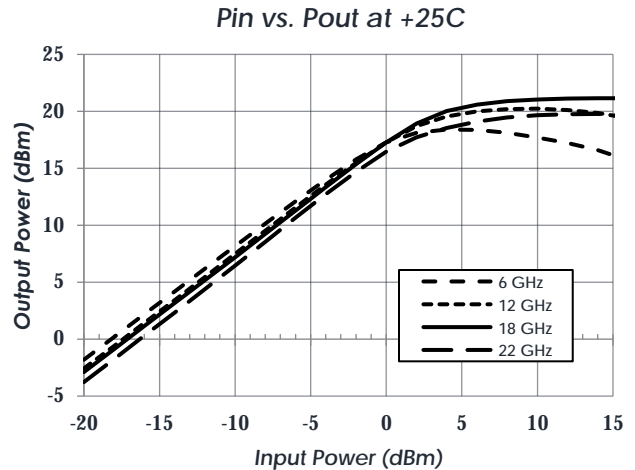
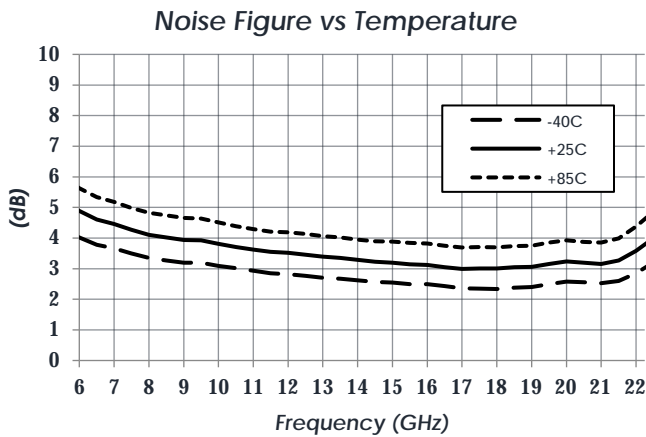
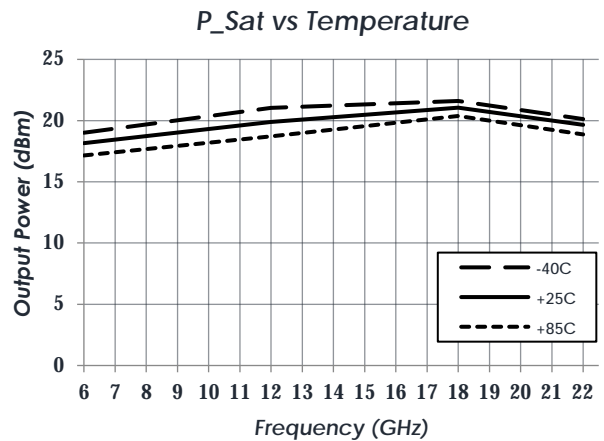
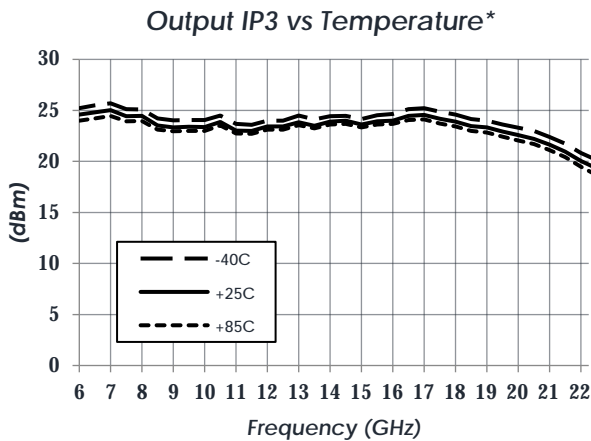
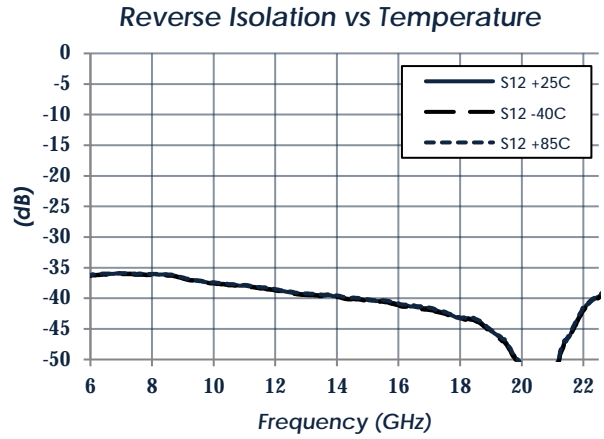
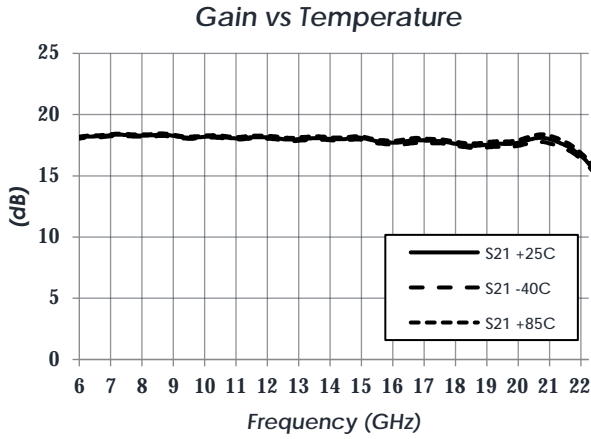

*Note: Measured with 2 tone test; tone spacing 10 MHz

AM1095 – Amplifier

6 to 22.25 GHz Driver Amplifier

Typical Performance (continued)

(VDD1 = VDD2 = +4.4 V, I_d = 136 mA)

Pin vs. Pout at -40C

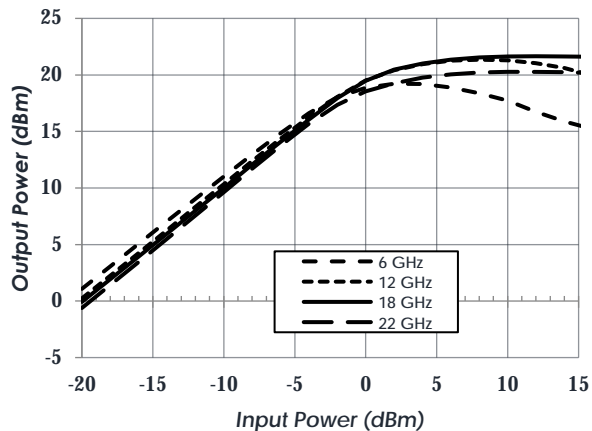

Pin vs. Pout at +85C

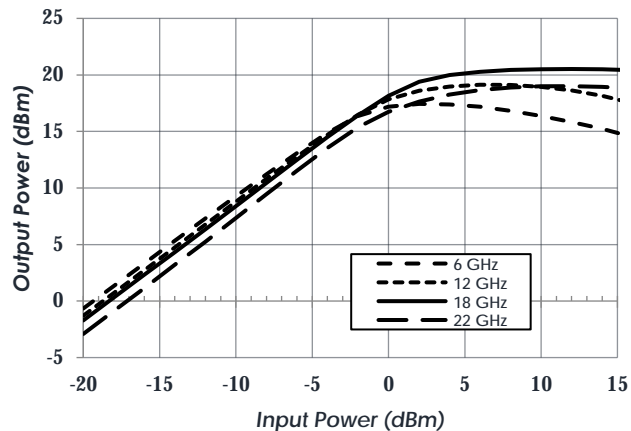

Typical Device Characteristics

(VDD1 = VDD2 = +4.4V, I_d = 136 mA, T = 25°C unless otherwise specified)

Current Distribution

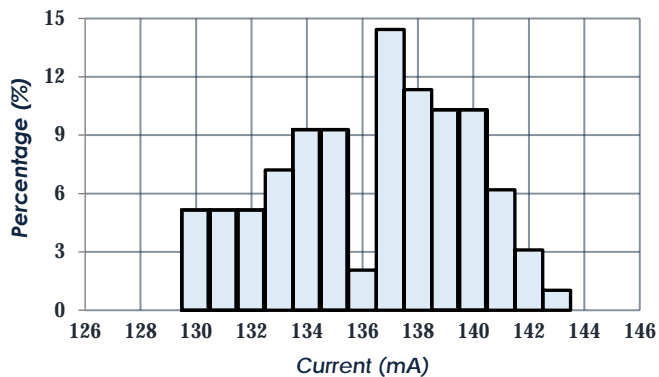

Typical Application

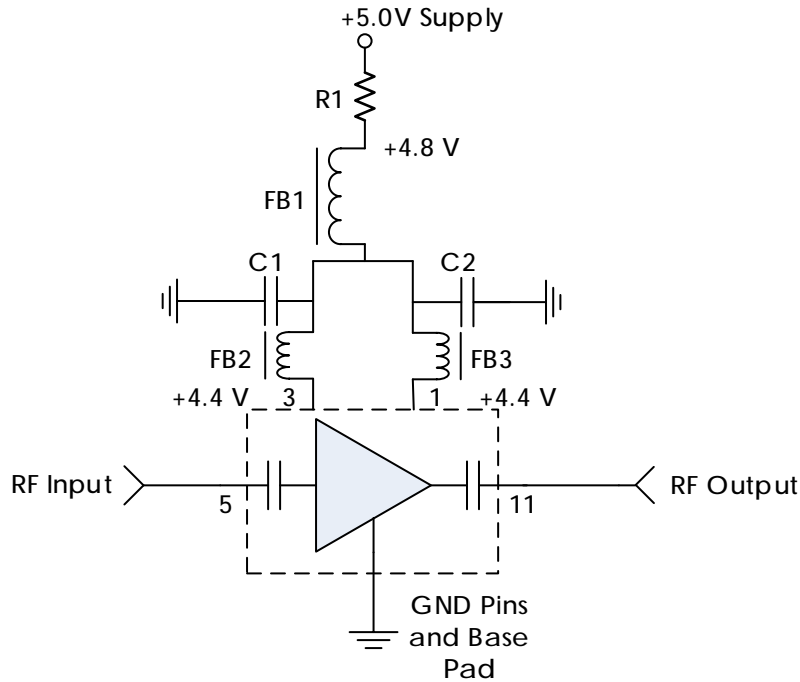

Recommended Component List (or equivalent):

Part	Value	Part Number	Manufacturer
C1, C2	0.1 μ F	GRM155R71C104KA88	Murata
FB1, FB2, FB3	-	MMZ1005A222E	TDK
R1	1.5 ohm	CRCW04021R50FNED	Vishay Dale

Notes:

1. Dropping resistor R1 or a similar component is required.
2. NC pins may be grounded or left open.

AM1095 – Amplifier

6 to 22.25 GHz Driver Amplifier

Evaluation PC Board

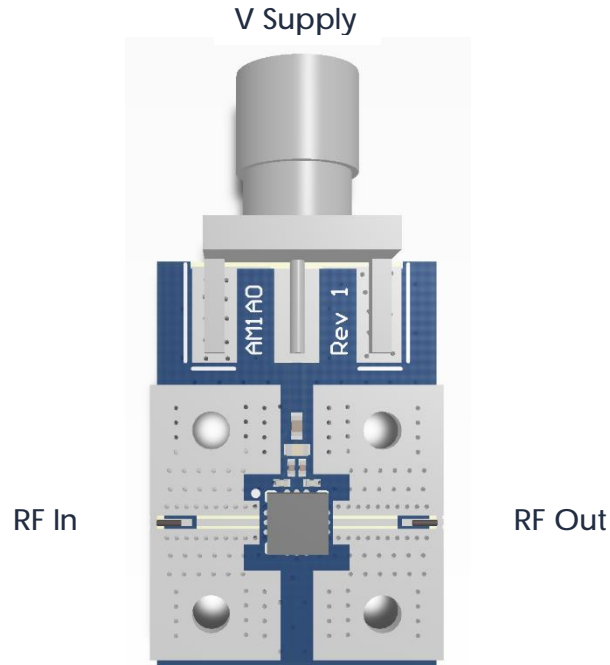

Related Parts

Part Number	Description
AM1053	5 GHz to 20 GHz Gain Block
AM1063	DC to 10 GHz Gain Block
AM1064	DC to 8 GHz Gain Block
AM1065	DC to 8 GHz Bypassable Gain Block
AM1067	5 GHz to 20 GHz Bypassable Gain Block
AM1073	DC to 8 GHz Bi-directional Bypassable Gain Block
AM1077	5 GHz to 20 GHz Bypassable Gain Block w/ Isolation State

Component Compliance Information

RoHS: Atlanta Micro, Inc. hereby certifies that all products comply with the EC Directive 2011/65/EC on the Restriction of Hazardous Substances, commonly known as EU-RoHS 6 and 10. All products supplied by Atlanta Micro shall be compliant with the European Directive 2011/65/EC based on the following substance list.

Substance List	Allowable Maximum Concentration
Lead (Pb)	<1000 PPM (0.1% by weight)
Mercury (Hg)	<1000 PPM (0.1% by weight)
Cadmium (Cd)	<75 PPM (0.0075% by weight)
Hexavalent Chromium (CrVI)	<1000 PPM (0.1% by weight)
Polybrominated Biphenyls (PBB)	<1000 PPM (0.1% by weight)
Polybrominated Diphenyl ethers (PBDE)	<1000 PPM (0.1% by weight)
Decabromodiphenyl Deca BDE	<1000 PPM (0.1% by weight)
Bis (2-ethylhexyl) Phthalate (DEHP)	<1000 PPM (0.1% by weight)
Butyl Benzyl Phthalate (BBP)	<1000 PPM (0.1% by weight)
Dibutyl Phthalate (DBP)	<1000 PPM (0.1% by weight)
Diisobutyl Phthalate (DIBP)	<1000 PPM (0.1% by weight)

REACH: Atlanta Micro, Inc. neither uses nor intentionally adds any of the substances considered to be a Substance of Very High Concern (SVHC) as defined by the EU Regulation (EC) No. 1907-2006 on Registration, Evaluation, Authorization, and Restriction of Chemicals (REACH).

Conflict Materials: Atlanta Micro does not knowingly use materials that are sourced from the Democratic Republic of Congo (DRC) or any other known conflict regions. Atlanta Micro’s supply chain is comprised of sources that are both environmentally and socially responsible. We periodically review this requirement with our vendors to ensure continued compliance.

Atlanta Micro takes its responsibility as a global partner seriously and will use due diligence within our supply chain to ensure all standards are met to the best of our knowledge.