

AM3152 – Filter Bank

Digitally Tunable 0.4 to 8 GHz Bandpass

Description

AM3152 is a miniature digitally tunable bandpass filter bank covering the 0.4 to 8 GHz frequency range. The device exhibits 3 filter bands each with 256 discrete tune states and a low-loss filter bypass path contained in a 6mm QFN package. AM3152 is an excellent front-end for a receiver providing both low insertion loss and valuable flexibility for tuning center frequency and bandwidth. Its small size, weight, and power consumption make it an attractive choice for demanding application requiring low SWaP components.

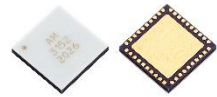

Features

- Digitally Tunable Bandpass Filter
- Integrated Control Line Filtering
- 4.5 dB Insertion Loss
- 8 GHz Filter Bypass Path
- +3.3V to +5.0V Supply
- +3.3V to +5.0V Control
- 6mm QFN Package
- -40C to +85C Operation

Functional Diagram

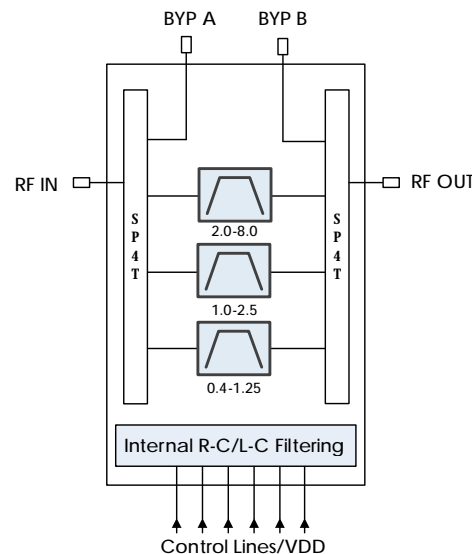

Characteristic Performance

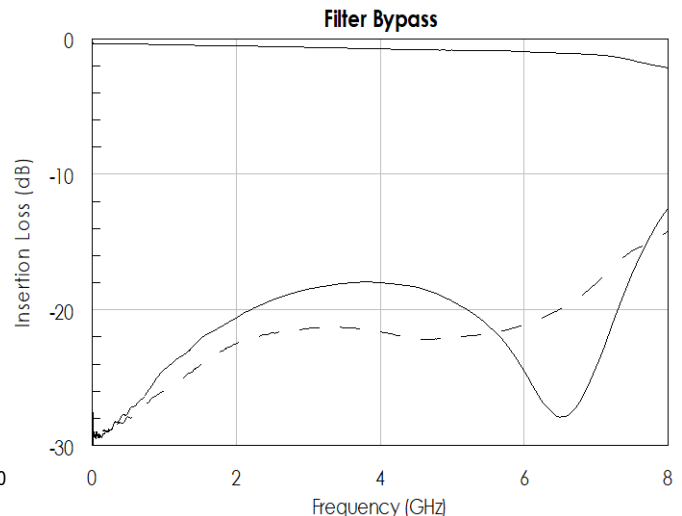
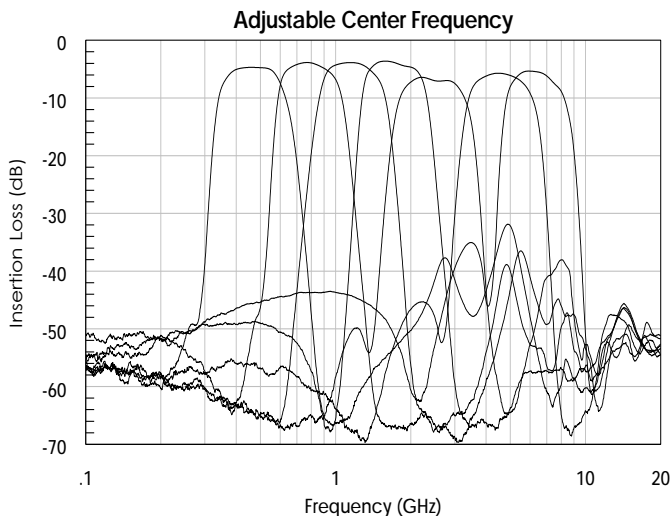

To obtain price, delivery, or to place an order contact MMICSales@mrcty.com
 Atlanta Micro Inc., 3720 Davinci Ct, Suite 125, Peachtree Corners, GA 30092 • Phone: (470) 253-7640 • www.atlantamicro.com

Table of Contents

Description	1	DC Electrical Characteristics.....	6
Features.....	1	RF Performance	6
Functional Diagram.....	1	State Table	6
Characteristic Performance	1	Timing Characteristics	6
Revision History	2	Typical Performance	8
Pin Layout and Definitions.....	3	Typical Application.....	10
Specifications	5	Evaluation PC Board	11
Absolute Maximum Ratings.....	5	Related Parts.....	11
Handling Information.....	5	Component Compliance Information.....	12
Recommended Operating Conditions....	5		

Revision History

Date	Revision Number	Notes
March 30, 2020	0	Preliminary Release
July 13, 2020	0.1	Updated plots, cutoff frequencies, and RF performance
July 21, 2020	1	Initial Release
November 16, 2020	1.1	Updated state table
August 12, 2022	2	Updated Power Handling

AM3152 – Filter Bank



Digitally Tunable 0.4 to 8 GHz Bandpass

Pin Layout and Definitions

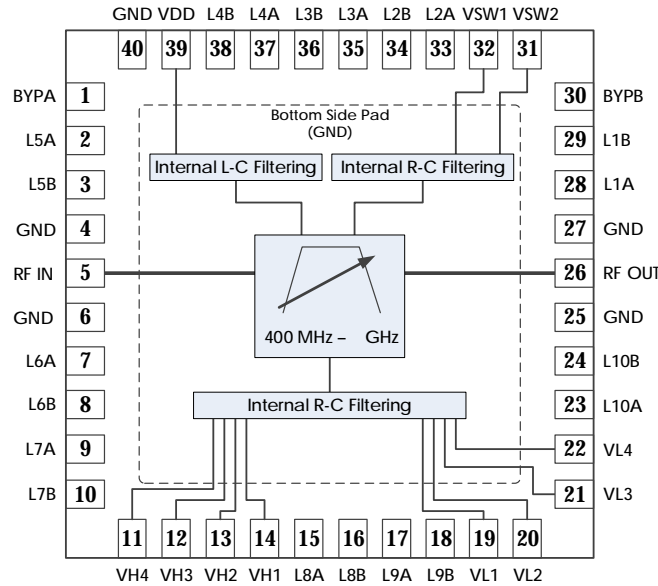

Pin Number	Pin Name	Pin Function
1	BYPA	Filter Bypass Input Side – 50 Ohms – DC Coupled, External DC Block Required
2	L5A	L5 Connection A
3	L5B	L5 Connection B
4	GND	Ground – Common
5	RF IN	RF Input – 50 Ohms – DC Coupled, External DC Block Required
6	GND	Ground – Common
7	L6A	L6 Connection A
8	L6B	L6 Connection B
9	L7A	L7 Connection A
10	L7B	L7 Connection B
11	VH4	Highpass Filter Control Bit 4 (MSB)
12	VH3	Highpass Filter Control Bit 3
13	VH2	Highpass Filter Control Bit 2
14	VH1	Highpass Filter Control Bit 1 (LSB)
15	L8A	L8 Connection A
16	L8B	L8 Connection B
17	L9A	L9 Connection A
18	L9B	L9 Connection B
19	VL1	Lowpass Filter Control Bit 1 (LSB)
20	VL2	Lowpass Filter Control Bit 2
21	VL3	Lowpass Filter Control Bit 3
22	VL4	Lowpass Filter Control Bit 4 (MSB)
23	L10A	L10 Connection A
24	L10B	L10 Connection B

To obtain price, delivery, or to place an order contact MMICSales@mercy.com
 Atlanta Micro Inc., 3720 Davinci Ct, Suite 125, Peachtree Corners, GA 30092 • Phone: (470) 253-7640 • www.atlantamicro.com

AM3152 – Filter Bank



Digitally Tunable 0.4 to 8 GHz Bandpass

Pin Layout and Definitions (continued)

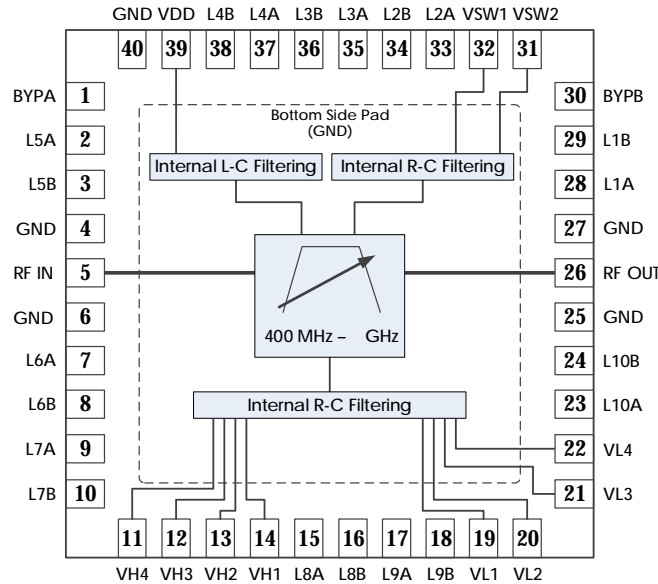

Pin Number	Pin Name	Pin Function
25	GND	Ground – Common
26	RF OUT	RF Output– 50 Ohms – DC Coupled, External DC Block Required
27	GND	Ground – Common
28	L1A	L1 Connection A
29	L1B	L1 Connection B
30	BYPB	Filter Bypass Output Side – 50 Ohms – DC Coupled, External DC Block Required
31	VSW2	Switch Control 2
32	VSW1	Switch Control 1
33	L2A	L2 Connection A
34	L2B	L2 Connection B
35	L3A	L3 Connection A
36	L3B	L3 Connection B
37	L4A	L4 Connection A
38	L4B	L4 Connection B
39	VDD	DC Power Input
40	GND	Ground – Common

AM3152 – Filter Bank



Digitally Tunable 0.4 to 8 GHz Bandpass

Specifications

Absolute Maximum Ratings

	Minimum	Maximum
Supply Voltage	-0.3 V	+6.0 V
RF Input Power (Continuous Wave)		+30 dBm
Operating Junction Temperature	-40 C	+150 C
Storage Temperature Range	-55 C	+150 C

Note: Any device operation beyond the Absolute Maximum Ratings may result in permanent damage to the device. The values listed in this table are extremes and do not imply functional operation of the device at these or any other conditions beyond what is listed under Recommended Operating Conditions. Any part subjected to conditions outside of what is recommended for an extended amount of time may suffer from reliability concerns.

Handling Information

	Minimum	Maximum
Storage Temperature Range (Recommended)	-50 C	+125 C
Moisture Sensitivity Level	MSL 1	



Atlanta Micro products are electrostatic sensitive.
Follow safe handling practices to avoid damage

Recommended Operating Conditions

	Minimum	Typical	Maximum
Supply Voltage	+3.0 V*	+5 V	+5.2 V
Operating Case Temperature	-40 C		+85 C
Operating Junction Temperature	-40 C		+125 C

***Note:** Operating the AM3152 at VDD levels below +5.0V can cause corner frequencies to shift low by up to 2%. It is recommended to use +5.0V when possible. Control voltage level does not affect filter corner frequencies.

AM3152 – Filter Bank

Digitally Tunable 0.4 to 8 GHz Bandpass

DC Electrical Characteristics

(T = 25 °C unless otherwise specified)

Parameter	Testing Conditions	Minimum	Typical	Maximum
DC Supply Voltage		+3.0 V*	+5.0 V	+5.2 V
DC Supply Current	VDD = +5.0 V		10 mA	
Power Dissipated	VDD = +5.0 V		50 mW	
Logic Level Low		-0.1 V		0.5 V
Logic Level High		+2.0 V		+VDD
Logic Drive Level	VSWx/VHx/VLx = +5.0V	200 µA		

*Note: Operating the AM3156 at VDD levels below +5.0V can cause corner frequencies to shift low by up to 2%. It is recommended to use +5.0V when possible. Control voltage level does not affect filter corner frequencies.

RF Performance

(T = 25 °C unless otherwise specified)

Parameter	Testing Conditions	Minimum	Typical	Maximum
Frequency Range		0.4 GHz		8 GHz
Insertion Loss	Band 1		-4 dB	
	Band 2		-3.8 dB	
	Band 3		-6 dB	
Return Loss			-12 dB	

Timing Characteristics

Parameter	Minimum	Typical	Maximum
Band Switching Speed		130 ns	
Band 1 Tuning Speed		430 ns	
Band 2 Tuning Speed		420 ns	
Band 3 Tuning Speed		970 ns	

Note: Timing characteristics measured from 50% control to 90% RF

State Table

SW2	SW1	Filter Band
Low	Low	Bypass State
Low	High	Band 1 – 0.4 to 1.25 GHz
High	Low	Band 2 – 1.0 to 2.5 GHz
High	High	Band 3 – 2.0 to 8.0 GHz

AM3152 – Filter Bank

Digitally Tunable 0.4 to 8 GHz Bandpass

State Table (continued)

High Pass Filter Typical Cutoff Frequencies (GHz)

VH4	VH3	VH2	VH1	Band 1	Band 2	Band 3
Low	Low	Low	Low	0.4	0.94	2.0
Low	Low	Low	High	0.41	0.95	2.01
Low	Low	High	Low	0.42	0.97	2.07
Low	Low	High	High	0.43	0.98	2.09
Low	High	Low	Low	0.45	1.0	2.19
Low	High	Low	High	0.47	1.03	2.21
Low	High	High	Low	0.49	1.06	2.3
Low	High	High	High	0.50	1.09	2.35
High	Low	Low	Low	0.51	1.17	2.77
High	Low	Low	High	0.53	1.18	2.85
High	Low	High	Low	0.56	1.21	3.06
High	Low	High	High	0.6	1.25	3.18
High	High	Low	Low	0.64	1.37	3.63
High	High	Low	High	0.69	1.4	3.88
High	High	High	Low	0.76	1.47	4.65
High	High	High	High	0.85	1.56	5.19

Low Pass Filter Typical Cutoff Frequencies (GHz)

VL4	VL3	VL2	VL1	Band 1	Band 2	Band 3
Low	Low	Low	Low	0.53	1.37	3.0
Low	Low	Low	High	0.54	1.41	3.02
Low	Low	High	Low	0.55	1.45	3.12
Low	Low	High	High	0.56	1.47	3.2
Low	High	Low	Low	0.57	1.51	3.38
Low	High	Low	High	0.59	1.53	3.47
Low	High	High	Low	0.62	1.59	3.63
Low	High	High	High	0.66	1.64	3.76
High	Low	Low	Low	0.75	1.7	4.14
High	Low	Low	High	0.78	1.79	4.31
High	Low	High	Low	0.82	1.91	4.53
High	Low	High	High	0.87	1.98	4.76
High	High	Low	Low	0.92	2.08	5.47
High	High	Low	High	1.02	2.15	5.95
High	High	High	Low	1.15	2.29	6.7
High	High	High	High	1.25	2.4	8.0

Note: State Table cutoff frequencies measured with VDD = 5.0V

AM3152 – Filter Bank

Digitally Tunable 0.4 to 8 GHz Bandpass



Typical Performance

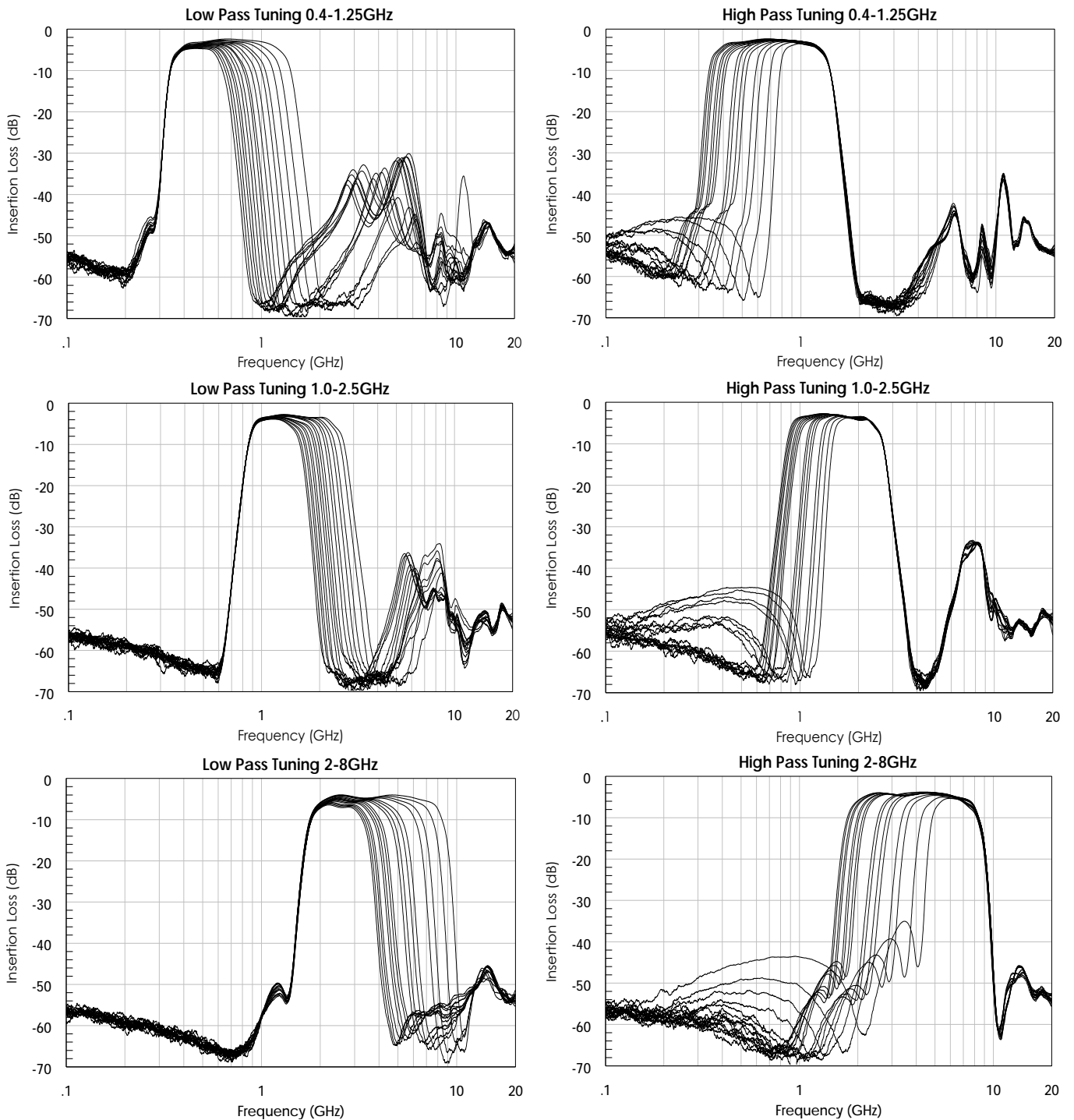

To obtain price, delivery, or to place an order contact MMICSales@mrcty.com
Atlanta Micro Inc., 3720 Davinci Ct, Suite 125, Peachtree Corners, GA 30092 • Phone: (470) 253-7640 • www.atlantamicro.com

AM3152 – Filter Bank

Digitally Tunable 0.4 to 8 GHz Bandpass



Typical Performance (continued)

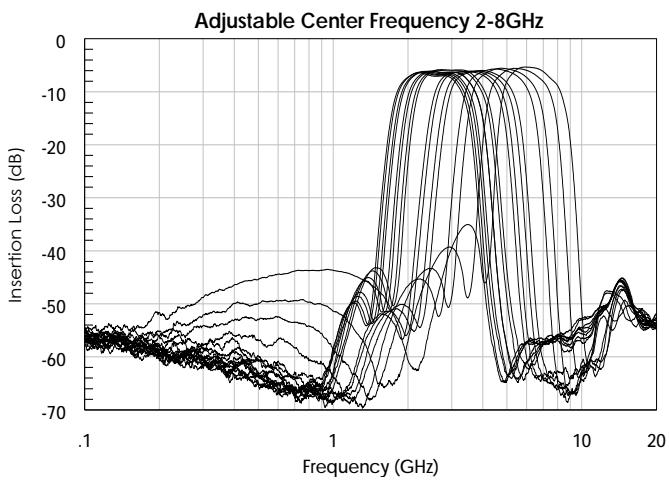
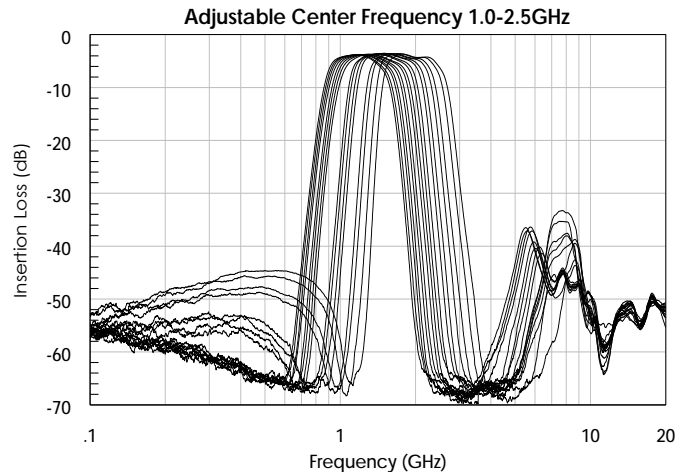
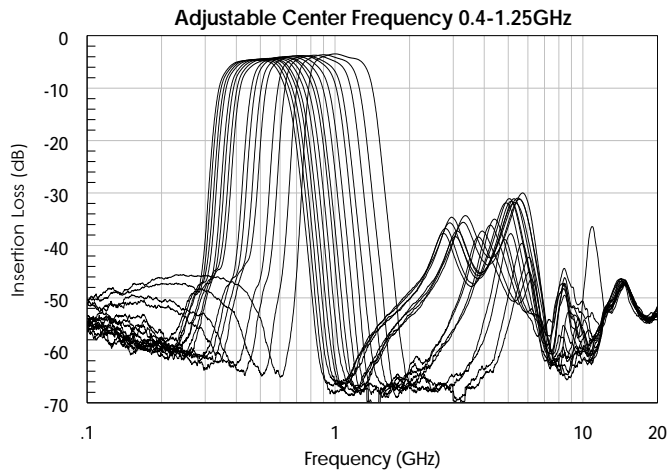

AM3152 – Filter Bank

Digitally Tunable 0.4 to 8 GHz Bandpass

Typical Application

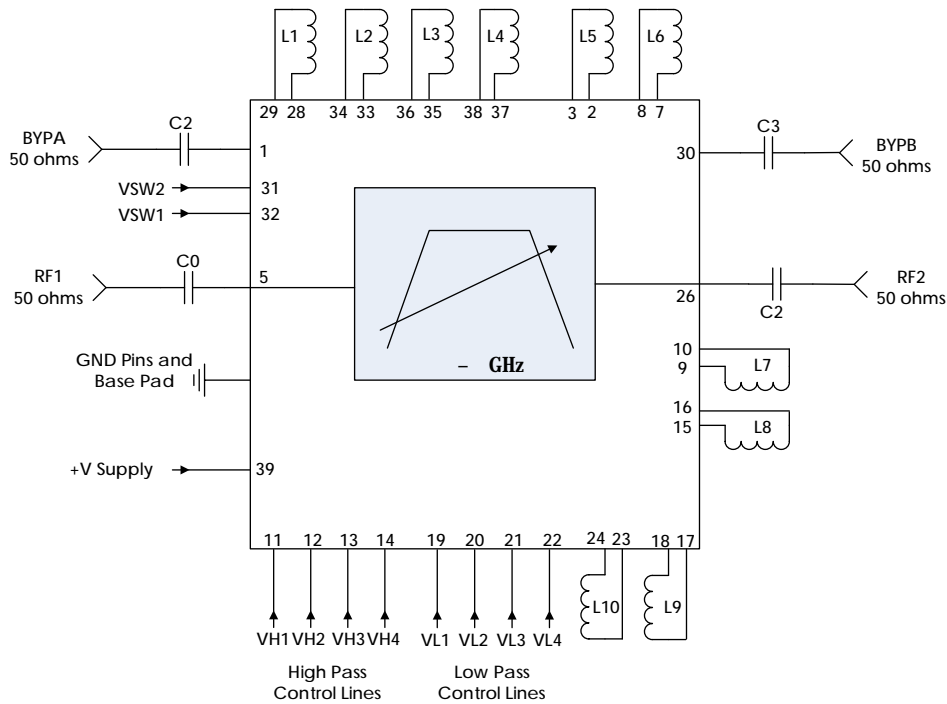

Recommended Component List (or equivalent):

Part	Value	Part Number	Manufacturer
C0 – C3	0.1 uF	0201BB104KW160	Passive Plus
L1	2.0 nH	0402DC-2N0XGRU	Coilcraft
L2	2.8 nH	0402DC-2N8XGRU	Coilcraft
L3, L5	5.1 nH	0402DC-5N1XGRU	Coilcraft
L4	6.7 nH	0402DC-6N7XGRU	Coilcraft
L6, L8	12 nH	0402DC-12NXGRU	Coilcraft
L7	20 nH	0402DC-20NXGRU	Coilcraft
L9	6.6 nH	0402DC-6N6XGRU	Coilcraft
L10	4.7 nH	0402DC-4N7XGRU	Coilcraft

Notes:

1. VDD and Control Lines filtered internally providing high frequency isolation.
2. DC blocking capacitors should be high performance, low-loss, broadband capacitors for optimum performance.

AM3152 – Filter Bank

Digitally Tunable 0.4 to 8 GHz Bandpass

Evaluation PC Board

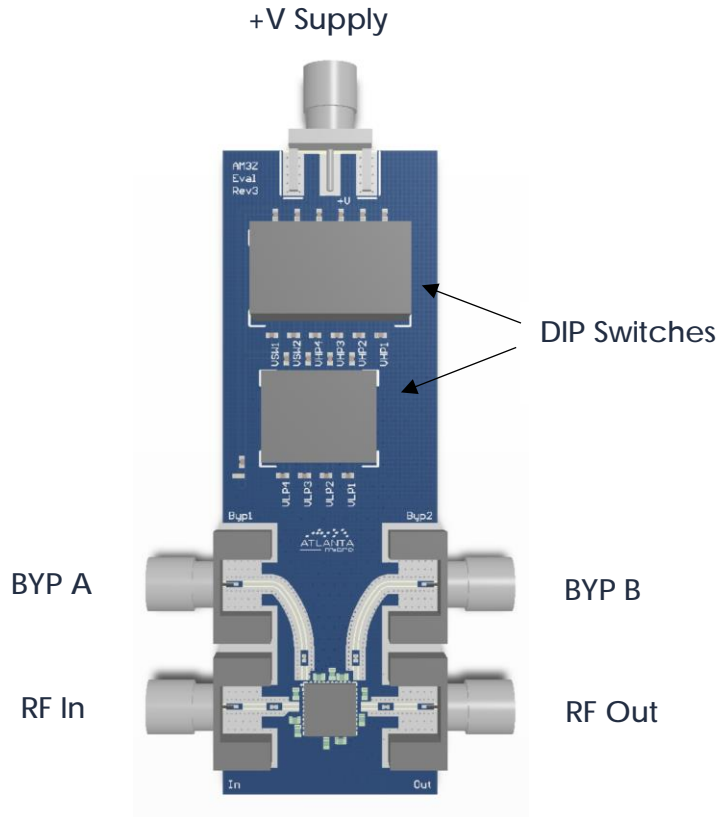

Related Parts

Part Number	Description			
AM3060	0.32 GHz	to	6.5 GHz	Digitally Tunable Bandpass Filter
AM3150	30 MHz	to	550 MHz	Digitally Tunable Low Pass Filter
AM3151	20 MHz	to	360 MHz	Digitally Tunable High Pass Filter
AM3153	6 GHz	to	26.5 GHz	Digitally Tunable Bandpass Filter

Component Compliance Information

RoHS: Atlanta Micro, Inc. hereby certifies that all products comply with the EC Directive 2011/65/EC on the Restriction of Hazardous Substances, commonly known as EU-RoHS 6 and 10. All products supplied by Atlanta Micro shall be compliant with the European Directive 2011/65/EC based on the following substance list.

Substance List	Allowable Maximum Concentration
Lead (Pb)	<1000 PPM (0.1% by weight)
Mercury (Hg)	<1000 PPM (0.1% by weight)
Cadmium (Cd)	<75 PPM (0.0075% by weight)
Hexavalent Chromium (CrVI)	<1000 PPM (0.1% by weight)
Polybrominated Biphenyls (PBB)	<1000 PPM (0.1% by weight)
Polybrominated Diphenyl ethers (PBDE)	<1000 PPM (0.1% by weight)
Decabromodiphenyl Deca BDE	<1000 PPM (0.1% by weight)
Bis (2-ethylhexyl) Phthalate (DEHP)	<1000 PPM (0.1% by weight)
Butyl Benzyl Phthalate (BBP)	<1000 PPM (0.1% by weight)
Dibutyl Phthalate (DBP)	<1000 PPM (0.1% by weight)
Diisobutyl Phthalate (DIBP)	<1000 PPM (0.1% by weight)

REACH: Atlanta Micro, Inc. neither uses nor intentionally adds any of the substances considered to be a Substance of Very High Concern (SVHC) as defined by the EU Regulation (EC) No. 1907-2006 on Registration, Evaluation, Authorization, and Restriction of Chemicals (REACH).

Conflict Materials: Atlanta Micro does not knowingly use materials that are sourced from the Democratic Republic of Congo (DRC) or any other known conflict regions. Atlanta Micro's supply chain is comprised of sources that are both environmentally and socially responsible. We periodically review this requirement with our vendors to ensure continued compliance.

Atlanta Micro takes its responsibility as a global partner seriously and will use due diligence within our supply chain to ensure all standards are met to the best of our knowledge.