

# Flexor 7070-320

2-channel 3 GHz A/D, 2-channel 2.8 GHz D/A  
PCIe board with Virtex-7 FPGA

## Complete radar and software radio interface solution

- Radar and communication receiver and transmitter
- Electronic Warfare transponder
- Waveform signal generator
- Wideband data acquisition
- Remote monitoring
- Sensor interfaces



**Model 7070-320 is a member of the OnyxFX® family of high-performance PCIe baseboards with a Xilinx Virtex-7 FPGA and an available FMC I/O slot.** As an integrated solution, the Model 7070-320 FlexorSet® combines the Model 7070 and the Model 3320 Flexor® FMC as a factory-installed set. The required FPGA IP is installed and the board set is delivered ready for immediate use.

The delivered FlexorSet is a multichannel, high-speed data converter and is suitable for connection to the RF or IF ports of a communications or radar system. Its built-in data capture and signal generator features offer an ideal turnkey solution as well as a platform for developing and deploying custom FPGA- processing IP.

Designed to allow users to optimize data conversion rates and modes for specific application requirements, the FlexorSet provides preconfigured conversion profiles. Users can use these profiles which include: digital downconverter and digital upconverter modes, conversion resolution and A/D and D/A sample rates, or program their own profiles. In addition to supporting PCIe Gen. 3 as a native interface, the Model 7070-320 includes optional copper and optical connections to the FPGA for custom I/O.

### FEATURES

- Includes Xilinx® Virtex®-7 VXT FPGA
- GateXpress® supports dynamic FPGA configuration across PCIe
- Two 3.0 GHz A/Ds
- Two 2.8 GHz D/As
- 4 GB of DDR3 SDRAM
- Sample clock synchronization to an external system reference
- PCI Express (Gen. 1, 2 & 3) interface up to x8
- LVDS connections to the Virtex-7 FPGA for custom I/O
- Optional optical Interface for backplane gigabit serial interboard communication
- Ruggedized and conduction-cooled versions available

## THE FLEXOR ARCHITECTURE

Based on the proven design of the Mercury Onyx family of Virtex-7 products, the 7070 FMC carrier retains all the key features of that family. As a central foundation of the board architecture, the FPGA has access to all data and control paths of both the carrier board and the FMC module, enabling factory-installed functions that include data multiplexing, channel selection, data packing, gating, triggering and memory control.

When delivered as an assembled board set, the 7070-320 includes factory-installed applications ideally matched to the board's analog interfaces. The functions include two A/D acquisition IP modules for simplifying data capture and data transfer.

Each of the acquisition IP modules contains IP for DDR3 SDRAM memories.

The 7070-320 features two sophisticated D/A waveform generator IP modules. A linked-list controller allows users to easily play back to the D/As waveforms stored in either on-board or off-board host memory. Parameters including length of waveform, delay from trigger, waveform repetition, etc. can be programmed for each waveform.

## EXTENDABLE IP DESIGN

For applications that require specialized functions, users can install their own custom IP for data processing. The GateFlow FPGA Design Kits include all of the factory-installed modules as document source code. Developers can integrate their own IP with the factory-installed functions or use the GateFlow kit to completely replace the IP with their own.

## XILINX VIRTEX-7 FPGA

The 7070-320 can be optionally populated with one of two Virtex-7 FPGAs to match the specific requirements of the processing task. Supported FPGAs are VX330T or VX690T. The VX690T features 3600 DSP48E1 slices and is ideal for modulation/demodulation, encoding/decoding, encryption/decryption, and channelization of the signals between transmission and reception. For applications not requiring large DSP resources or logic, the lower-cost VX330T can be installed.

Sixteen pairs of LVDS connections are provided between the FPGA and a card-edge connector for custom I/O.

## GATEXPRESS FOR FPGA CONFIGURATION

The Onyx architecture includes GateXpress<sup>®</sup>, a sophisticated FPGA-PCIe configuration manager for loading and reloading the FPGA. At power up, GateXpress immediately presents a PCIe target for the host computer to discover, effectively giving the FPGA time to load from FLASH. This is especially important for larger FPGAs where the loading times can exceed the PCIe discovery window, typically 100 msec on most PCs.

The board's configuration FLASH can hold four FPGA images. Images can be factory-installed IP or custom IP created by the user, and programmed into the FLASH via JTAG using Xilinx iMPACT or through the board's PCIe interface. At power up the user can choose which image will load based on a hardware switch setting. Once booted, GateXpress allows the user three options for dynamically reconfiguring the FPGA with a new IP image:

- The first is the option to load an alternate image from FLASH through software control. The user selects the desired image and issues a reload command.
- The second option is for applications where the FPGA image must be loaded directly through the PCIe interface. This is important in security situations where there can be no latent user image left in nonvolatile memory when power is removed. In applications where the FPGA IP may need to change many times during the course of a mission, images can be stored on the host computer and loaded through PCIe as needed.
- The third option, typically used during development, allows the user to directly load the FPGA through JTAG using Xilinx iMPACT.

In all three FPGA loading scenarios, GateXpress handles the hardware negotiation simplifying and streamlining the loading task. In addition, GateXpress preserves the PCIe configuration space allowing dynamic FPGA reconfiguration without a host computer reset to rediscover the board. After the reload, the host simply continues to see the board with the expected device ID.

7070-320 BLOCK DIAGRAM

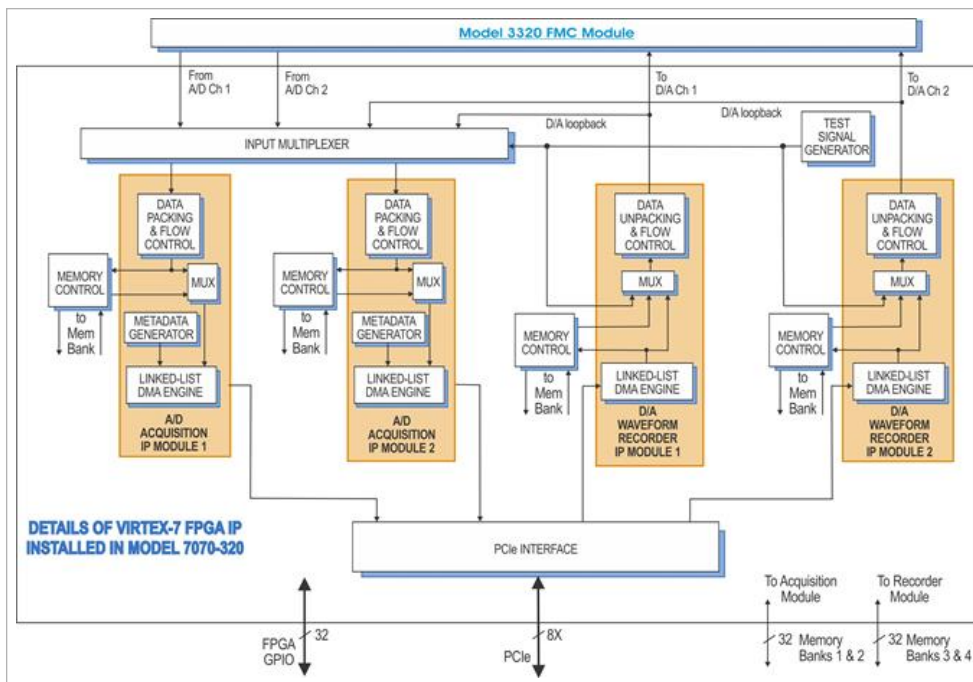
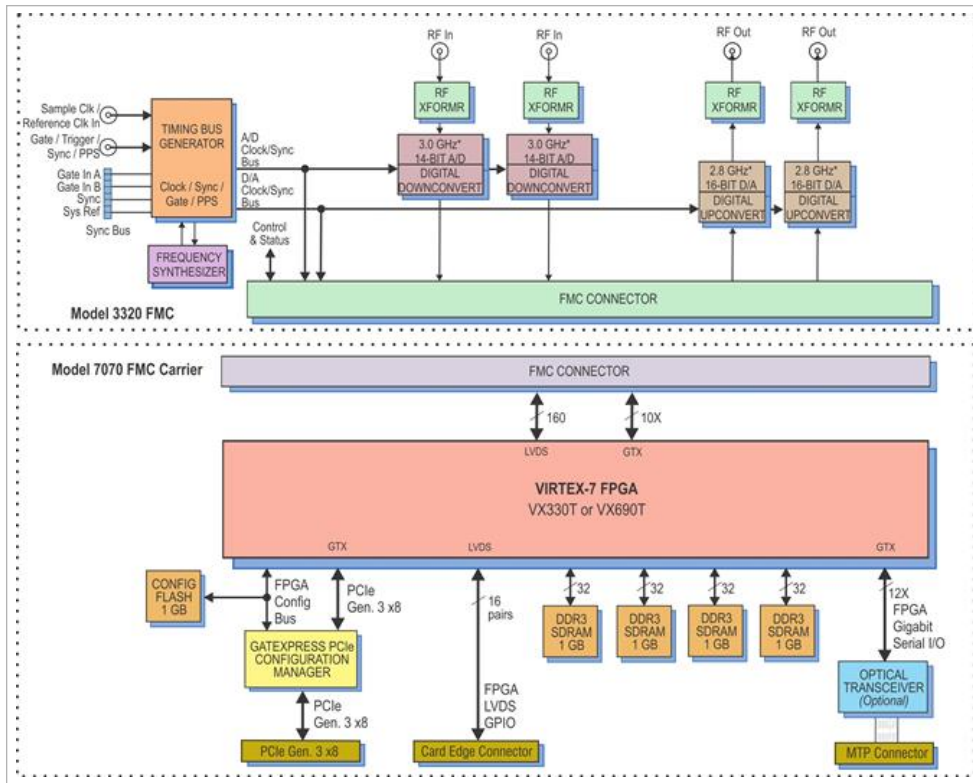

## A/D CONVERTER AND DIGITAL DOWNCONVERTER STAGE

The board's analog interface accepts two analog RF or IF inputs on front-panel connectors with transformer-coupling into a Texas Instruments ADC32RF45 dual channel A/D. With dual built-in digital downconverters and programmable decimations, the converter serves as an ideal interface for a range of radar, signal intelligence and electronic countermeasures applications. The ADC32RF45 can operate within a range of different conversion speeds and resolutions. See "Preconfigured Conversion Modes" on page 7 for supported modes.

## A/D ACQUISITION IP MODULES

The 7070-320 features two A/D Acquisition IP Modules for easy capture and data moving. Each IP module can receive data from any of the two A/Ds, a test signal generator or from the two D/A Waveform Generator IP modules in loopback mode.

Each IP module has an associated memory bank for buffering data in FIFO mode or for storing data in transient capture mode. All memory banks are supported with DMA engines for moving A/D data through the PCIe interface.

These powerful linked-list DMA engines are capable of a unique Acquisition Gate Driven mode. In this mode, the length of a transfer performed by a link definition need not be known prior to data acquisition; rather, it is governed by the length of the acquisition gate. This is extremely useful in applications where an external gate drives acquisition and the exact length of that gate is not known or is likely to vary.

For each transfer, the DMA engine can automatically construct metadata packets containing A/D channel ID, a sample accurate time stamp, and data length information. These actions simplify the host processor's job of identifying and executing on the data.

## D/A WAVEFORM GENERATOR IP MODULE

The 7070-320 factory-installed functions include two sophisticated D/A Waveform Generator IP modules. A linked-list controller allows users to easily record waveforms stored in either onboard or off-board host memory to the two D/As.

Parameters including length of waveform, delay from trigger, waveform repetition, etc. can be programmed for each waveform. Up to 64 individual link entries per module can be chained together to create complex waveforms with a minimum of programming.

## CLOCKING AND SYNCHRONIZATION

An internal timing bus provides all timing and synchronization required by the A/D converters. Included are a clock, sync and gate or trigger signals. An on-board clock generator can receive an external sample clock from the front-panel coaxial connector. This clock can be used directly by the A/D section or divided by a built-in clock synthesizer circuit.

In an alternate mode, the sample clock can be sourced from an on-board programmable VCXO (Voltage-Controlled Crystal Oscillator). In this mode, the front-panel coaxial connector can be used to provide a 10 MHz reference clock for synchronizing the internal oscillator.

A front panel Gate/Trigger/PPS connector can receive an external timing signal allowing multiple boards to be synchronized to create larger multiboard systems.

## MEMORY RESOURCES

The 7070-320 architecture supports four independent DDR3 SDRAM memory banks. Each bank is 1 GB deep and is an integral part of the board's waveform playback capabilities, providing local storage for user waveforms.

## PCI EXPRESS INTERFACE

The Model 7070-320 includes an industry-standard interface fully compliant with PCI e Gen. 1, 2 and 3 bus specifications. Supporting PCIe links up to x8, the interface includes multiple DMA controllers for efficient transfers to and from the board.

**READYFLOW**

Mercury provides ReadyFlow<sup>®</sup> BSPs (Board Support Packages) for all Cobalt, Onyx, and Flexor products. Available for both Linux and Windows, these packages:

- Provide a path for quick start-up through application completion
- Allow programming at high, intermediate and low levels to meet various needs
- Are illustrated with numerous examples
- Include complete documentation and definitions of all functions
- Include library and example source code.

ReadyFlow BSPs contain C-language examples that can be used to demonstrate the capabilities of Cobalt, Onyx, and Flexor products. These programming examples will help you get an immediate start on writing your own application. They provide sample code that is known to work, giving you a means of verifying that your board set is operational.

**COMMAND LINE INTERFACE**

The Command Line Interface provides access to pre-compiled executable examples that operate the hardware right out of the box, without the need to write any code. Board-specific hardware

operating arguments can be entered in the command line to control parameters: number of channels to enable, sample clock frequency, data transfer size, reference clock frequency, reference clock source, etc.

The Command Line Interface can be used to call an example application from within a larger user application to control the hardware, and parameter arguments are passed to the application for execution. Functions that control data acquisition automatically save captured data to a pre-named host file or are routed to the Signal Analyzer example function for display.

**SIGNAL ANALYZER**

When used with the Command Line Interface, the Signal Analyzer allows users to immediately start acquiring and displaying A/D data. A full-featured analysis tool, the Signal Analyzer displays data in time and frequency domains. Built-in measurement functions display 2nd and 3rd harmonics, THD, and SINAD. Interactive cursors allow users to mark data points and instantly calculate amplitude and frequency of displayed signals.

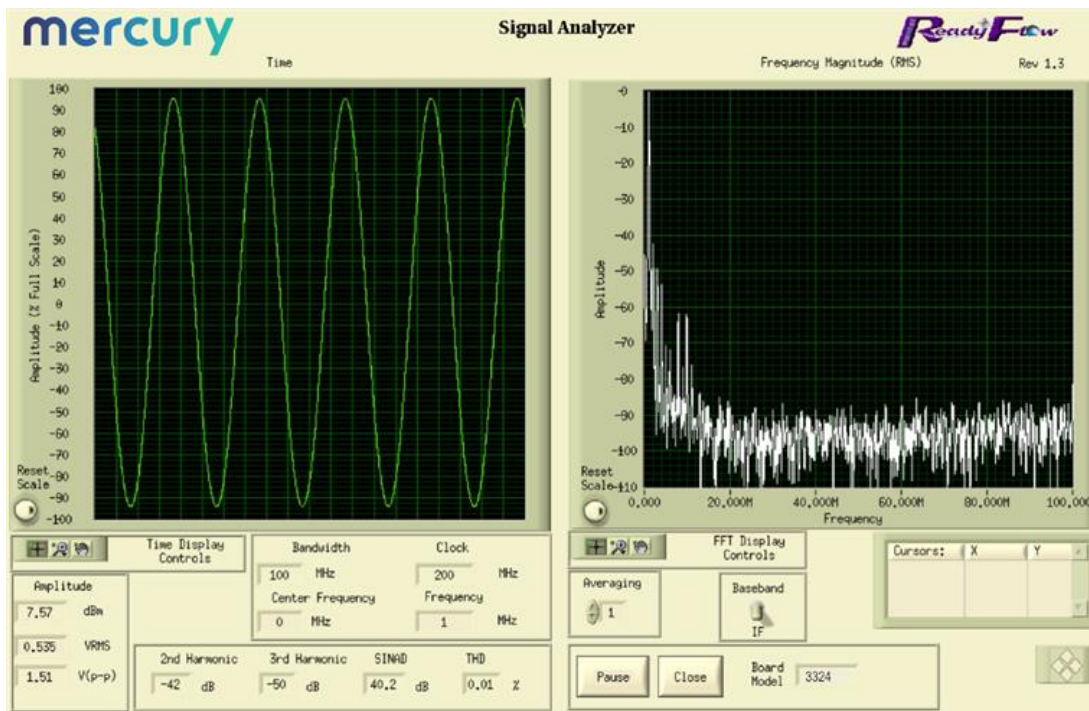

**GATEFLOW**

The GateFlow<sup>®</sup> FPGA Design Kit (FDK) allows the user to modify, replace and extend the standard installed functions in the FPGA to incorporate special modes of operation, new control structures, and specialized signal-processing algorithms.

The Cobalt (Virtex-6), Onyx (Virtex-7), and Flexor (Virtex-7) architectures configure the FPGA with standard factory-supplied interfaces including memory controllers, DMA engines, A/D and D/A interfaces, timing and synchronization structures, triggering and gating logic, time stamping and header tagging, data formatting engines, and the PCIe interface. These resources are connected to the User Application Container using well-defined ports that present easy-to-use data and control signals, effectively abstracting the lower-level details of the hardware.

**The User Application Container**

Shown below is the FPGA block diagram of a typical Cobalt, Onyx or Flexor module. The User Application Container holds a collection of different installed IP modules connected to the various interfaces through the standard ports surrounding the container. The specific IP modules for each product are described in further detail in the datasheet of that product.

The GateFlow FDK provides a complete Xilinx's ISE or Vivado project folder containing all the files necessary for the FPGA developer to recompile the entire project with or without any required changes. VHDL source code for each IP module provides excellent examples of how the IP modules work, how they might be modified, and how they might be replaced with custom IP to implement a specific function.

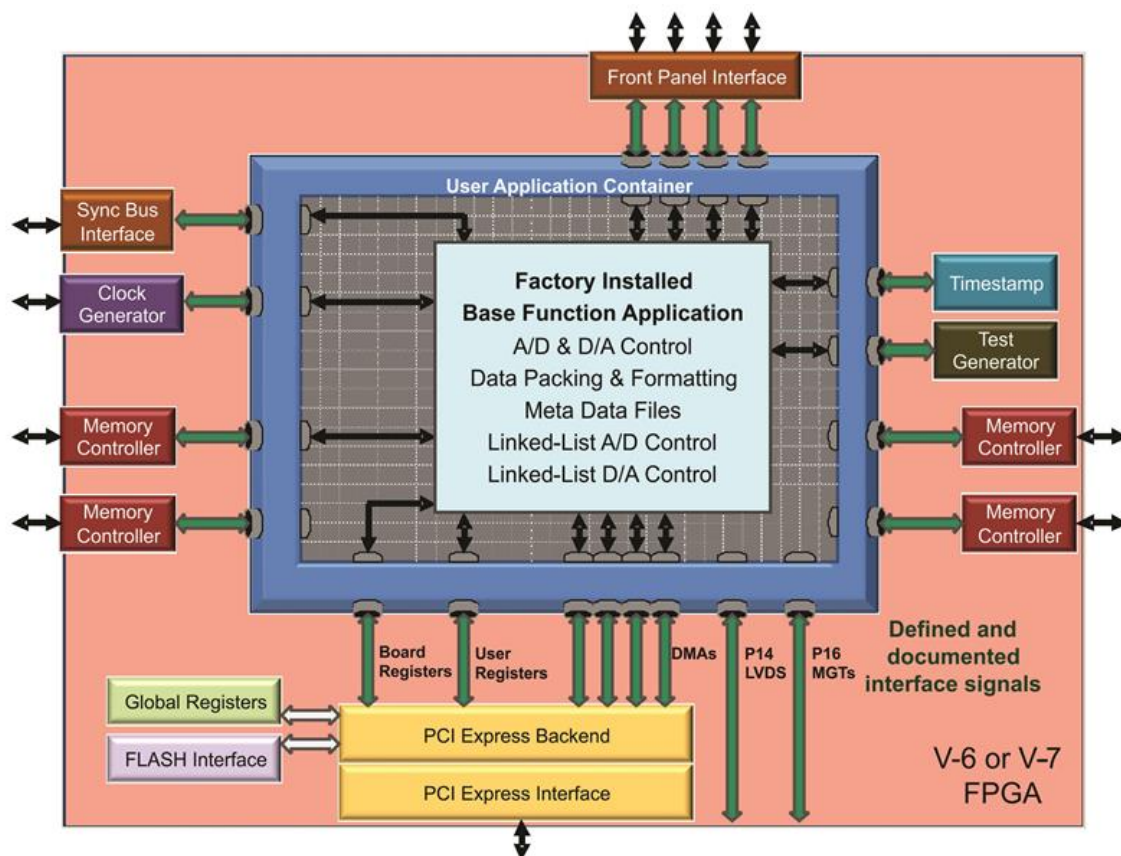

**PRECONFIGURED CONVERSION MODES**

When the Model 3320 is part of a FlexorSet, it is delivered with a set of six preconfigured modes. These allow users to easily select A/D and D/A settings that are commonly used in many applications. While these modes typically satisfy many applications, users can always configure the A/D and D/A settings to their specific requirements via the PCIe interface using the ReadyFlow Board Support Package.

**A/D CONVERTER**

mode	sample rate	DDC or bypass	output bits resolution	output bandwidth	real or complex	output data rate/chan	usable bandwidth
1	3.0 GHz	dec = 4	16 I + 16 Q	600 MHz	complex	3.0 GB/sec	600 MHz
2	2.8 GHz	dec = 4	16 I + 16 Q	560 MHz	complex	2.8 GB/sec	560 MHz
3	2.8 GHz	dec = 4	16 I + 16 Q	560 MHz	complex	2.8 GB/sec	560 MHz
4	2.5 GHz	bypass	12	2.5 GHz	real	5.0 GB/sec	1000 MHz
5	2.0 GHz	bypass	14	2.0 GHz	real	4.0 GB/sec	800 MHz
6	2.0 GHz	bypass	14	2.0 GHz	real	4.0 GB/sec	800 MHz

**D/A CONVERTER**

mode	sample rate	DDC or bypass	input bits resolution	real or complex	output data rate/chan	usable bandwidth
1	-	-	-	-	-	-
2	2.8 GHz	int = 2	16 I + 16 Q	complex	5.6 GB/sec	1120 MHz
3	2.8 GHz	int = 4	16 I + 16 Q	complex	2.8 GB/sec	560 MHz
4	-	-	-	-	-	-
5	2.0 GHz	int = 2	16 I + 16 Q	complex	4.0 GB/sec	800 MHz
6	2.0 GHz	int = 2	16	real	2.0 GB/sec	400 MHz

**RATIONALE FOR EACH MODE**

- Mode 1: Maximum A/D sample rate of 3 GS/s, but the DDC must be used. D/A cannot operate at this sample rate.
- Mode 2: Maximum sample rate for A/D and D/A both operating. DDC and DUC must be used, but D/A can generate twice the bandwidth of the A/D bandwidth.
- Mode 3: Maximum sample rate for A/D and D/A both operating (like Mode 2), but now A/D and D/A bandwidths are the same.
- Mode 4: Maximum A/D useable bandwidth achieved with DDC bypass (RAW) output data and 12 bit resolution. D/A cannot operate in this mode.
- Mode 5: Maximum useable signal bandwidth with A/D and D/A both operating. A/D is in bypass with 14-bit resolution. D/A uses DUC with interpolation of 2.
- Mode 6. Like Mode 5 except D/A interpolates real samples instead of complex samples resulting in 400 MHz bandwidth and a simpler output anti-aliasing filter.

**GENERAL NOTES**

1. "Useable bandwidth" is equal to 80% of the Nyquist bandwidth.
2. Anti-aliasing filters are required for A/D inputs and D/A outputs to ensure elimination of unwanted out-of-band signals per Nyquist criteria.
3. Data rates shown are for the interfaces between the FMC module and the FPGA of the FMC carrier for each channel.
4. By changing board-support software, other operating modes are possible, including different decimations and interpolation.
5. The sample rates shown for each mode are the maximum rates for that mode, but lower rates are also supported with other parameters scaled appropriately.
6. Only one mode is allowed at a time, which defines operations for both A/D and D/A.



**FRONT PANEL CONNECTIONS**

The FMC front panel includes six SSMC coaxial connectors, and a 19-pin µSync connector for input/output of timing and analog signals. The front panel also includes seven LEDs.

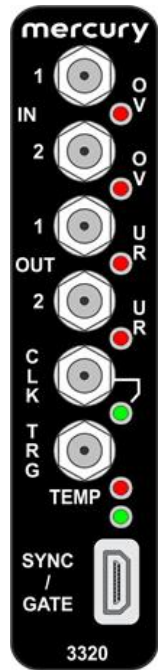

- **Analog Input Connectors:** Two SSMC coaxial connector, labeled **IN 1** and **2** one for each ADC input channel to the ADC32RF45.
- **ADC Overload LEDs:** The two red **OV** (overload) LEDs indicate either an overload in the associated ADC32RF45 or an ADC FIFO overrun.
- **Analog Output Connectors:** Two SSMC coaxial connectors, labeled **OUT 1** and **2** one for each ADC32RF45 output.
- **DAC Underrun LEDs:** There are two red **UR** underrun LEDs, one for each DAC output channel. The red underrun LED illuminates when the associated DAC5688 FIFO is out of data.
- **Clock Input Connector:** One SSMC connector, labeled **CLK** for the input of an external sample clock.
- **Clock LED:** The green **EXT CLK IN** LED illuminates when a valid sample clock signal is detected. If the LED is not illuminated, no clock has been detected and no data from the input stream can be processed.
- **Trigger Input Connector:** One SSMC coaxial connector labeled **TRG** for input of an external trigger.
- **Over Temperature LED:** The red **TMP** LED illuminates when an over-temperature or over-voltage condition is indicated by any of the temperature/voltage sensors on the PCB.
- **User LED:** The green unlabeled LED below the **TEMP** LED is for user applications.
- **Sync Bus Connector:** The 19-pin Sync Bus front panel connectors labeled **SYNC/GATE** provides sync and gate input signals for the Sync Bus.

**FRONT PANEL CONNECTIONS**

The 7070 carrier PCIe slot panel houses the front panel of the 3320 FMC module installed on the carrier. It includes three LED indicators and an optional PPS IN or Optical I/O connector.

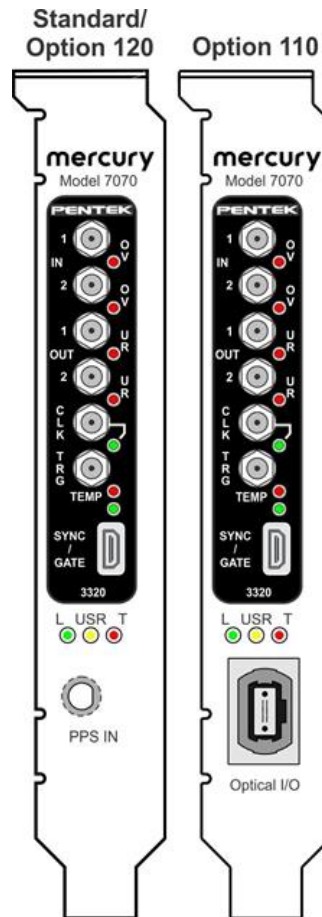

- **LINK LED:** The green **LNK (L)** LED illuminates when a valid PCIe link has been established over the PCIe interface.
- **User LED:** The yellow **USR** LED is available for user applications.
- **Over Temperature LED:** The red **(T)** LED illuminates when an over-temperature or over-voltage condition is indicated by any of the temperature/voltage sensors on the model.
- **PPS Input Connector** (Option 120 only): With Option 120, a PPS IN connector on the standard front panel provides input of an external PPS or Sync signal. Without Option 120, the PPS IN connector is not active and is covered with a plug, as indicated by the dotted circle in the illustration.

**SPECIFICATIONS****Front Panel Analog Signal Inputs**

Input Type: Transformer-coupled, front panel SSMC connectors

Transformer Type: Mini-Circuits TC1-1-13M

Full Scale Input: +6.6 dBm into 50 ohms

3 dB Passband: 4.5 to 3000 MHz

**A/D Converters**

Type: Texas Instruments ADC32RF45

Sampling Rate and Resolution: See the 3320 preconfigured modes table

**Front Panel Analog Signal Outputs**

Output Type: Transformer-coupled, front panel SSMC connectors

Transformer Type: Coil Craft WBC4-14L

Full-Scale Output: +4 dBm into 50 ohms

3 dB Passband: 1.5 MHz to 1200 MHz

**D/A Converters**

Type: Texas Instruments DAC39J84

Sampling Rate and Resolution: See the 3320 preconfigured modes table

**Sample Clock Sources**

Timing bus generator provides A/D and D/A clocks

**Timing Bus Generator**

Clock Source: Selectable from on-board frequency synthesizer or front panel external clock

Synchronization: Frequency synthesizer can be locked to an external 10 MHz PLL system reference

**External Clock**

Type: Front panel SSMC connector, sine wave, 0 to +10 dBm, AC-coupled, 50 ohms

**External Trigger Input**

Type: Front panel SSMC connector

Function: Programmable functions include: trigger, gate, sync and PPS

**Field Programmable Gate Array**

Standard: Xilinx Virtex-7 XC7VX330T-2

Option -076: Xilinx Virtex-7 XC7VX690T-2

**Custom FPGA I/O**

Parallel: 16 pairs of LVDS connections between the FPGA and a card-edge connector for custom I/O

Optical (Option -110): User configurable VITA-66.4, 12X (with VX690T) or 4X (with VX330T) duplex lanes

**Memory**

Type: DDR3 SDRAM

Size: Four banks, 1 GB each

Speed: 800 MHz (1600 MHz DDR)

**PCI-Express Interface**

PCI Express Bus: Gen. 1, 2 or 3: x4 or x8

**Environmental**

Standard: L0 (air-cooled)

- Operating Temp: 0° to 50° C
- Storage Temp: -20° to 90° C
- Relative Humidity: 0 to 95%, non-condensing

Option -702: L2 (air-cooled)

- Operating Temp: -20° to 65° C
- Storage Temp: -40° to 100° C
- Relative Humidity: 0 to 95%, non-condensing

Option -763: L3 (conduction-cooled)

- Operating Temp: -40° to 70° C
- Storage Temp: -50° to 100° C
- Relative Humidity: 0 to 95%, non-condensing

**Physical**

Dimensions: PCIe card

- Depth: 201.6 mm (7.948 in)
- Height: 111.25 mm (4.376 in)

FLEXORSET MODELS

This chart shows all available FlexorSets. Click on model numbers for more information.

Form Factor	Software/FPGA Tools	Carrier Model	FMC Model	FlexorSet Model	Description			
3U VPX	Virtex-7 ReadyFlow BSP GateFlow FDK Vivado	5973	3312	5973-312	4-Channel 250 MHz A/D & 2-Channel 800 MHz D/A			
				5973-313	4-Channel 250 MHz A/D & 2-Channel 800 MHz D/A with 4 multiband DDCs & interpolation filters			
			3316	5973-316	8-Channel 250 MHz 16-bit A/D			
				5973-317	8-Channel 250 MHz 16-bit A/D with 8 multiband DDCs			
			3320	5973-320	2-Channel 3 GHz A/D & 2-Channel 2.8 GHz D/A			
			3324	5973-324	4-Channel 500 MHz A/D & 4-Channel 2 GHz D/A			
	KintexUltraScale Navigator BSP Navigator FDK Vivado	5983*	3312	5983-313*	4-Channel 250 MHz A/D & 2-Channel 800 MHz D/A with 4 multiband DDCs & interpolation filters			
				5983-317*	8-Channel 250 MHz 16-bit A/D with 8 multiband DDCs			
			3320	5983-320*	2-Channel 3 GHz A/D & 2-Channel 2.8 GHz D/A			
			3324	5983-324*	4-Channel 500 MHz A/D & 4-Channel 2 GHz D/A			
			PCIe	Virtex-7 ReadyFlow BSP GateFlow FDK Vivado	7070	3312	7070-312	4-Channel 250 MHz A/D & 2-Channel 800 MHz D/A
							7070-313	4-Channel 250 MHz A/D & 2-Channel 800 MHz D/A with 4 multiband DDCs & interpolation filters
3316	7070-316	8-Channel 250 MHz 16-bit A/D						
	7070-317	8-Channel 250 MHz 16-bit A/D with 8 multiband DDCs						
3320	7070-320	2-Channel 3 GHz A/D & 2-Channel 2.8 GHz D/A						
3324	7070-324	4-Channel 500 MHz A/D & 4-Channel 2 GHz D/A						

\*There is a 5983A version of this product. For differences, see below.

Model 5983	Model 5983A
<p><b>Flash Memory</b> - 1 Gbit of FLASH Memory</p> <p><b>Optical I/O (Option 110) - VITA 66.4</b> - Up to 12 duplex optical lanes are available on a VITA 66.4 connector.</p> <p>With the installation of a serial protocol, the VITA 66.4 interface enables a high-bandwidth connection between 5983s mounted in the same chassis or over extended distances.</p>	<p><b>Flash Memory</b> -2 Gbit of BPI FLASH Memory</p> <p><b>Optical I/O (Option 110) - VITA 67.3D</b> - Provides 12 duplex lanes @ 10 Gb/sec through the lower half of VPX P2 (VPX P2B).</p> <p>With the installation of a serial protocol, the VITA 67.3D interface enables gigabit communications between boards and chassis, independent of the PCIe interface.</p>
	<p><b>Custom Analog I/O (Option 113) - VITA 67.3</b> - VITA 67.3 provides 10 coax connections through the lower half of VPX P2.</p>

ORDERING INFORMATION

Model	Description
7070-320	2-Channel 3.0 GHz A/D, 2-Channel 2.8 GHz D/A with Virtex-7 FPGA - x8 PCIe

Options:

-076	XC7VX690T-2 FPGA
-110	12x gigabit serial optical I/O with XC7VX690T FPGA, 4X with XC7VX330T
-702	Air-cooled, Level 2
-763	Conduction-cooled, Level 3

Contact Mercury for compatible option combinations and complete specifications of rugged and conduction-cooled versions. Options may change, so be sure to contact Mercury for the latest information.

ACCESSORY PRODUCTS

Model	Description
2171	Cable Kit: SSMC to SMA
7892	High-Speed Synchronizer and Distribution Board - PCIe Model
9192	Rackmount High-Speed System Synchronizer Unit Model

DEVELOPMENT SYSTEMS

Mercury offers development systems for Flexor products. They come with all pre-tested software and hardware ready for immediate operation. These systems are intended to save engineers and system integrators the time and expense associated with building and testing a development system that ensures optimum performance of Flexor boards. Please contact Mercury to configure a system that matches your requirements.

LIFETIME SUPPORT FOR FLEXOR PRODUCTS

Mercury offers worldwide customers shorter development time, reliable, rugged solutions for a variety of environments, reduced costs, and mature software development tools. We offer free lifetime support from our engineering staff, which customers can depend on through phone and email, as well as software updates. Take advantage of our 40 years of experience in delivering high-performance radar, communications, SIGINT, EW, and data acquisition MIL-Aero solutions worldwide.



Corporate Headquarters

50 Minuteman Road  
Andover, MA 01810 USA  
**+1 978.967.1401** tel  
**+1 866.627.6951** tel  
**+1 978.256.3599** fax

International Headquarters

**Mercury International**  
Avenue Eugène-Lance, 38  
PO Box 584  
CH-1212 Grand-Lancy 1  
Geneva, Switzerland  
**+41 22 884 5100** tel

Learn more

Visit: [mrcy.com/go/MP7070-320](http://mrcy.com/go/MP7070-320)

For technical details, contact:  
[mrcy.com/CF7070-320](http://mrcy.com/CF7070-320)



The Mercury Systems logo and the following are trademarks or registered trademarks of Mercury Systems, Inc.: Mercury Systems, Innovation That Matters, Cobalt, Flexor, FlexorSet, GateFlow, ReadyFlow, Onyx, and Navigator. Other marks used herein may be trademarks or registered trademarks of their respective holders. Mercury believes this information is accurate as of its publication date and is not responsible for any inadvertent errors. The information contained herein is subject to change without notice.

