

AM3269 – Signal Conditioning Module

2 to 18 GHz Preselector

AM3269 is a configurable RF signal conditioning preselector module covering the 2 GHz to 18 GHz frequency range with 4 RX and 4 TX channels. Each channel provides independently adjustable filters and gain control for dynamic signal environments. Its small size, weight and power consumption make it an attractive choice for demanding applications requiring low SWaP.

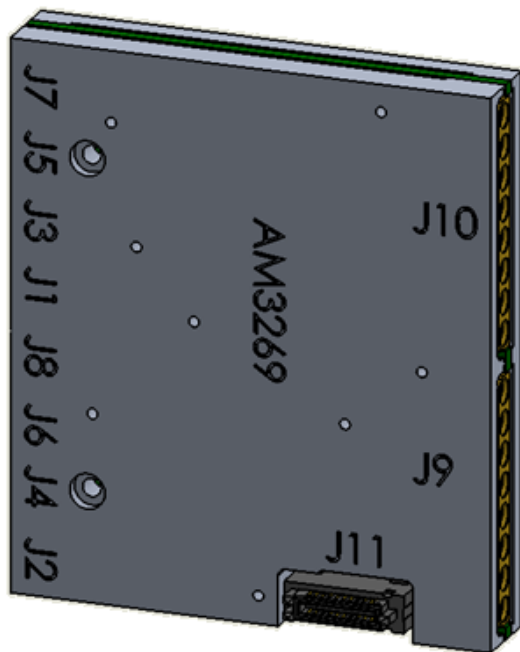

Features

- 2 to 18 GHz RF Signal Conditioner
- 4 RX and 4 TX Channels
- Internal TX to RX Loopback
- 30 dB of Gain Control
- 30 dB Gain Typical (RX and TX)
- 10 dB Noise Figure Typical (RX and TX)
- -3 dBm Input IP3 (RX), +30 dBm Output IP3 (TX) Typical
- Internally Stored Gain Calibration for Each Channel
- -40C to +85C Operation

CONTENTS

Features 1

Revision History 3

Functional Diagrams 4

Digital Diagrams 5

Connector Details 6

Connector Details 6

Power and I/O Pin Layout and Definitions 7

Power and I/O Pin Layout and Definitions (Continued) 8

Power and I/O Pin Layout and Definitions (Continued) 9

Specifications 10

Specifications (Continued) 11

Specifications (Continued) 12

Specifications (Continued) 13

RX Path Typical Performance 14

TX Path Typical Performance 15

Typical Bypass Performance 16

Typical P1dB Performance (Single Ended) 17

RX Gain Versus Temperature Bands 1 through 6 (Single Ended) 18

RX Gain Versus Temperature Bands 7 through 12 (Single Ended) 19

RX NF Versus Temperature Bands 1 through 6 (Single Ended) 20

RX NF Versus Temperature Bands 7 through 12 (Single Ended) 21

RX IIP3 Versus Temperature Bands 1 through 6 (Single Ended) 22

RX IIP3 Versus Temperature Bands 7 through 12 (Single Ended) 23

TX Gain Versus Temperature Bands 1 through 6 (Single Ended) 24

TX Gain Versus Temperature Bands 7 through 12 (Single Ended) 25

TX NF Versus Temperature Bands 1 through 6 (Single Ended) 26

TX NF Versus Temperature Bands 7 through 12 (Single Ended) 27

TX OIP3 Versus Temperature Bands 7 through 12 (Single Ended) 29

Typical Bypass Performance 30

Component Compliance Information **Error! Bookmark not defined.**

Revision History

Date	Revision	Notes
5/20/2025	1	Initial release
5/7/2025	2	Updated page 1 Image, updated Block Diagram on page 3 to add frequency range of bypass path, added mounting hole dimensions on page 5, removed junction temperature from max ratings, clarified RF performance as single ended on pages 9 thru 27.
12/8/2025	2.1	Updated datasheet to Mercury format

Functional Diagrams

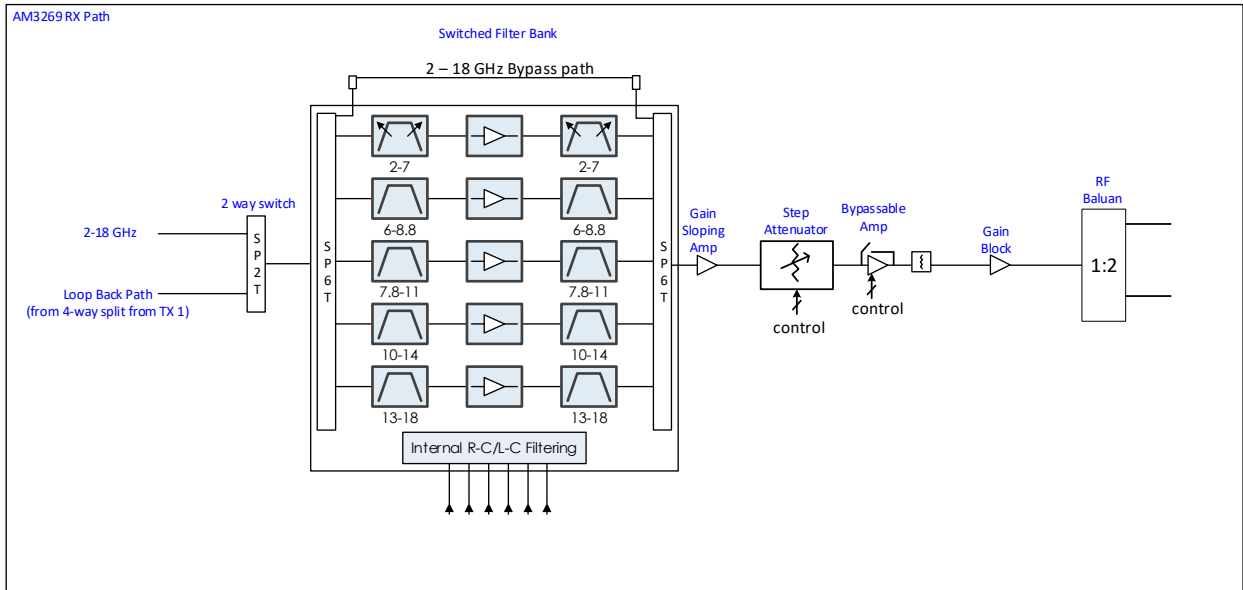
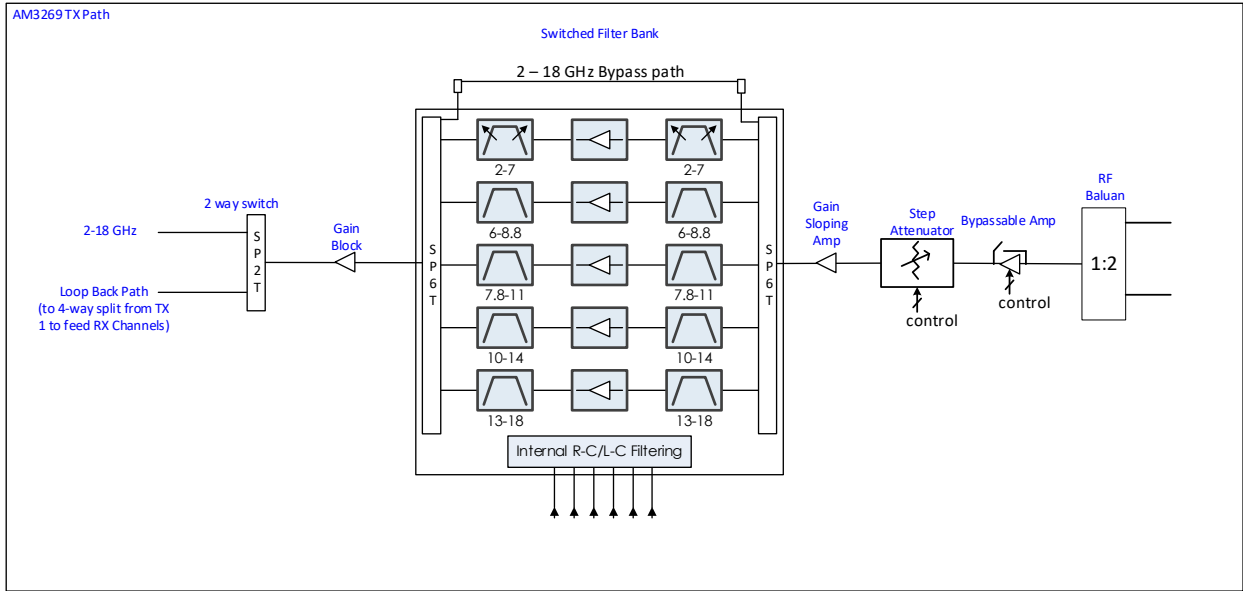

Digital Diagrams

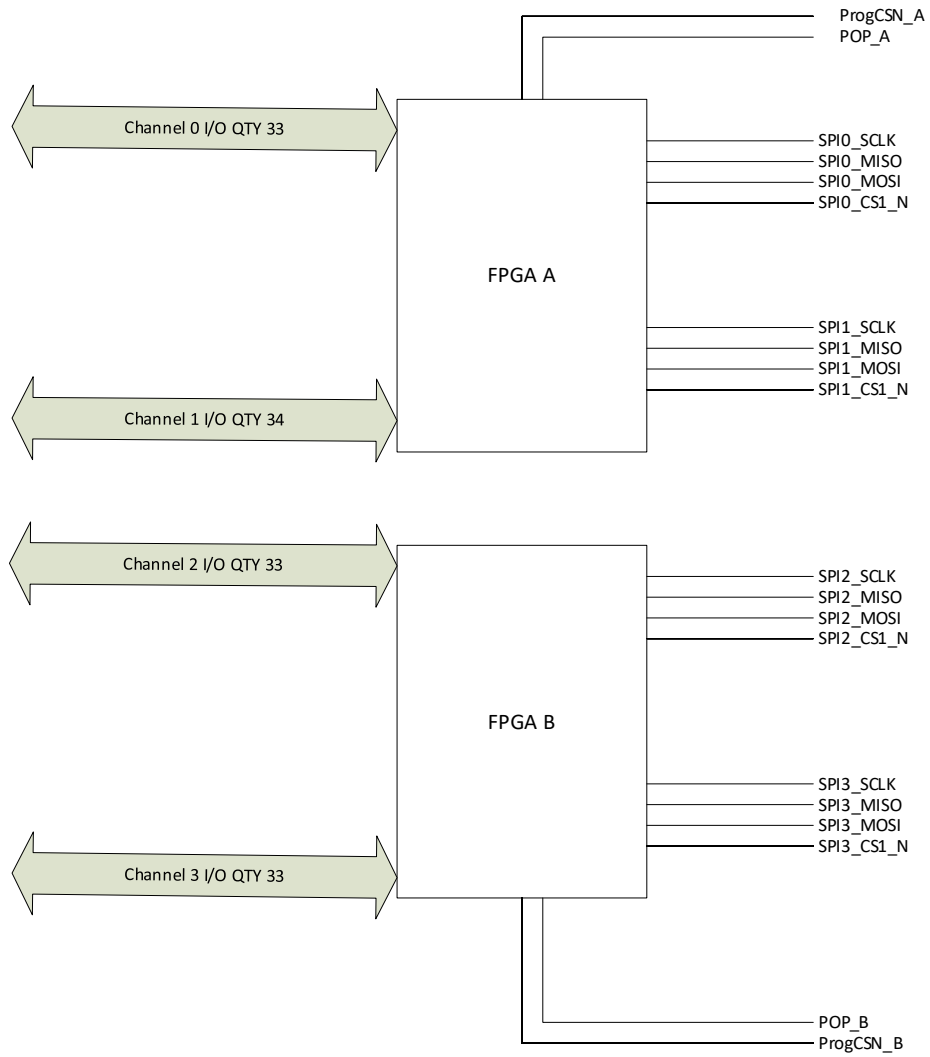

Connector Details

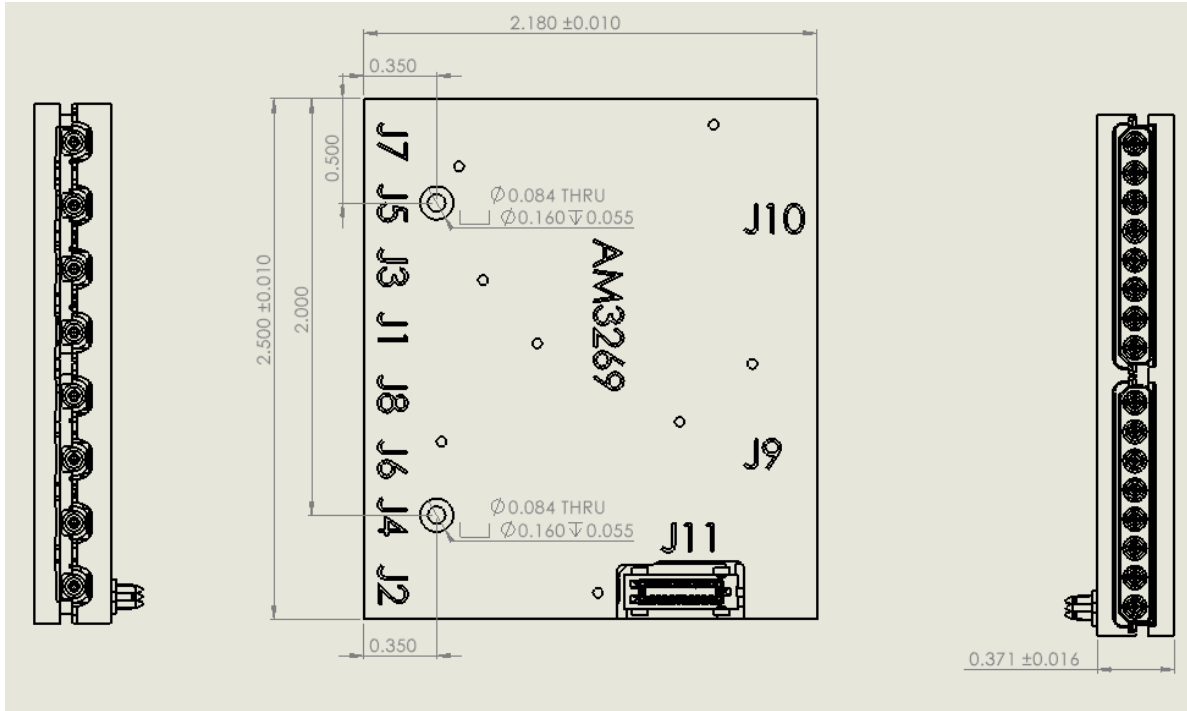

Connector Details

Pin	Description	Function
J1	2GHz to 18GHz TX1 Out	RF Output - 50 Ohms - DC Blocked - SMPM Plug, Full Detent - Molex 0733000020
J2	2GHz to 18GHz TX3 Out	RF Output - 50 Ohms - DC Blocked - SMPM Plug, Full Detent - Molex 0733000020
J3	2GHz to 18GHz RX1 In	RF input - 50 Ohms - DC Blocked - SMPM Plug, Full Detent - Molex 0733000020
J4	2GHz to 18GHz RX3 In	RF input - 50 Ohms - DC Blocked - SMPM Plug, Full Detent - Molex 0733000020
J5	2GHz to 18GHz TX0 Out	RF Output - 50 Ohms - DC Blocked - SMPM Plug, Full Detent - Molex 0733000020
J6	2GHz to 18GHz TX2 Out	RF Output - 50 Ohms - DC Blocked - SMPM Plug, Full Detent - Molex 0733000020
J7	2GHz to 18GHz RX0 In	RF input - 50 Ohms - DC Blocked - SMPM Plug, Full Detent - Molex 0733000020
J8	2GHz to 18GHz RX2 In	RF input - 50 Ohms - DC Blocked - SMPM Plug, Full Detent - Molex 0733000020
J9	2GHz to 18GHz RX2 In/Out	DAC2, DAC3, ADC2, ADC3 - 50 Ohms - DC Blocked - Ganged Multi-Port SMPM Block Samtec PN GPPC-PS-1-08-EG-ST-EM-1N
J10	2GHz to 18GHz RX2 In/Out	DAC0, DAC1, ADC0, ADC1 - 50 Ohms - DC Blocked - Ganged Multi-Port SMPM Block Samtec PN GPPC-PS-1-08-EG-ST-EM-1N
J11	Multipin Connector	Power and I/O Connector - SEAM8-10-S05.0-S-04-3 (4 rows of 10 pins, 0.8mm SEARAY Terminal)

Power and I/O Pin Layout and Definitions

PIN	A	B	C	D
1	RF_3P5V	RF_3P5V	RF_5P2V	RF_5P2V
2	RF_3P5V	RF_3P5V	RF_5P2V	RF_5P2V
3	SPI3_SCLK	SPI2_SCLK	SPI1_SCLK	SPI0_SCLK
4	SPI3_MISO	SPI2_MISO	SPI1_MISO	SPI0_MISO
5	SPI3_MOSI	SPI2_MOSI	SPI1_MOSI	SPI0_MOSI
6	SPI3_CSI_N	SPI2_CSI_N	SPI1_CSI_N	SPI0_CSI_N
7	NC	ProgCSN_A	POP_A	NC
8	NC	ProgCSN_B	POP_B	NC
9	GND	GND	NC	NC
10	GND	GND	GND	GND

Power and I/O Pin Layout and Definitions (Continued)

Pin	Name	Function
A01	RF_3P5V	3.5 Volts
A02	RF_3P5V	3.5 Volts
A03	SPI3_SCLK	Clock for SPI Bus 3
A04	SPI3_MISO	Master Input Slave Output Data Line for SPI Bus 3
A05	SPI3_MOSI	Master Output Slave Input Data Line for SPI Bus 3
A06	SPI3_CSI_N	Chip Select for SPI Bus 3
A07	NC	Not Connected
A08	NC	Not Connected
A09	GND	Ground
A10	GND	Ground
B01	RF_3P5V	3.5 Volts
B02	RF_3P5V	3.5 Volts
B03	SPI2_SCLK	Clock for SPI Bus 2/Programming Interface
B04	SPI2_MISO	Master Input Slave Output Data Line for SPI Bus 2/Programming Interface
B05	SPI2_MOSI	Master Output Slave Input Data Line for SPI Bus 2/Programming Interface
B06	SPI2_CSI_N	Chip Select for SPI Bus 2/Programming Interface
B07	ProgCSN_A	Chip Select for FPGA Programming
B08	ProgCSN_B	Chip Select for FPGA Programming
B09	GND	Ground
B10	GND	Ground
C01	RF_5P2V	5.2 Volts
C02	RF_5P2V	5.2 Volts
C03	SPI1_SCLK	Clock for SPI Bus 1
C04	SPI1_MISO	Master Input Slave Output Data Line for SPI Bus 1
C05	SPI1_MOSI	Master Output Slave Input Data Line for SPI Bus 1
C06	SPI1_CSI_N	Chip Select for SPI Bus 1
C07	POP_A	Active Low Reset Line
C08	POP_B	Active Low Reset Line
C09	NC	Not Connected
C10	GND	Ground

Power and I/O Pin Layout and Definitions (Continued)

Pin	Name	Function
D01	RF_5P2V	5.2 Volts
D02	RF_5P2V	5.2 Volts
D03	SPI0_SCLK	Clock for SPI Bus 0/Programming Interface
D04	SPI0_MISO	Master Input Slave Output Data Line for SPI Bus 0/Programming Interface
D05	SPI0_MOSI	Master Output Slave Input Data Line for SPI Bus 0/Programming Interface
D06	SPI0_CS1_N	Chip Select for SPI Bus 0/Programming Interface
D07	NC	Not Connected
D08	NC	Not Connected
D09	NC	Not Connected
D10	GND	Ground

Specifications

Absolute Maximum Ratings

	Minimum	Maximum
3.5 Volt Supply Voltage	-0.3 V	+6.0 V
5.2 Volt Supply Voltage	-0.3 V	+6.0 V
RF Input Power		+20 dBm
Storage Temperature Range	-50 C	+150 C

Note: Any device operation beyond the Absolute Maximum Ratings may result in permanent damage to the device. The values listed in this table are extremes and do not imply functional operation of the device at these or any other conditions beyond what is listed under Recommended Operating Conditions. Any part subjected to conditions outside of what is recommended for an extended amount of time may suffer from reliability concerns.

Handling Information

	Minimum	Maximum
Storage Temperature Range (Recommended)	-50 C	+125 C



Mercury products are electrostatic sensitive. Follow safe handling practices to avoid damage.

Recommended Operating Conditions

	Minimum	Typical	Maximum
3.5 Volt Supply Voltage	+3.5 V	+3.5 V	+3.7 V
5.2 Volt Supply Voltage	+5.2 V	+5.2 V	+5.4 V
Operating Case Temperature	-40 C		+85 C

DC Electrical Characteristics

(Four Channels, Four RX/TX, T = 25 °C unless otherwise specified)

Parameter	Testing Conditions	Min	Typical	Max
+3.5 VDC Supply		+3.5 V	+3.5 V	+3.7 V
+5.2 VDC Supply		+5.2 V	+5.2 V	+5.2 V
+3.5 VDC Supply			1468 mA	
+5.2 VDC Supply			872 mA	
+3.5 VDC Power Dissipated			5138 mW	
+5.2 VDC Power Dissipated			4535 mW	

Specifications (Continued)

RF Performance

(T = 25 °C unless otherwise specified, gain is single ended combining I and Q will result in a 3dB increase in gain)

Parameter	Testing Conditions	Min	Typical	Max
Frequency Range	RX Path 0 dB Attention	2 GHz		18 GHz
Return Loss	In Band Return Loss		10 dB	
Uncalibrated Gain	f = 2 GHz, Band 1		35 dB	
	f = 10 GHz, Band 10		34 dB	
	f = 18 GHz, Band 12		32 dB	
NF	f = 2 GHz, Band 1		9 dB	
	f = 10 GHz, Band 10		7 dB	
	f = 18 GHz, Band 12		8 dB	
Input IP3	f = 2.175 GHz, Band 1		-5 dBm	
	f = 9.25 GHz, Band 10		-5 dBm	
	f = 18 GHz, Band 12		-11 dBm	
Output P1dB	f = 2.175 GHz, Band 1		13 dBm	
	f = 9.25 GHz, Band 10		12 dBm	
	f = 18 GHz, Band 12		10 dBm	

Specifications (Continued)

RF Performance (Continued)

(T = 25 °C unless otherwise specified, gain is single ended combining I and Q will result in a 3dB increase in gain)

Parameter	Testing Conditions	Min	Typical	Max
Frequency Range	TX Path 0 dB Attention	2 GHz		18 GHz
Uncalibrated Gain	f = 2 GHz, Band 1		35 dB	
	f = 10 GHz, Band 10		34 dB	
	f = 18 GHz, Band 12		33 dB	
NF	f = 2 GHz, Band 1		10 dB	
	f = 10 GHz, Band 10		12 dB	
	f = 18 GHz, Band 12		13 dB	
Output IP3	f = 2 GHz, Band 1		32 dBm	
	f = 10 GHz, Band 10		28 dBm	
	f = 18 GHz, Band 12		23 dBm	
Output P1dB	f = 2 GHz, Band 1		20 dBm	
	f = 10 GHz, Band 10		21 dBm	
	f = 18 GHz, Band 12		15 dBm	
Isolation	RX to RX or TX to TX		55 dB	
Isolation	TX to RX		55 dB	
Loopback Gain ⁽¹⁾	TX 1 to RX 1 thru 4		60 dB	

1. It is recommended to maximize both the TX 1 attenuator and the RX attenuators when using the loopback path.

Timing Characteristics

Parameter	Testing Conditions	Min	Typical	Max
Tuning Speed	50% of CSN line to 90%/10% RF		0.7 μs	1.0 μs

Specifications (Continued)

State Table

State	Minimum	Maximum
0	2.0	18
1	2.1	3.0
2	2.2	3.2
3	2.2	3.4
4	2.3	3.7
5	2.5	4.3
6	2.8	4.8
7	3.4	5.5
8	4.4	7.0
9	5.6	8.7
10	7.1	11.5
11	9.8	14.7
12	12.9	19.1

RX Path Typical Performance

(Single Ended Levelled Rx Gain, NF, IIP3)

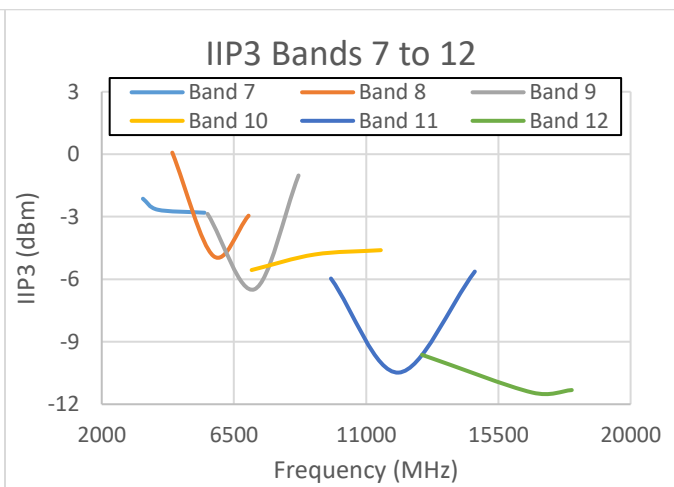
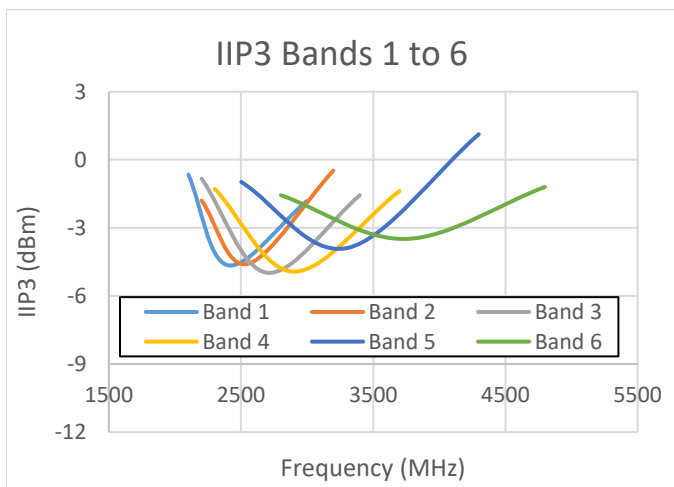
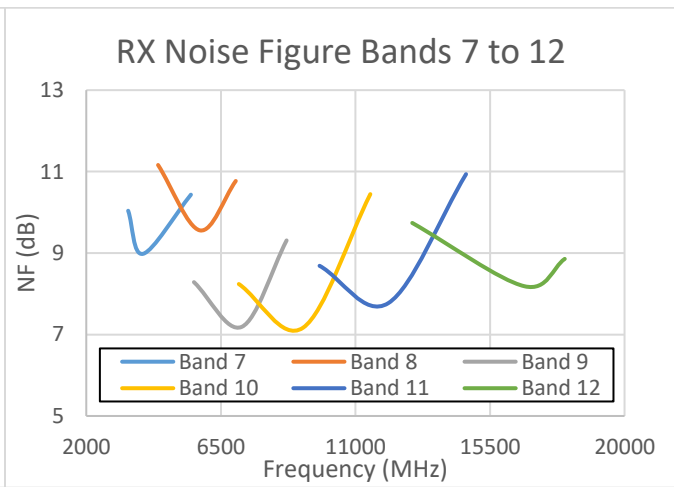
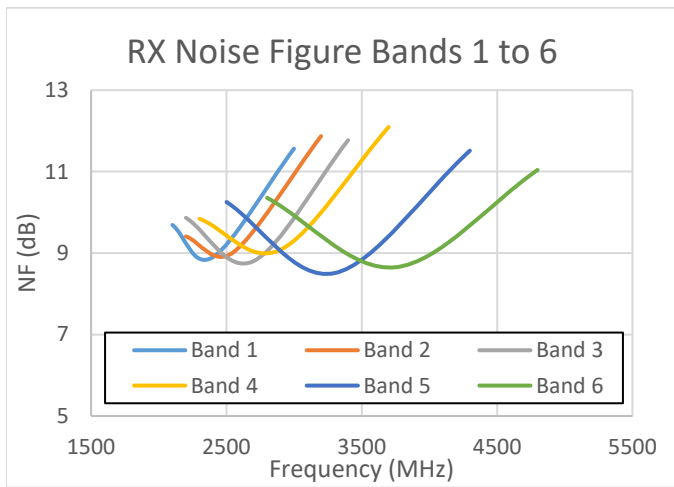
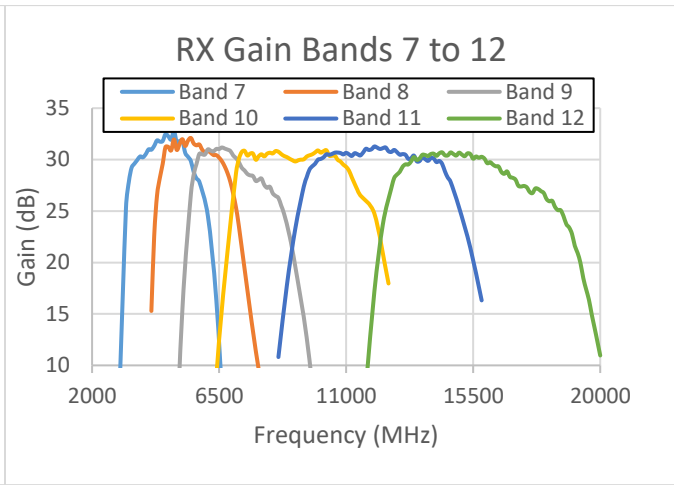
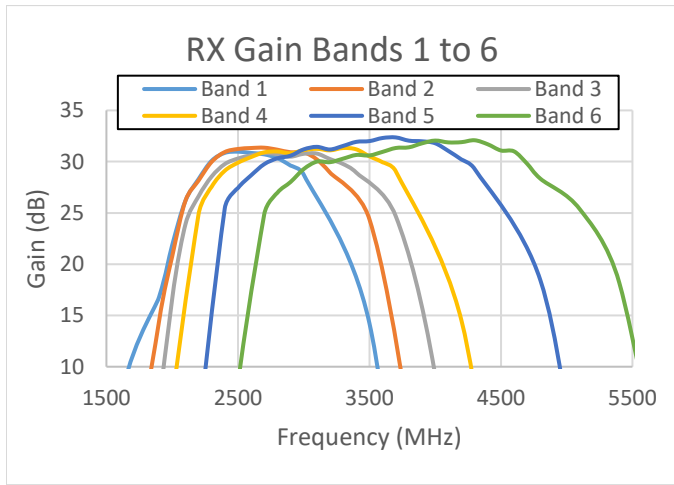

TX Path Typical Performance

(Single Ended Levelled Rx Gain, NF, IIP3)

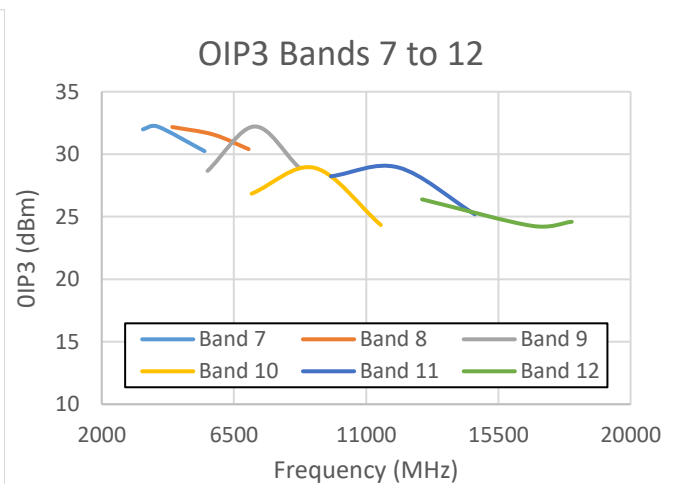
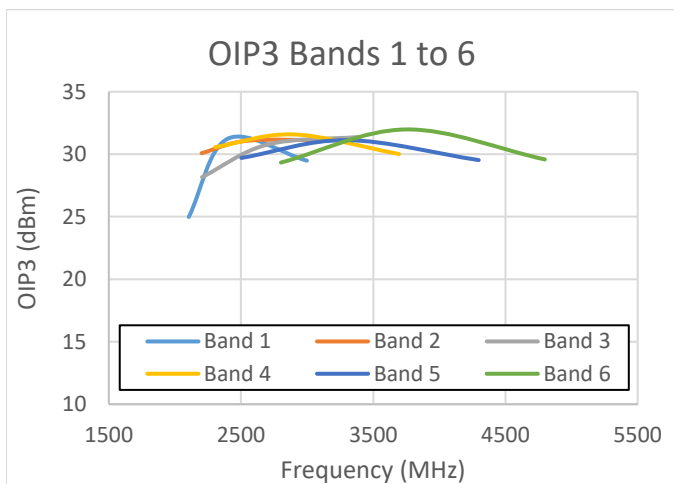
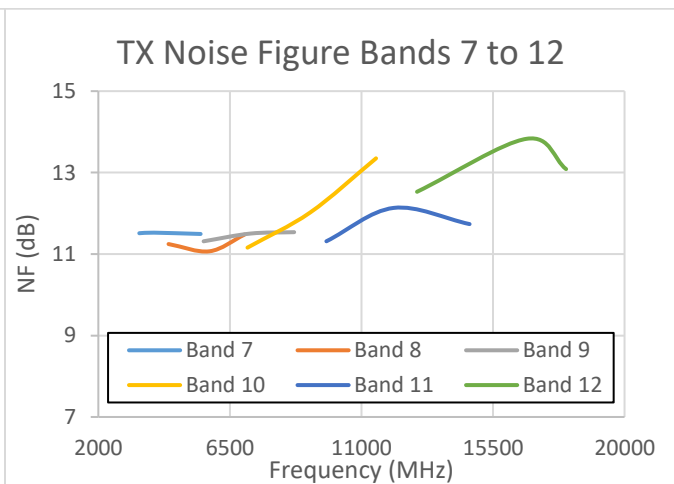
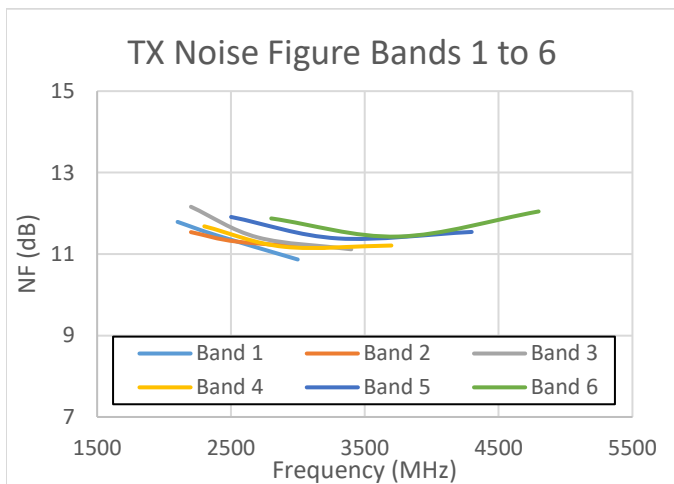
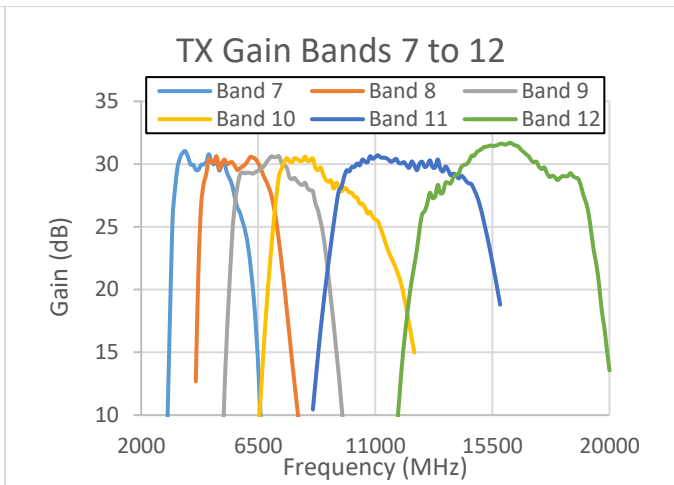
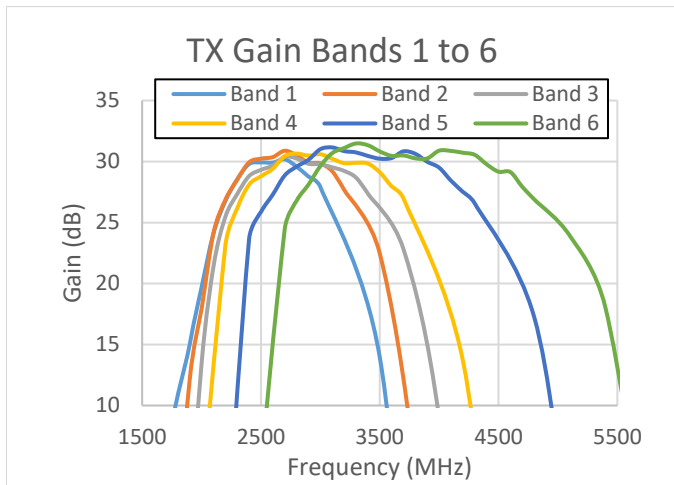

Typical Bypass Performance

(Single Ended Bypass Gain, IP3, NF)

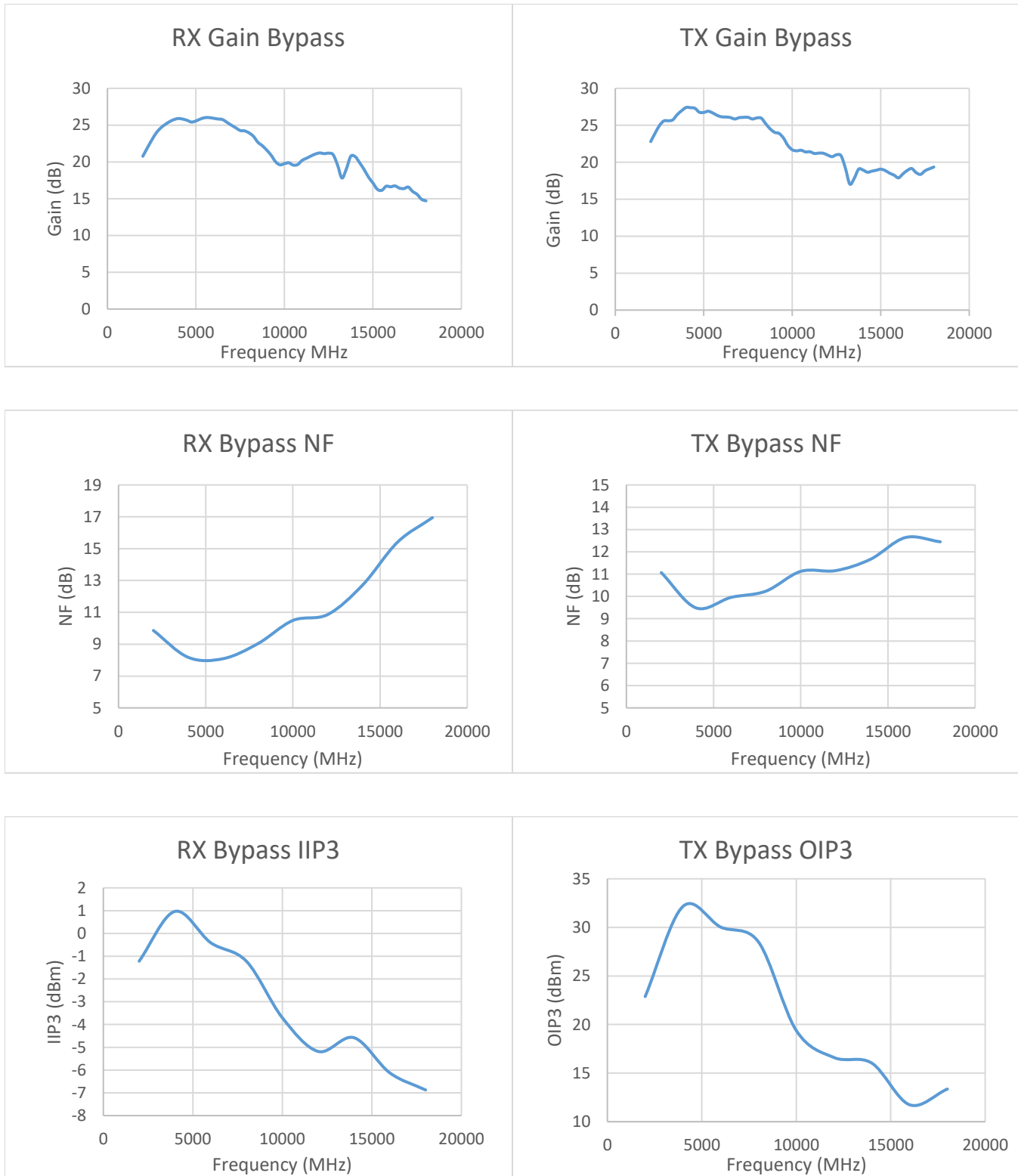

Typical P1dB Performance (Single Ended)

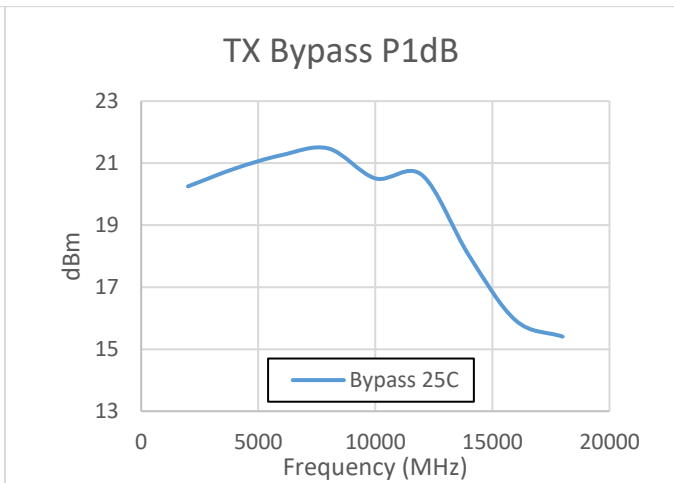
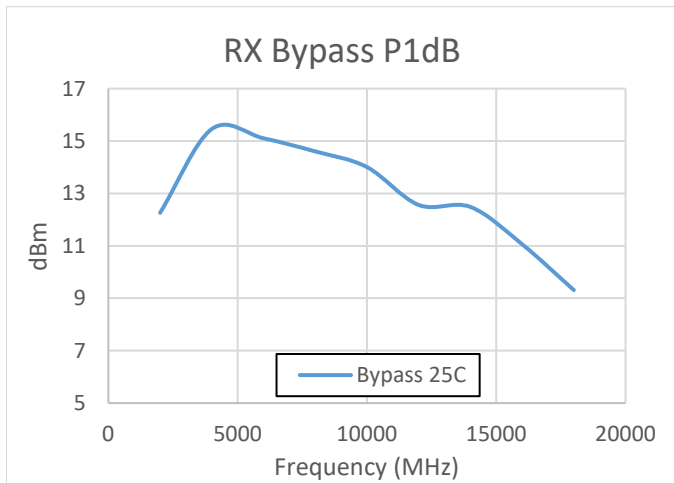
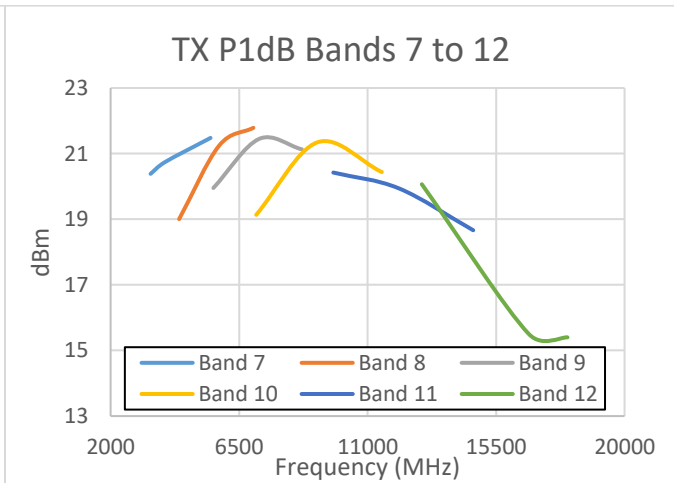
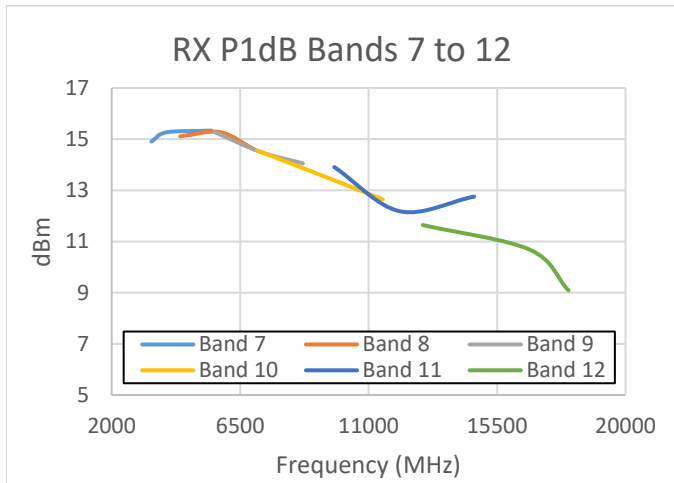
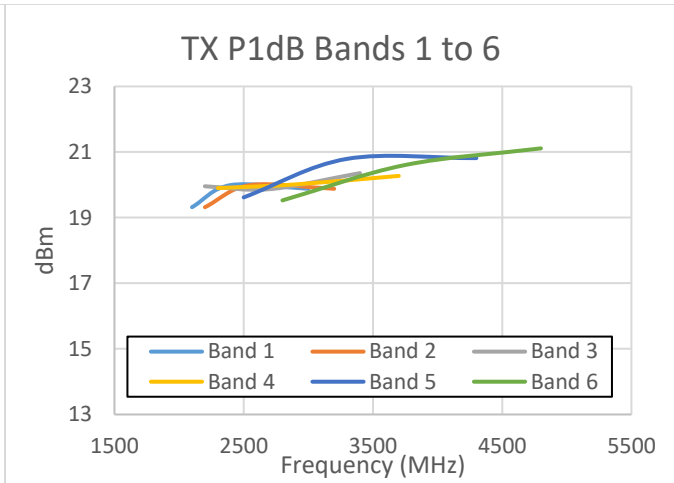
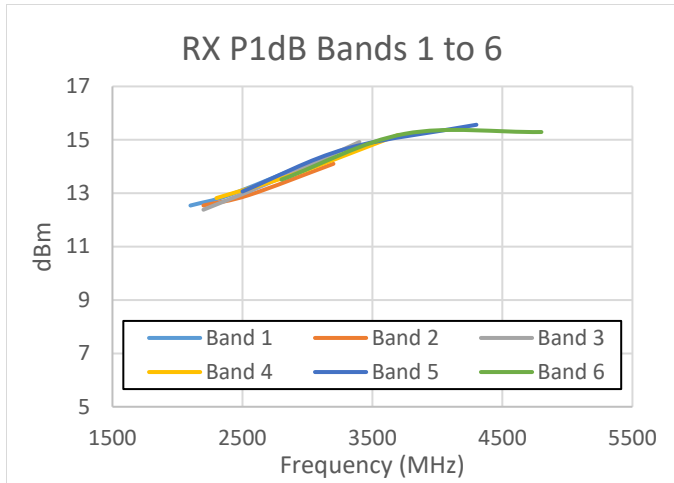

RX Gain Versus Temperature Bands 1 through 6 (Single Ended)

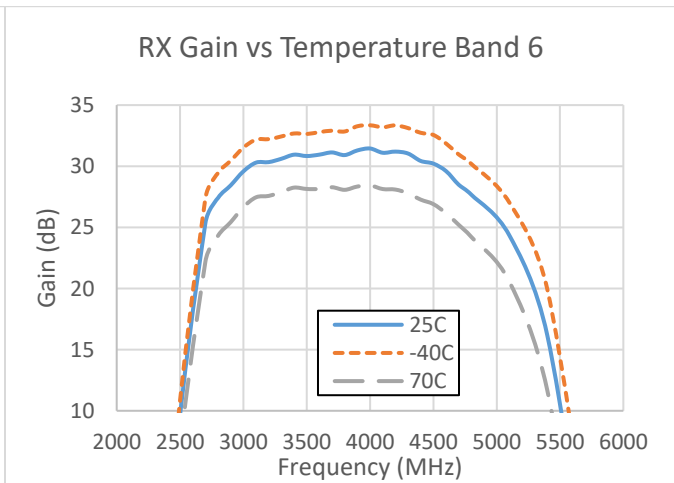
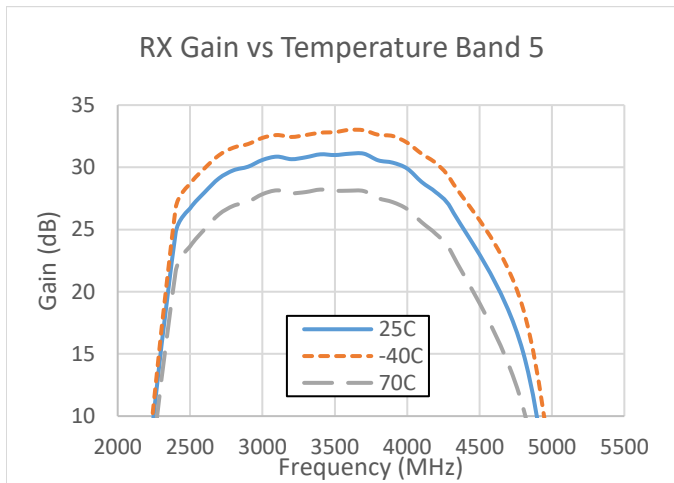
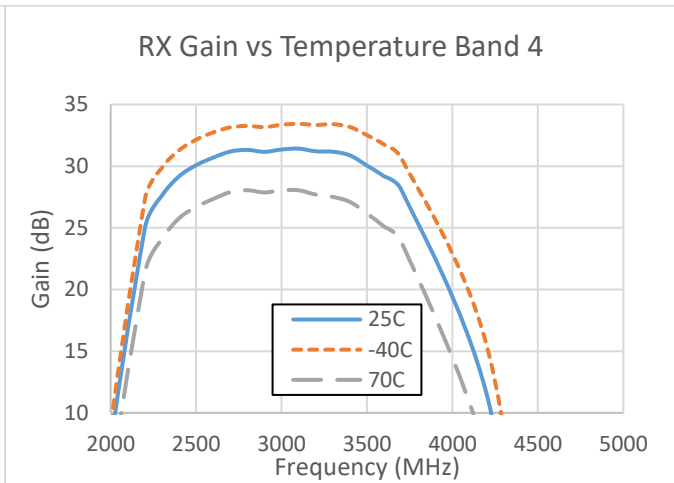
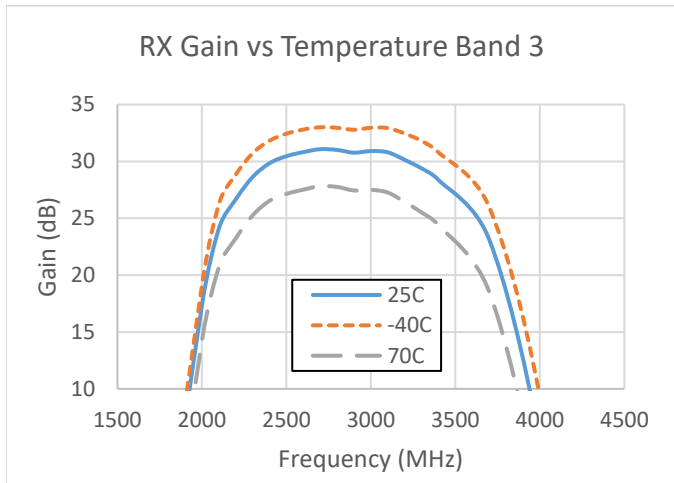
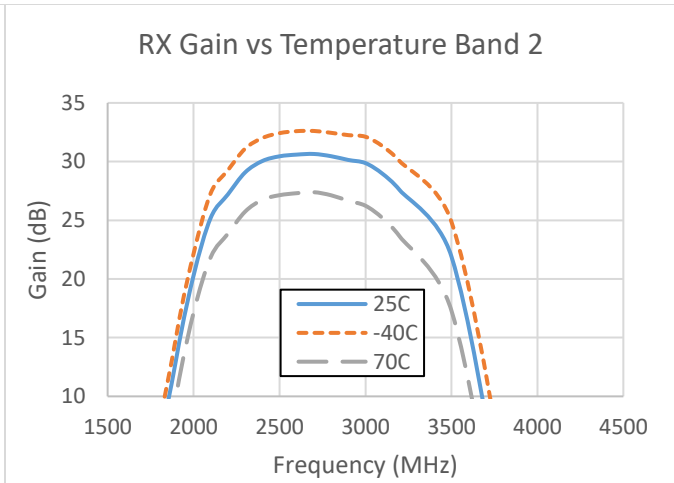
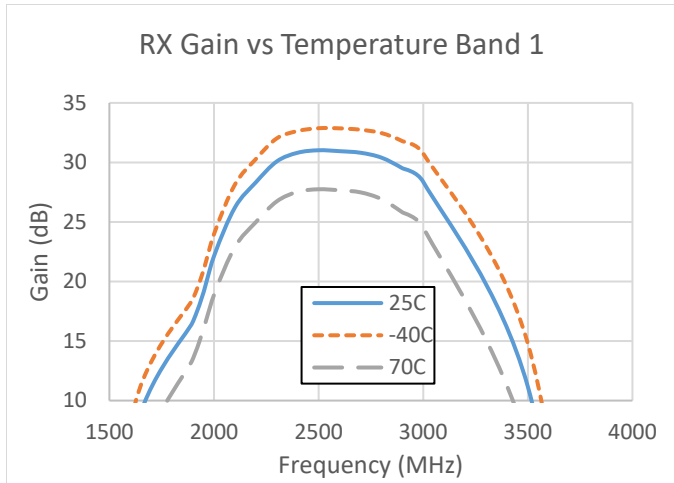

RX Gain Versus Temperature Bands 7 through 12 (Single Ended)

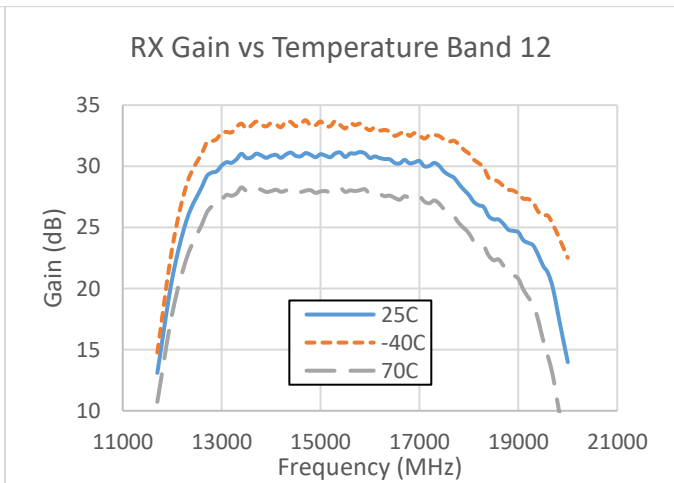
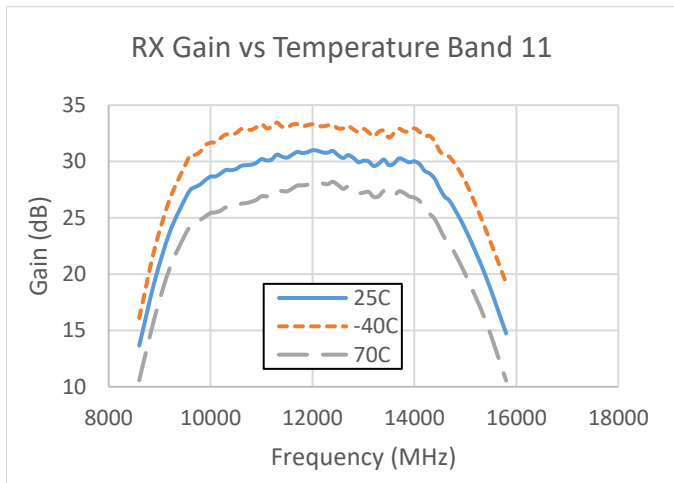
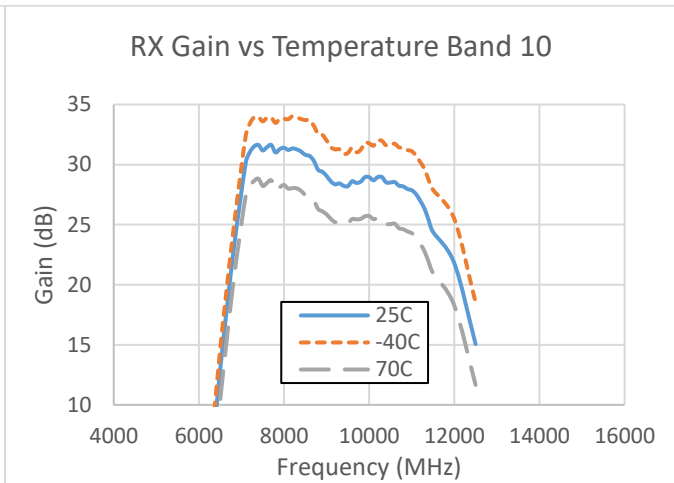
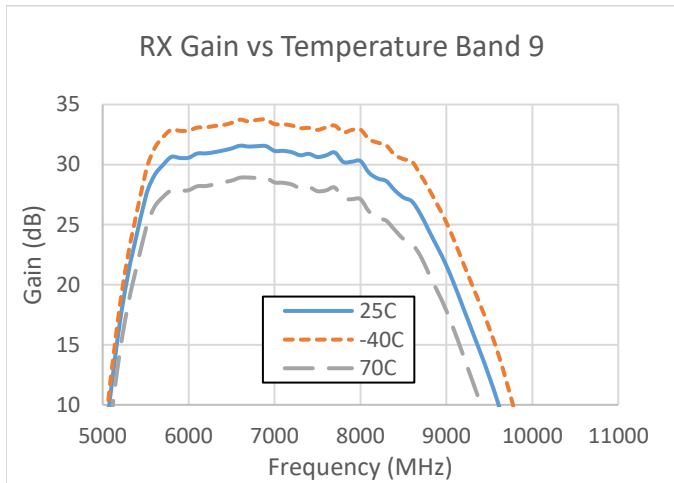
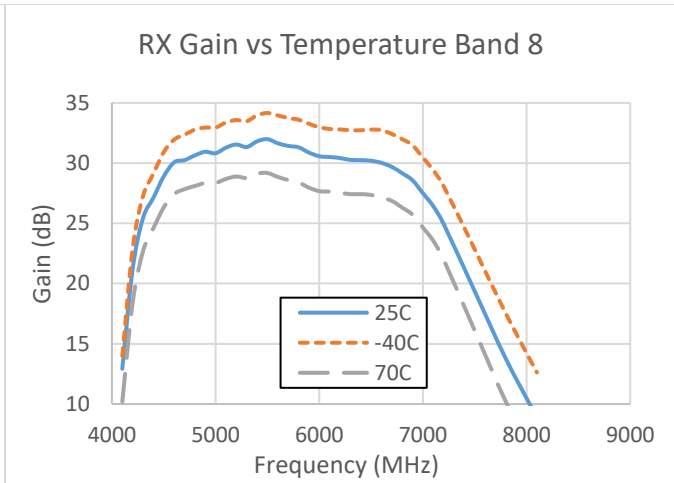
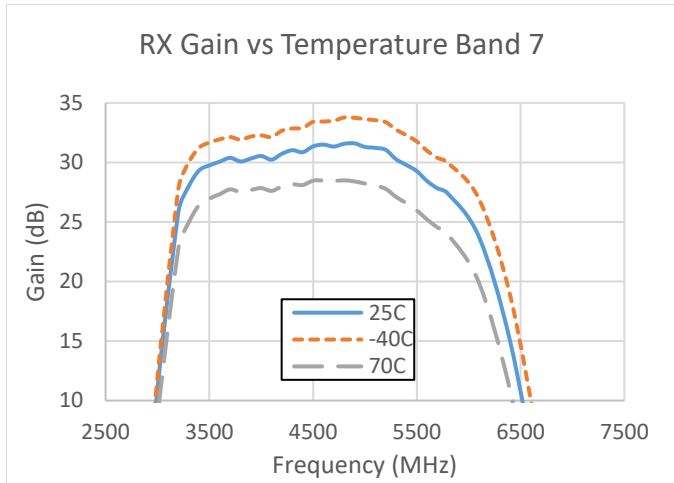

RX NF Versus Temperature Bands 1 through 6 (Single Ended)

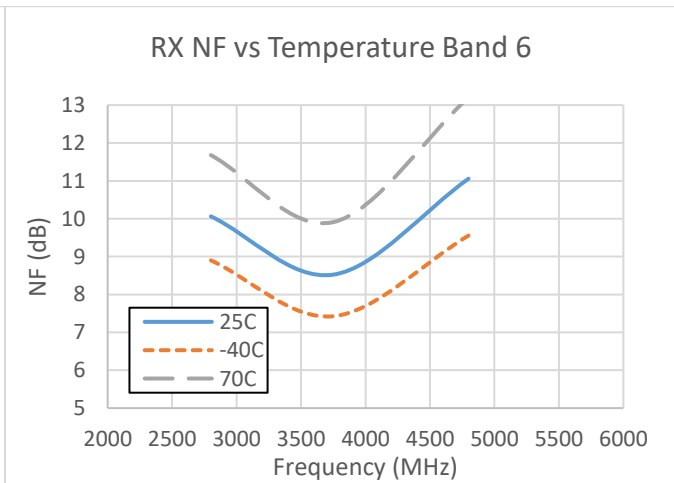
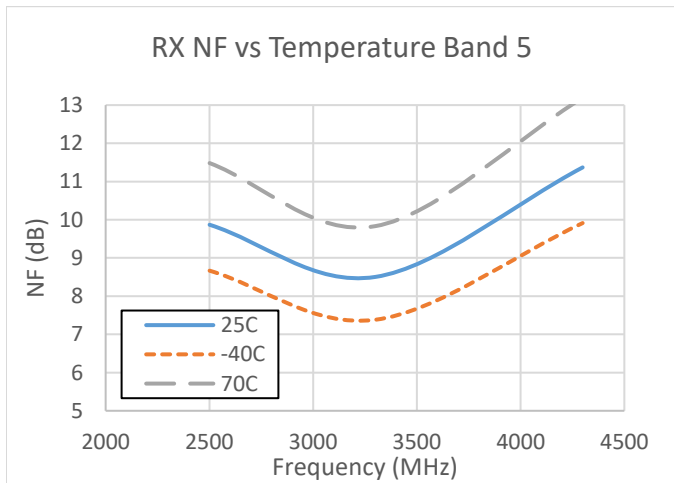
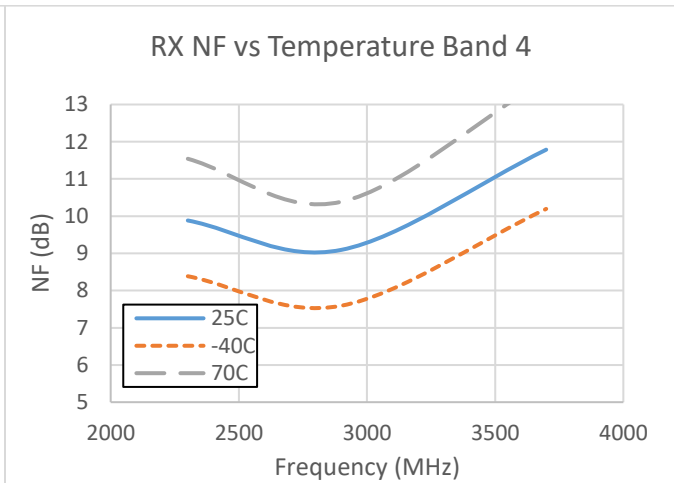
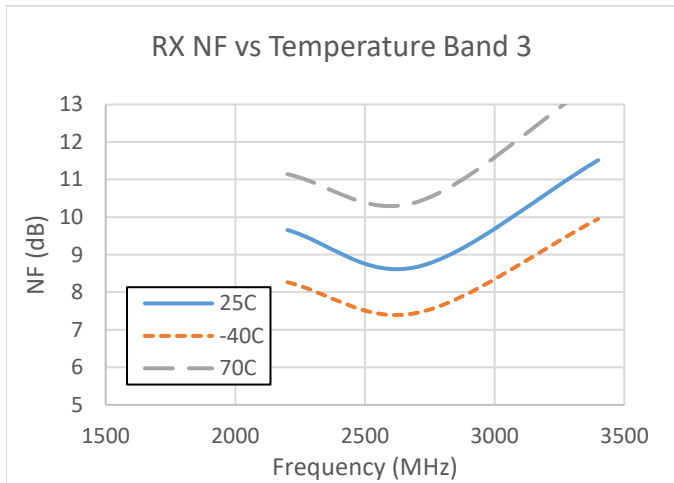
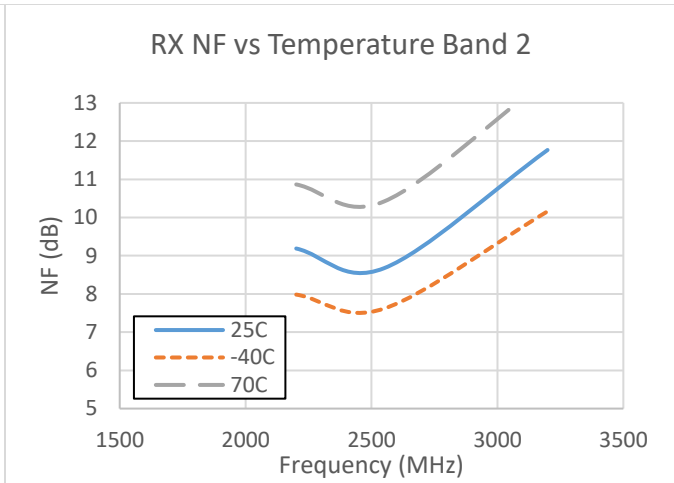
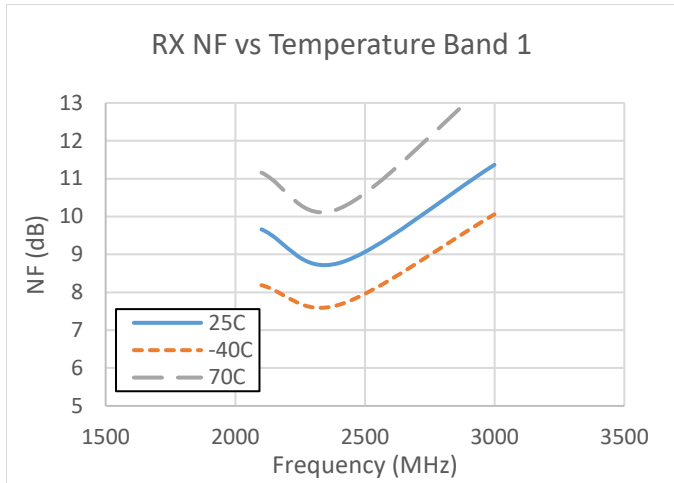

RX NF Versus Temperature Bands 7 through 12 (Single Ended)

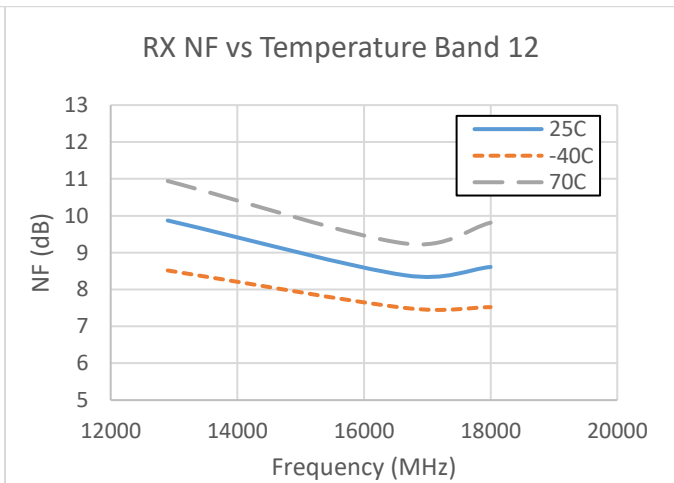
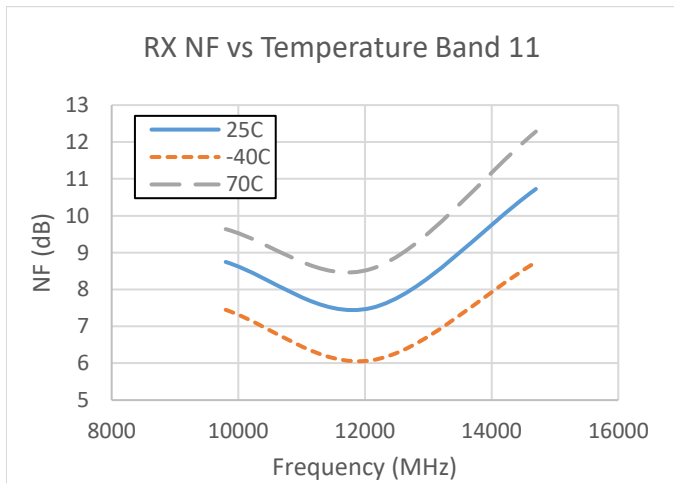
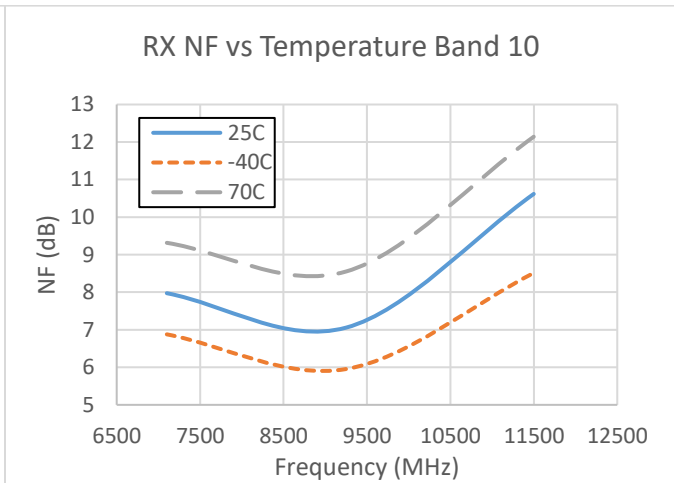
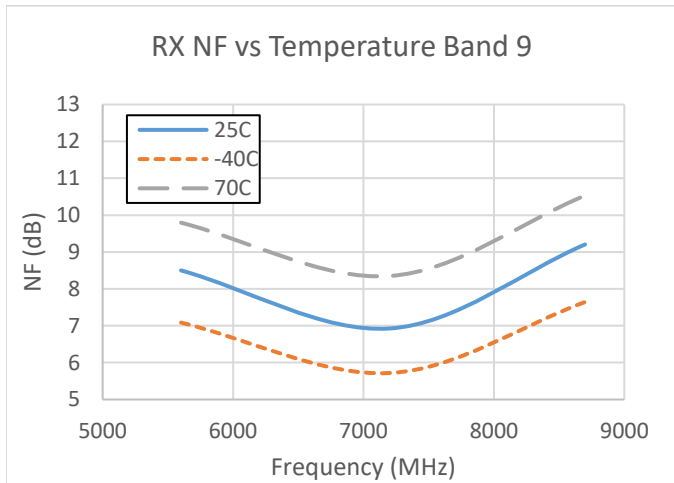
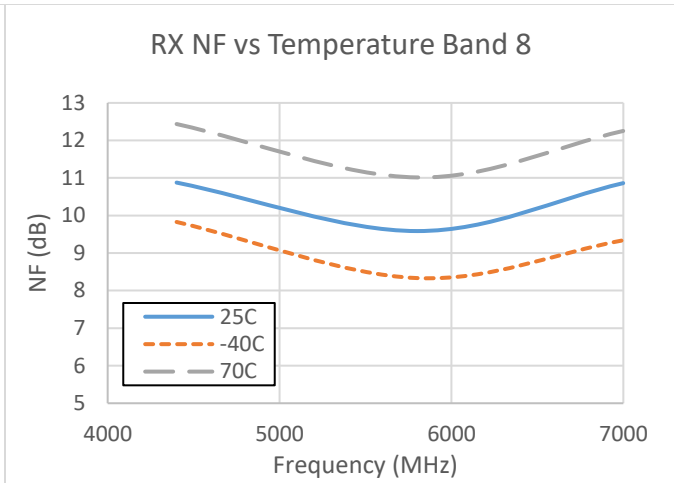
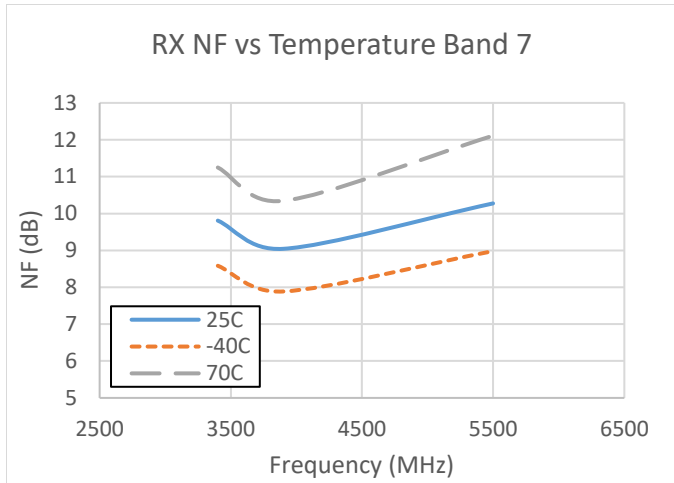

RX IIP3 Versus Temperature Bands 1 through 6 (Single Ended)

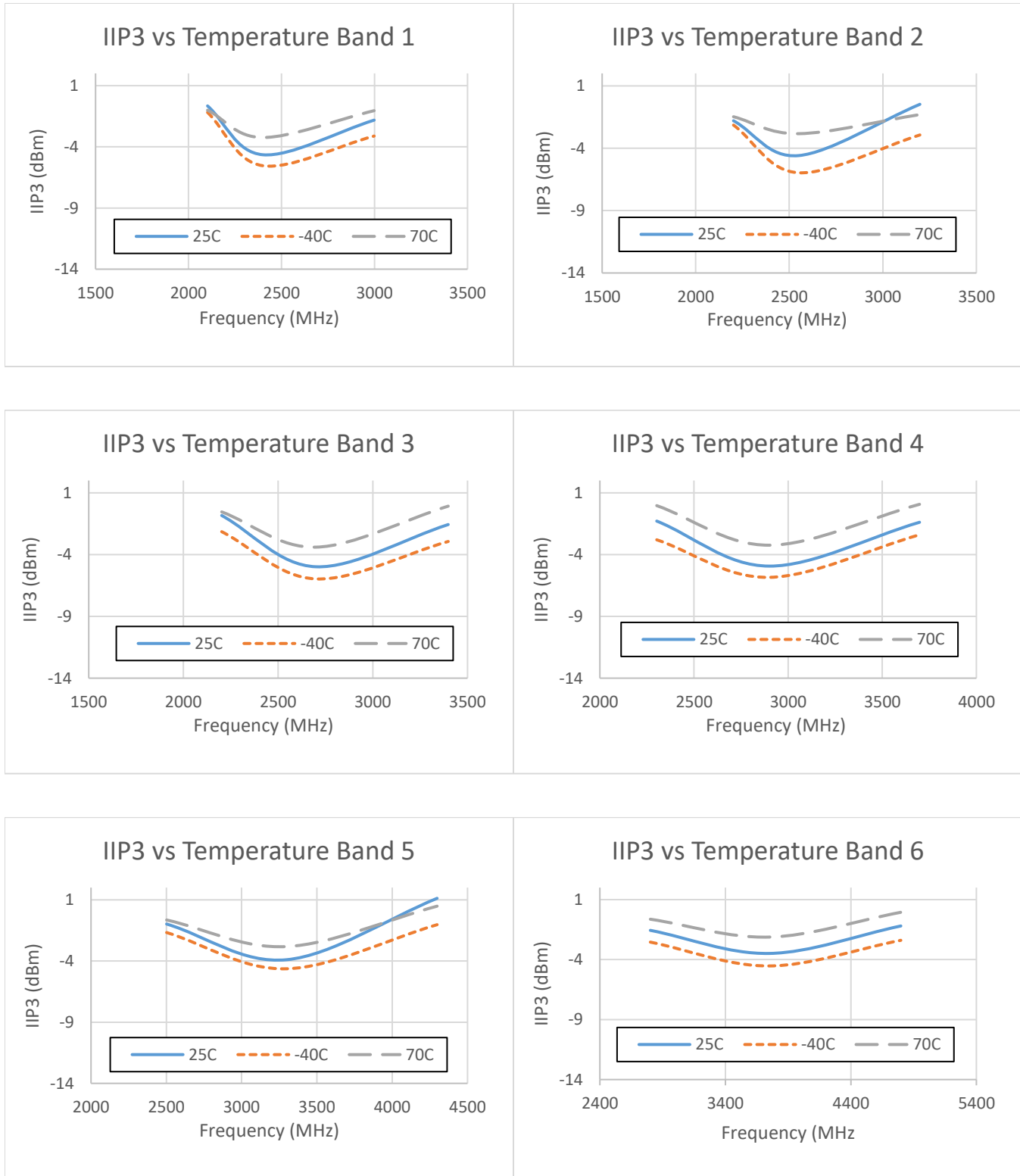

RX IIP3 Versus Temperature Bands 7 through 12 (Single Ended)

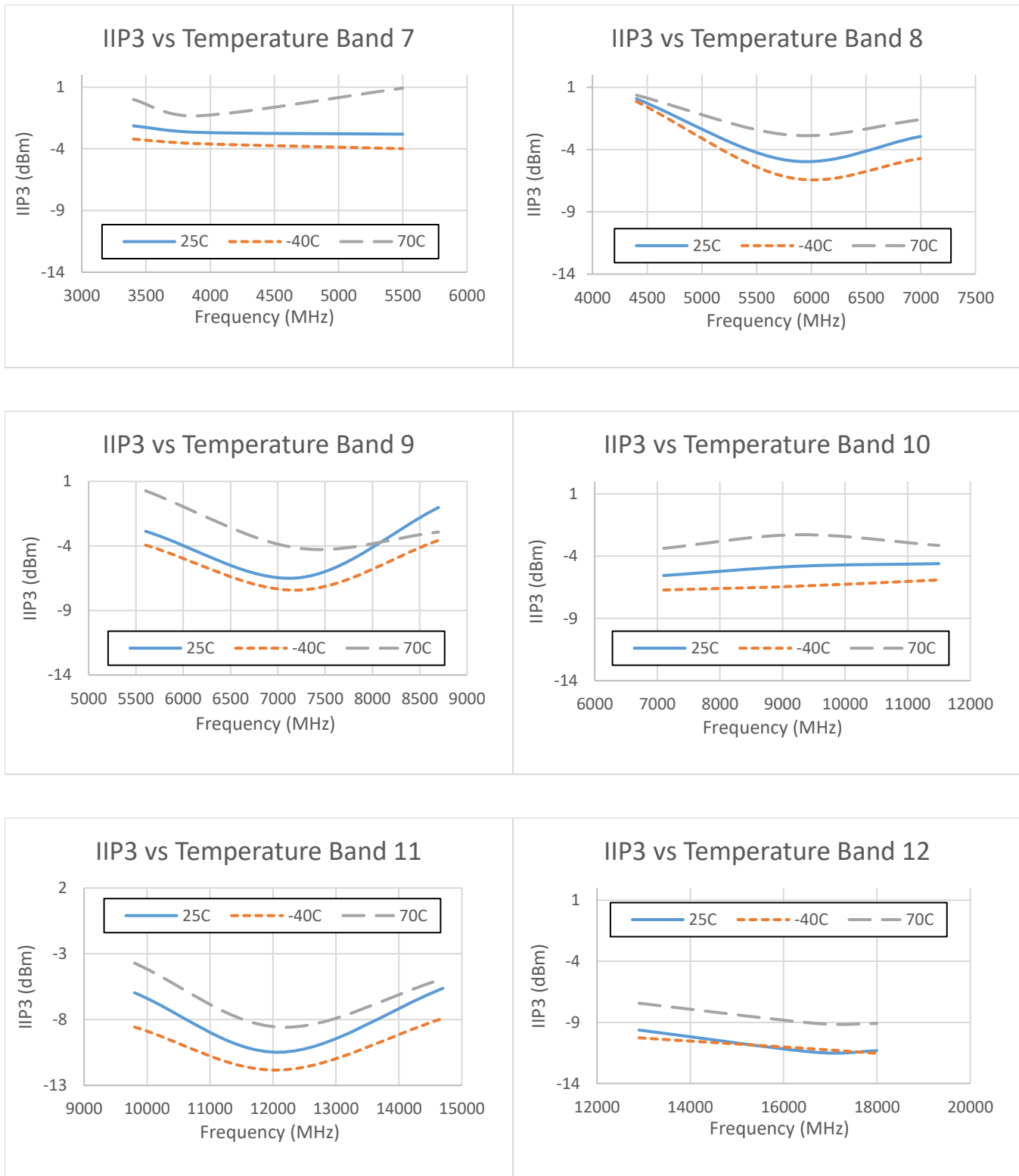

TX Gain Versus Temperature Bands 1 through 6 (Single Ended)

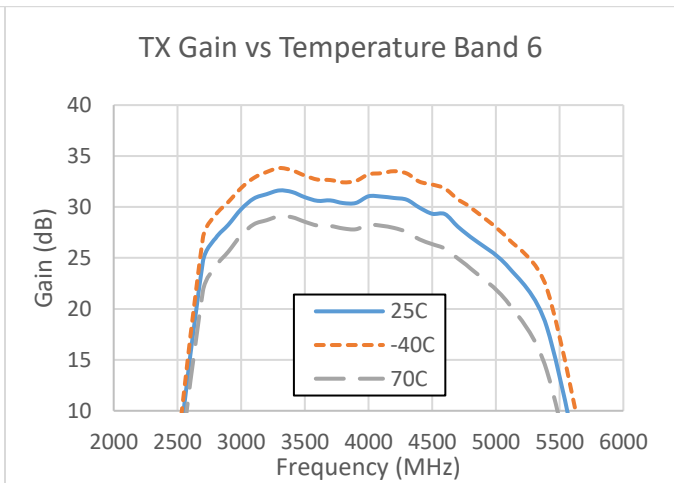
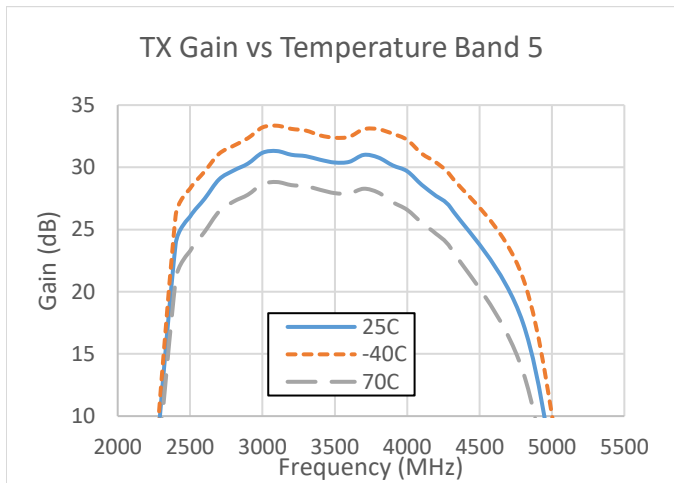
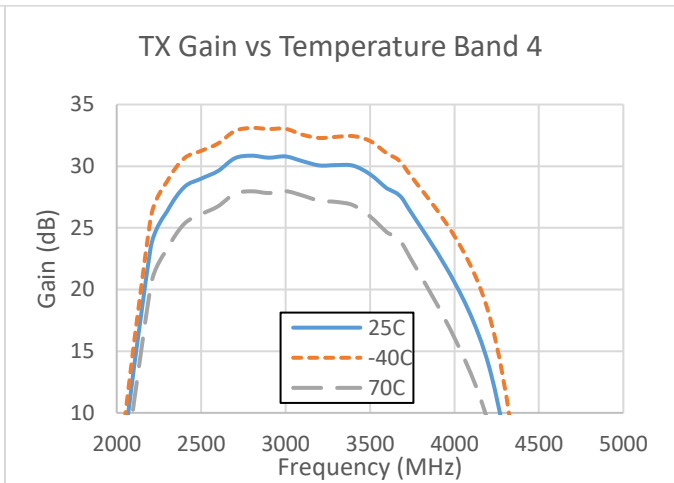
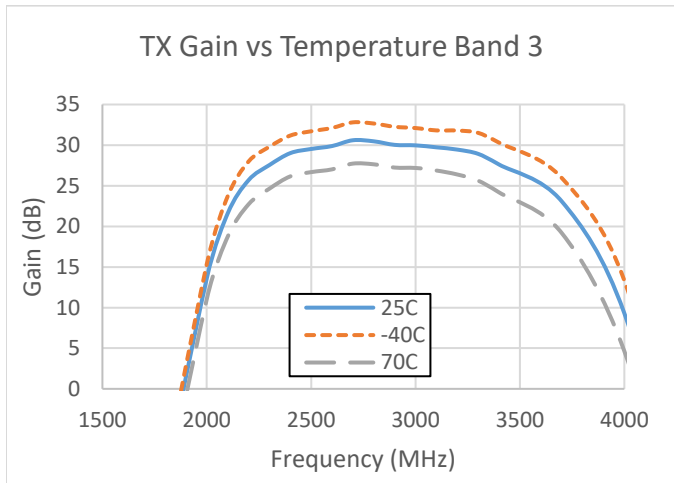
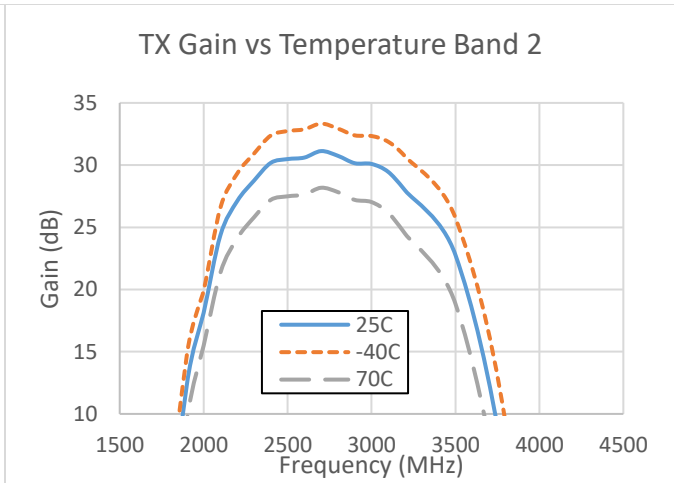
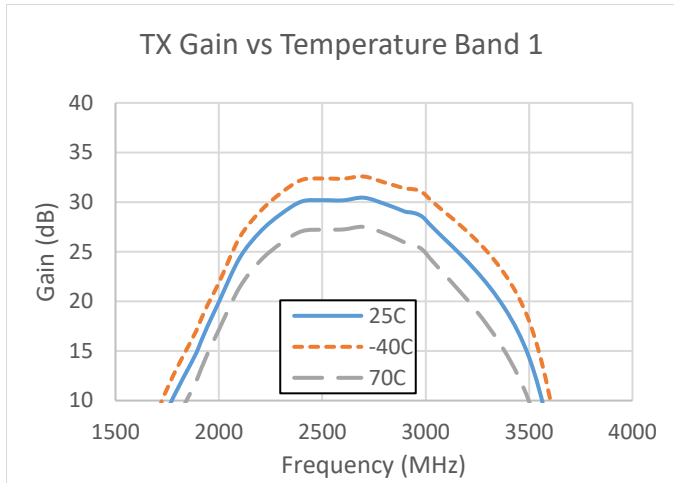

TX Gain Versus Temperature Bands 7 through 12 (Single Ended)

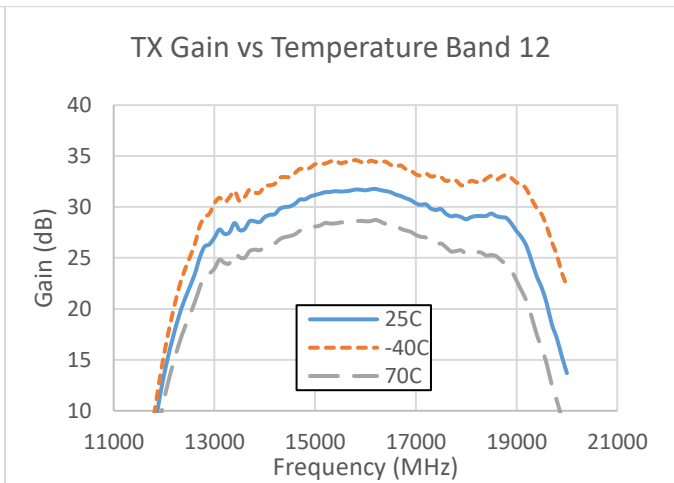
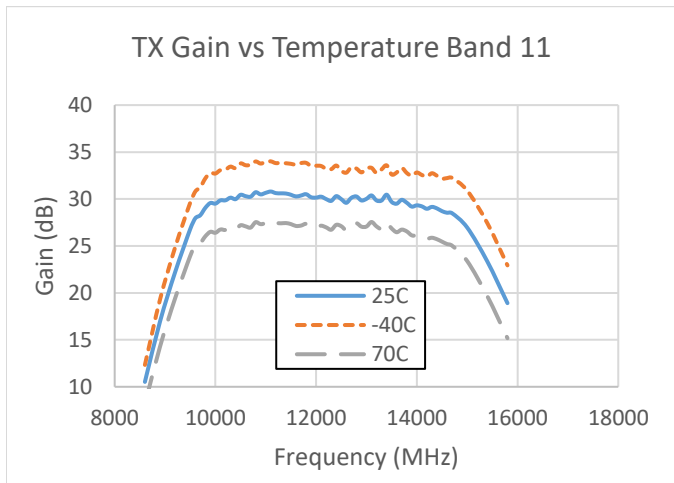
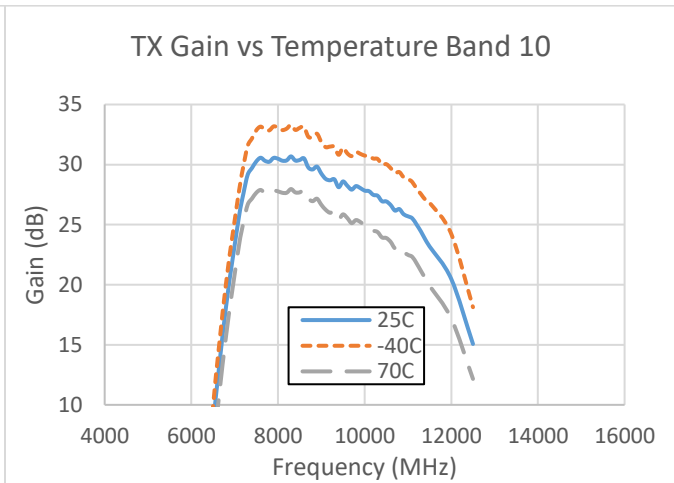
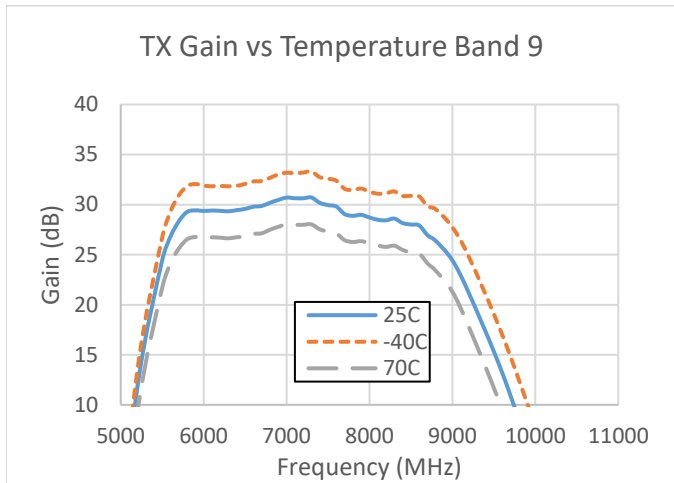
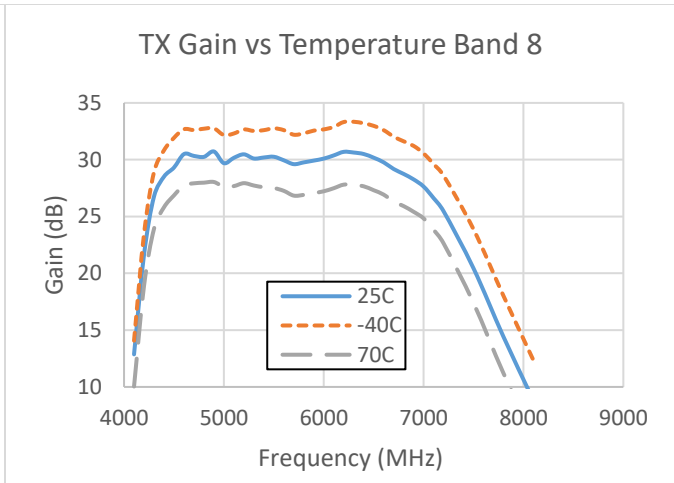
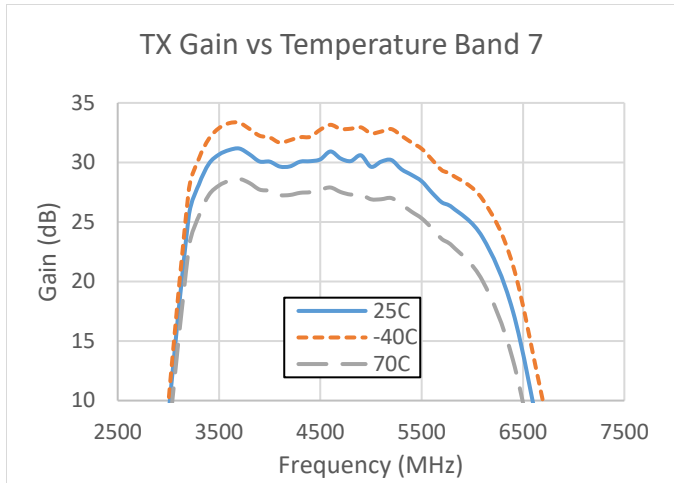

TX NF Versus Temperature Bands 1 through 6 (Single Ended)

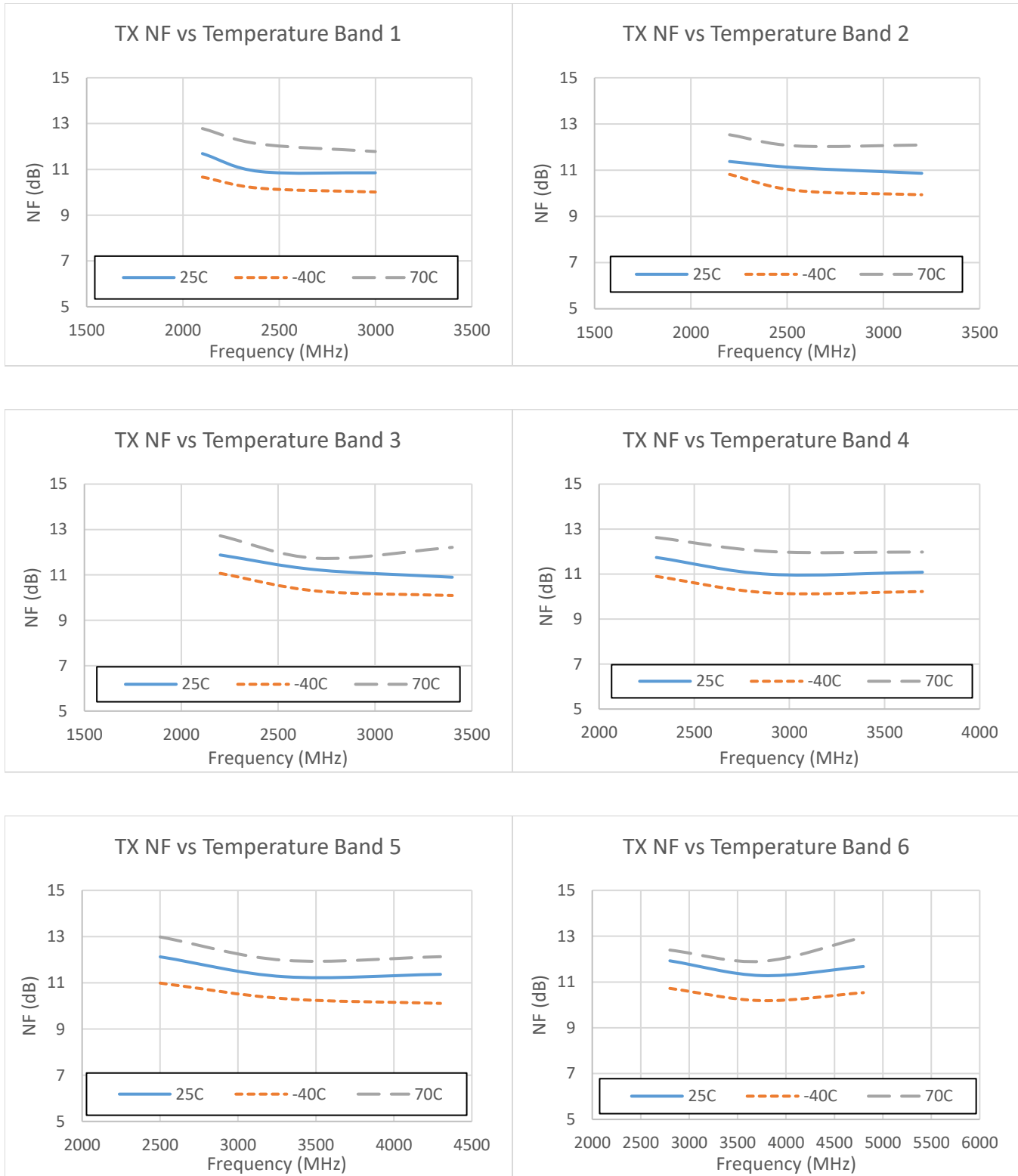

TX NF Versus Temperature Bands 7 through 12 (Single Ended)

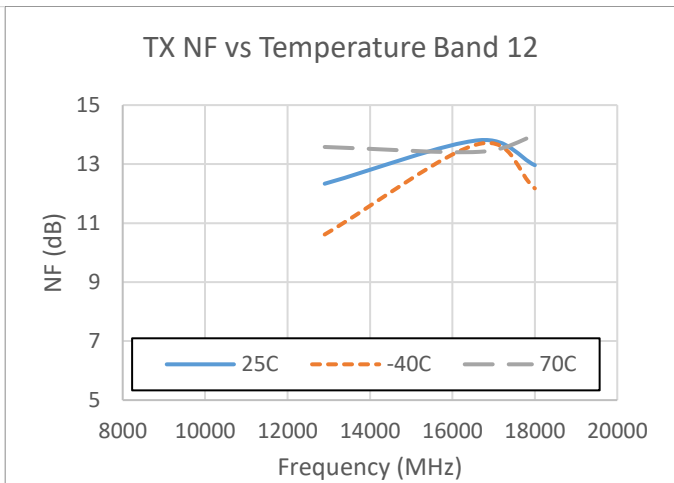
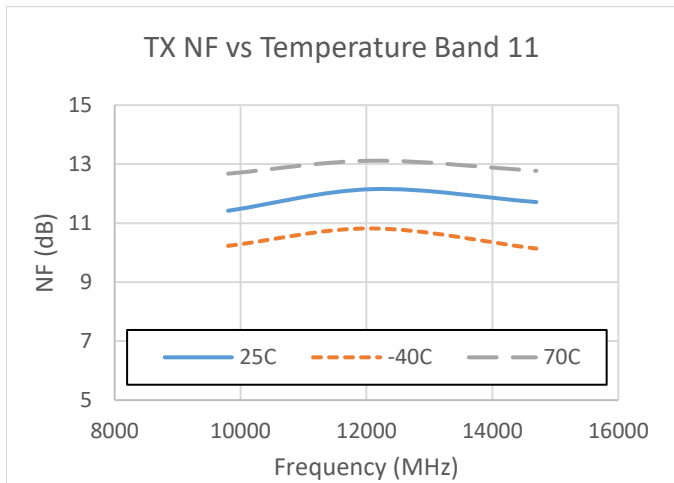
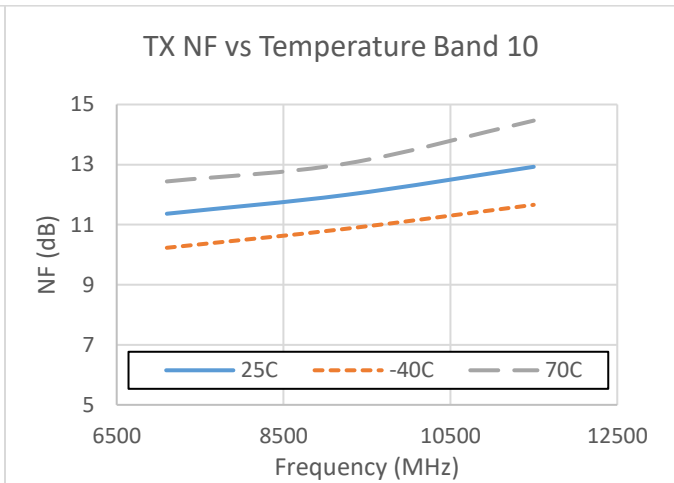
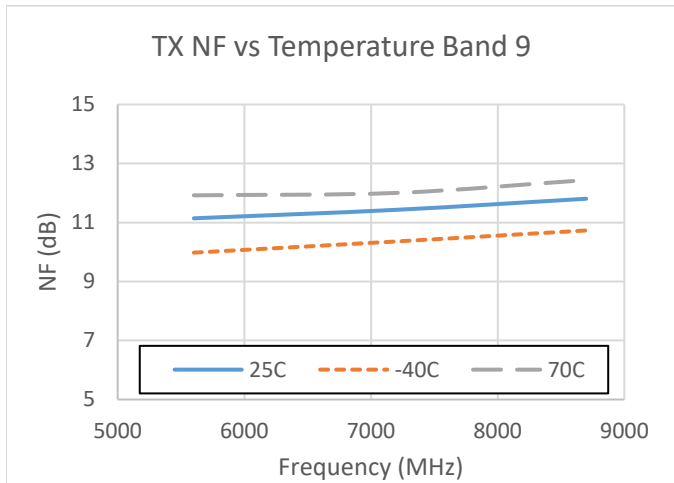
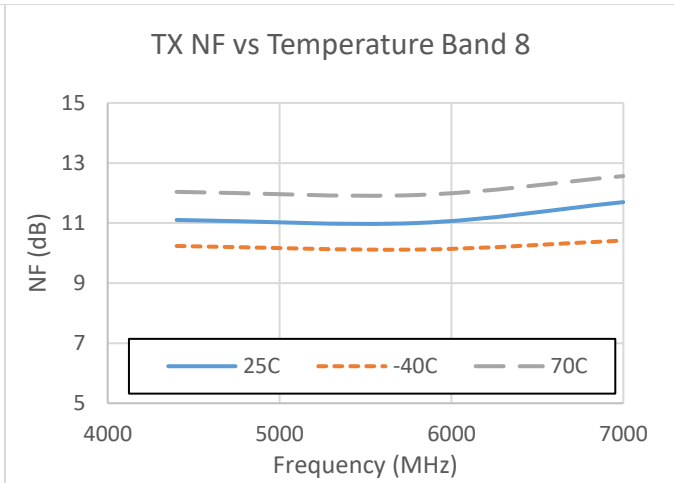
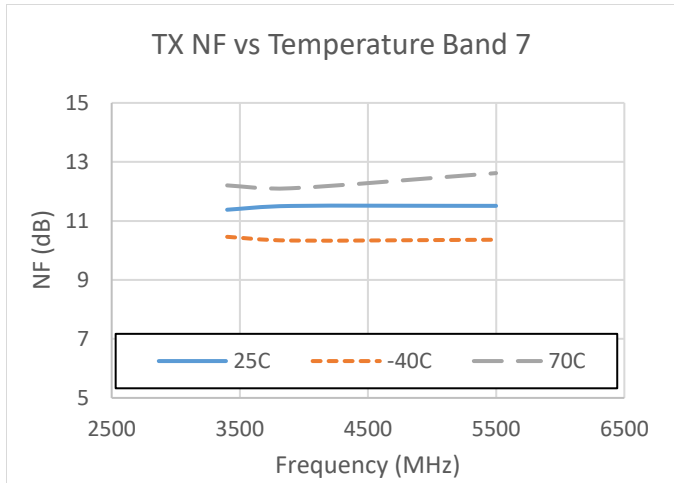

TX OIP3 Versus Temperature Bands 1 through 6 (Single Ended)

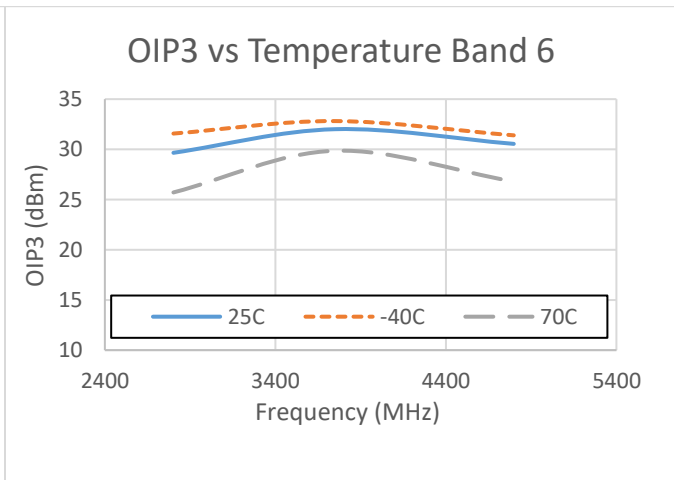
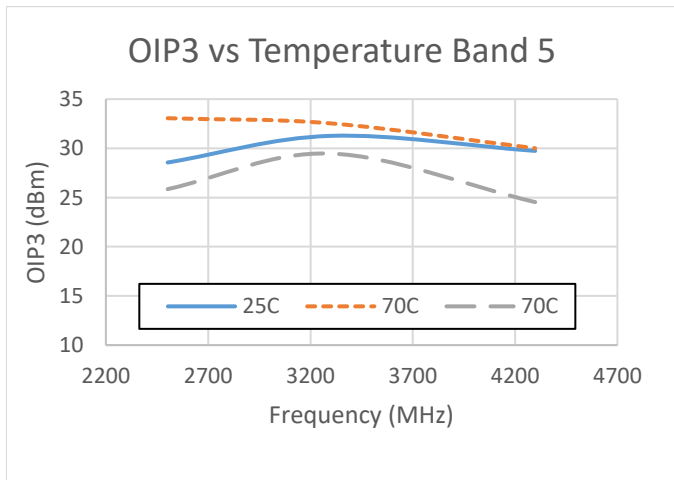
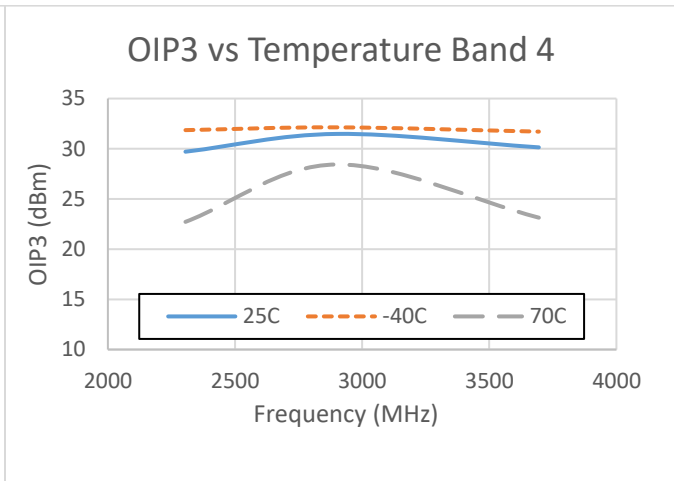
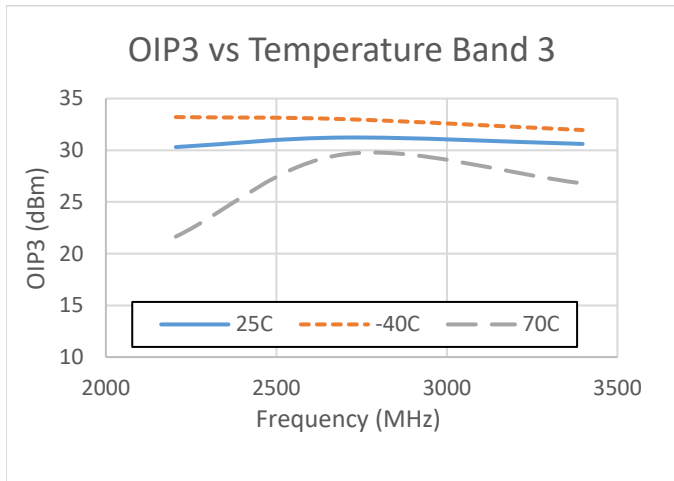
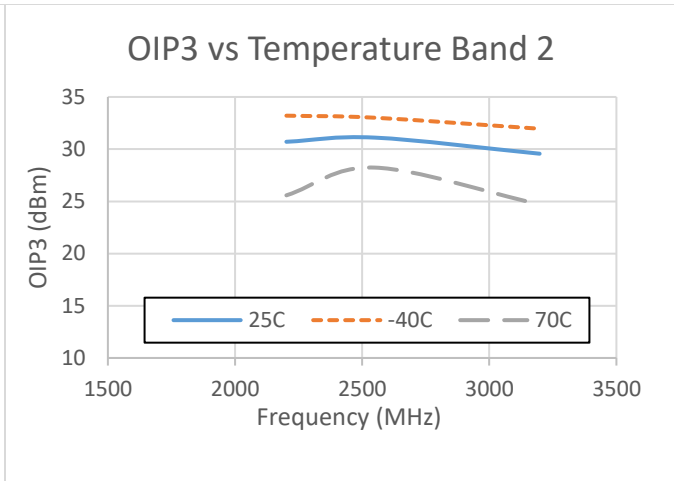
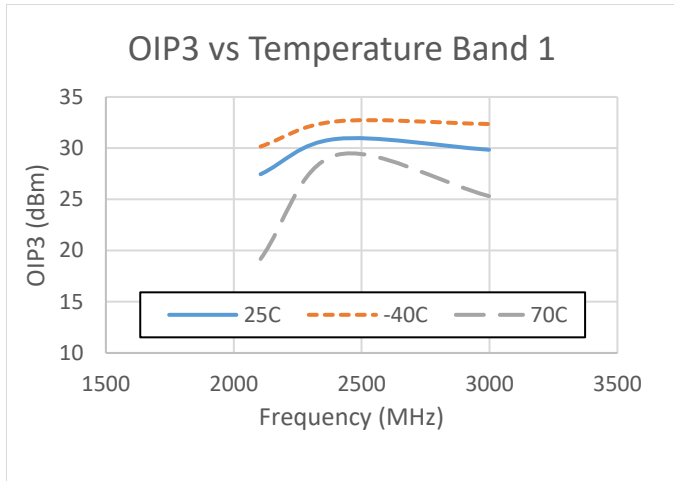

TX OIP3 Versus Temperature Bands 7 through 12 (Single Ended)

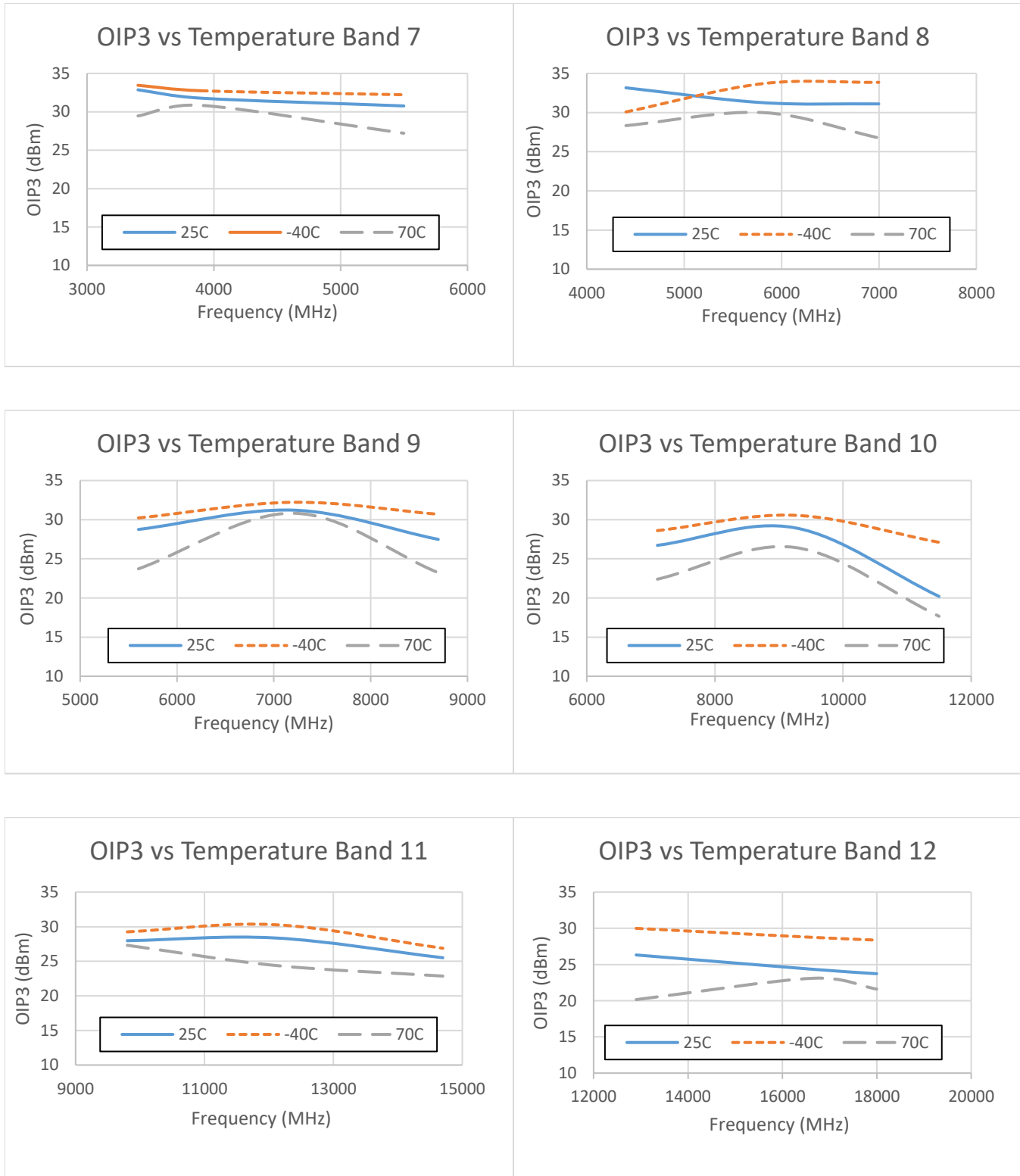

Typical Bypass Performance

(Single Ended RX to RX Isolation Input Referred)

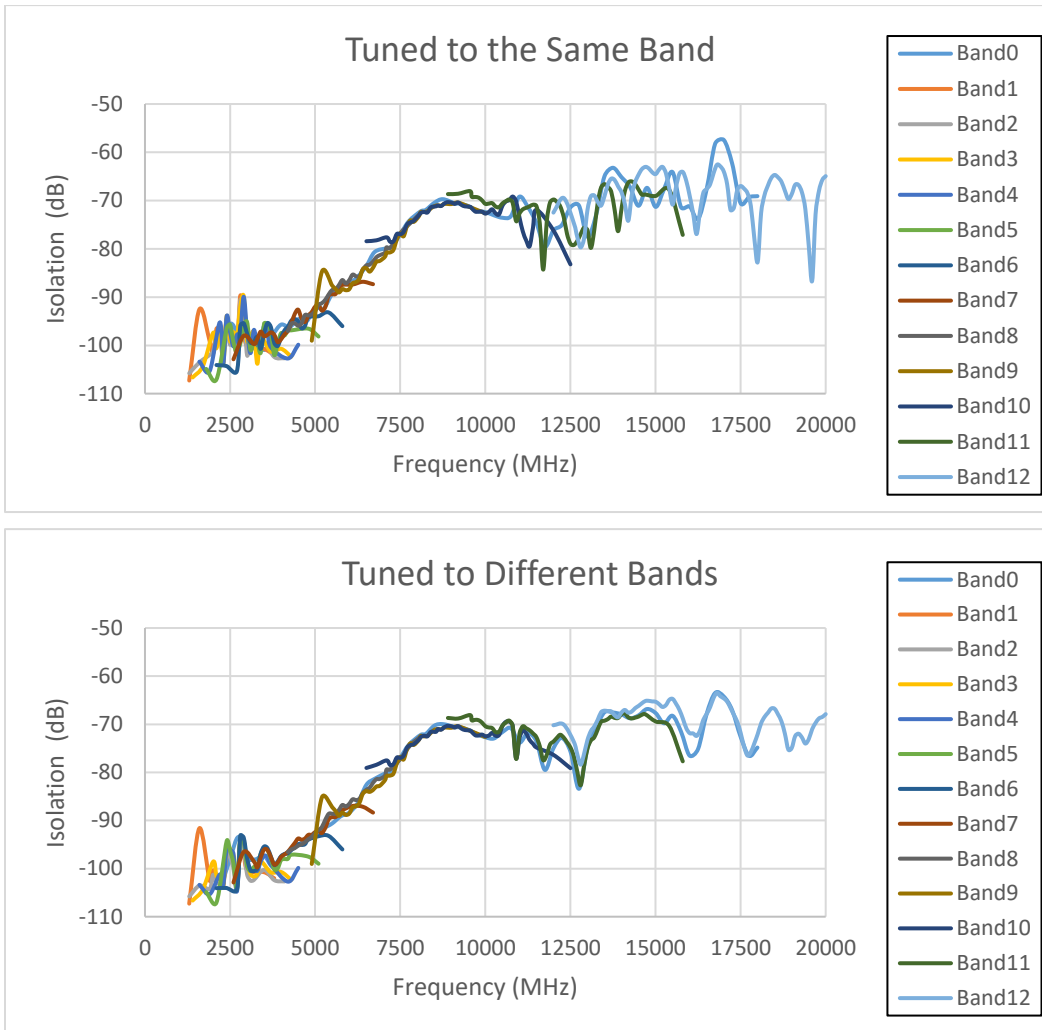

Note: Temperatures in plots are ambient temperatures, case temperatures delta would be approximately +15 degrees Celsius in standing air.



Corporate Headquarters

50 Minuteman Road
Andover, MA 01810 USA
+1 978.967.1401 tel
+1 866.627.6951 tel
+1 978.256.3599 fax

International Headquarters

Mercury International

Avenue Eugène-Lance, 38
PO Box 584
CH-1212 Grand-Lancy 1
Geneva, Switzerland
+41 22 884 5100 tel

Learn more

Visit: mrcy.com

For pricing details, contact: MMICsales@mrcy.com

For technical details, contact: MMICsupport@mrcy.com



The Mercury Systems logo is a registered trademark of Mercury Systems, Inc. Other marks used herein may be trademarks or registered trademarks of their respective holders. Mercury products identified in this document conform with the specifications and standards described herein. Conformance to any such standards is based solely on Mercury's internal processes and methods. The information contained in this document is subject to change at any time without notice.



© 2026 Mercury Systems, Inc. 2.1 -0-2026-05-28-DS- AM3269