

AM3056 – Filter

1 GHz Final IF Bandpass Filter

Description

AM3056 is a passive bandpass filter implemented on chip that provides low loss and high rejection in a small 5mm package. With a center frequency of 1 GHz and a bandwidth of 500 MHz, AM3056 is useful as an IF filter in any RF system for image, LO, and spur rejection. AM3056 is AC coupled and matched to 50 ohms while operating over the -40C to +100C temperature range.

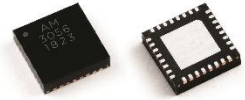

Features

- Fixed 1 GHz Center Frequency
- 500 MHz Bandwidth
- >35 dB Stopband Rejection Typ.
- 1 dB Passband Flatness Typ.
- 0.5 W Power Handling
- 5mm QFN Package
- -40C to +100C Operation

Functional Diagram

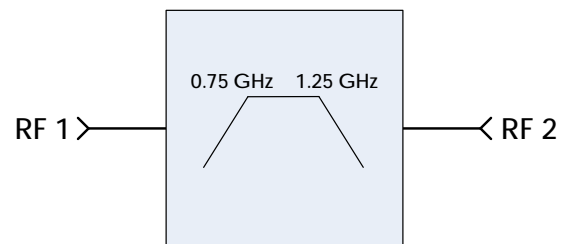

Characteristic Performance

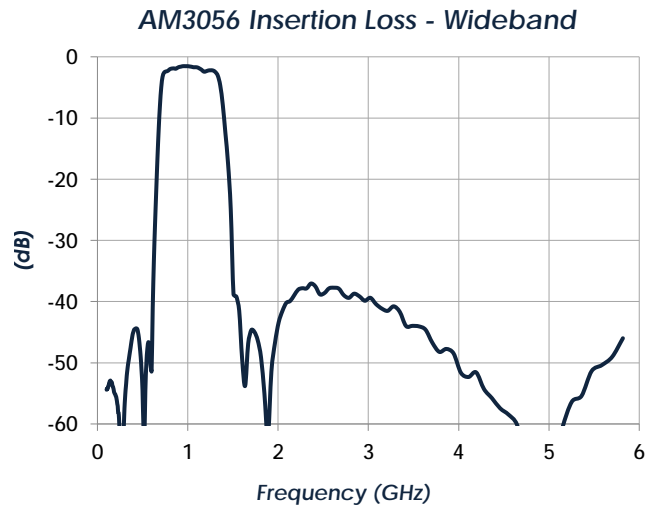
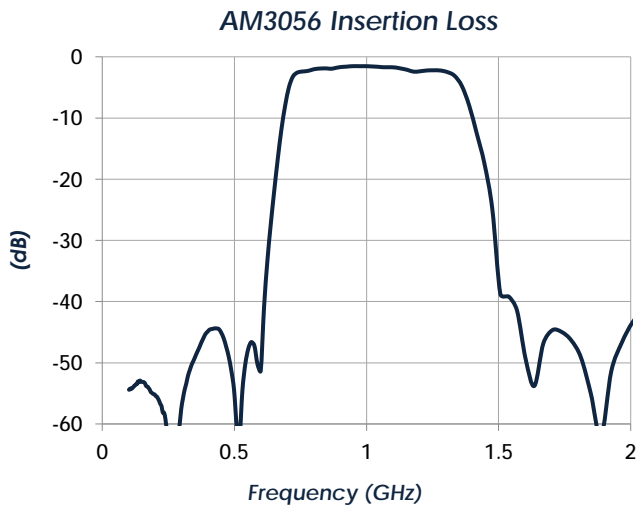

AM3056 – Filter

1 GHz Final IF Bandpass Filter

Table of Contents

Description	1	Recommended Operating Conditions ...	4
Features	1	RF Performance	4
Functional Diagram	1	Typical Performance	5
Characteristic Performance	1	Typical Application	6
Revision History	2	Evaluation PC Board	7
Pin Layout and Definitions	3	Part Ordering Details	7
Specifications	4	Related Parts	7
Absolute Maximum Ratings	4	Component Compliance Information	8
Handling Information	4		

Revision History

Date	Revision Number	Notes
June 23, 2021	1	Initial release

Pin Layout and Definitions

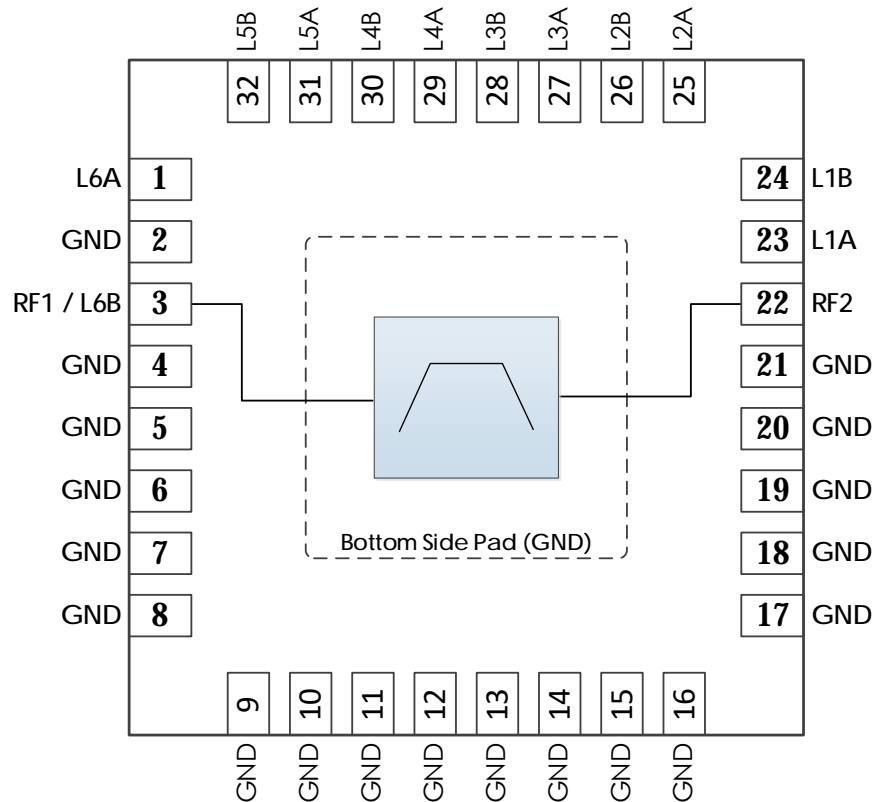

Pin Number	Pin Name	Pin Function
1	L6A	External Inductor L6 connection
2	GND	Ground - Common
3	RF1 / L6B	RF Port 1 and external inductor L6 connection. RF1 is 50 ohms and AC coupled. See Typical Application for connection details.
4 – 21	GND	Ground – Common
22	RF2	RF Port 2 – 50 ohms, AC coupled.
23	L1A	External inductor L1 connection
24	L1B	External inductor L1 connection
25	L2A	External inductor L2 connection
26	L2B	External inductor L2 connection
27	L3A	External inductor L3 connection
28	L3B	External inductor L3 connection
29	L4A	External inductor L4 connection
30	L4B	External inductor L4 connection
31	L5A	External inductor L5 connection
32	L5B	External inductor L5 connection

AM3056 – Filter

1 GHz Final IF Bandpass Filter

Specifications

Absolute Maximum Ratings

	Minimum	Maximum
RF Input Power		+27 dBm
Operating Junction Temperature	-40 C	+150 C
Storage Temperature Range	-55 C	+150 C

Note: Any device operation beyond the Absolute Maximum Ratings may result in permanent damage to the device. The values listed in this table are extremes and do not imply functional operation of the device at these or any other conditions beyond what is listed under Recommended Operating Conditions. Any part subjected to conditions outside of what is recommended for an extended amount of time may suffer from reliability concerns.

Handling Information

	Minimum	Maximum
Storage Temperature Range (Recommended)	-50 C	+125 C
Moisture Sensitivity Level	MSL 3	



Atlanta Micro products are electrostatic sensitive.
Follow safe handling practices to avoid damage.

Recommended Operating Conditions

	Minimum	Typical	Maximum
Operating Case Temperature	-40 C		+100 C
Operating Junction Temperature	-40 C		+125 C

RF Performance

(T = 25 °C unless otherwise specified)

Parameter	Testing Conditions	Minimum	Typical	Maximum
Passband Range		0.75 GHz		1.25 GHz
Bandwidth			500 MHz	
Passband Flatness			1 dB	
Stopband Rejection		35 dB		
Insertion Loss	f = 0.75 GHz		2.6 dB	
	f = 1.00 GHz		1.5 dB	
	f = 1.25 GHz		2.2 dB	
Return Loss	f = 0.75 GHz		23 dB	
	f = 1.00 GHz		27 dB	
	f = 1.25 GHz		9.6 dB	

AM3056 – Filter

1 GHz Final IF Bandpass Filter

Typical Performance

(T = 25 °C unless otherwise specified. Refer to s-parameters available for download on Atlanta Micro website for more information)

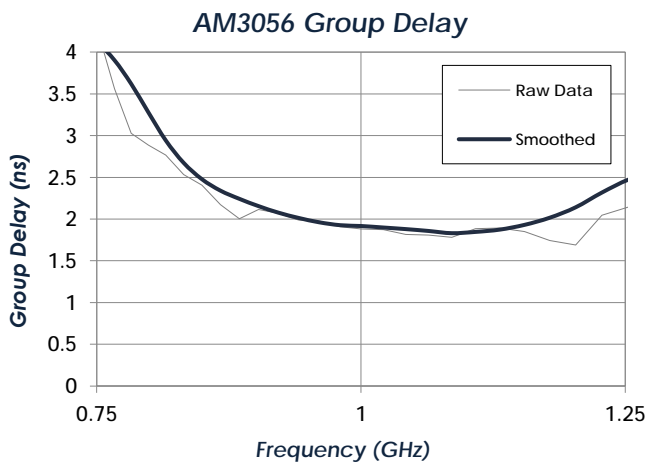
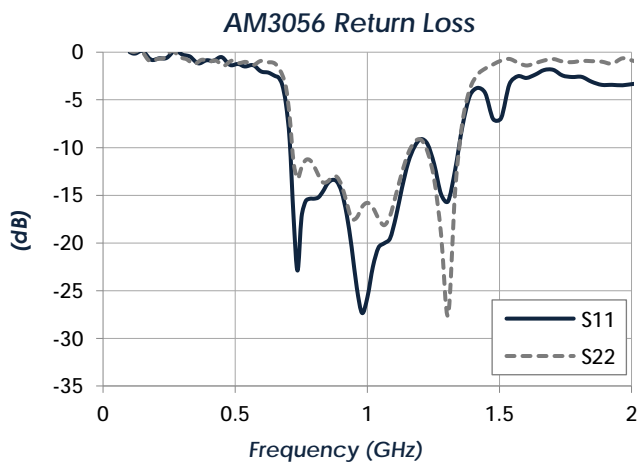
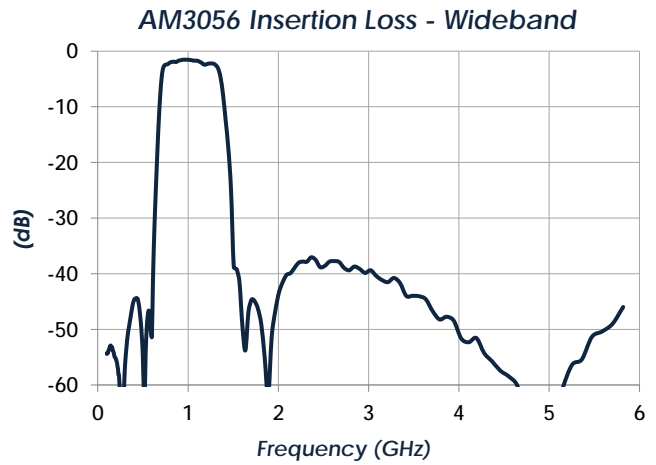
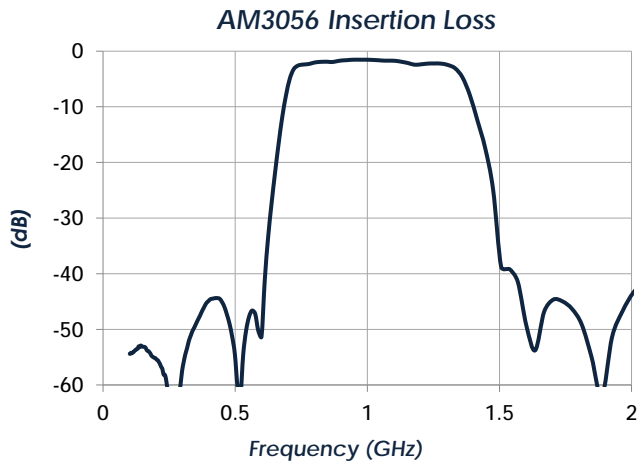

AM3056 – Filter

1 GHz Final IF Bandpass Filter

Typical Application

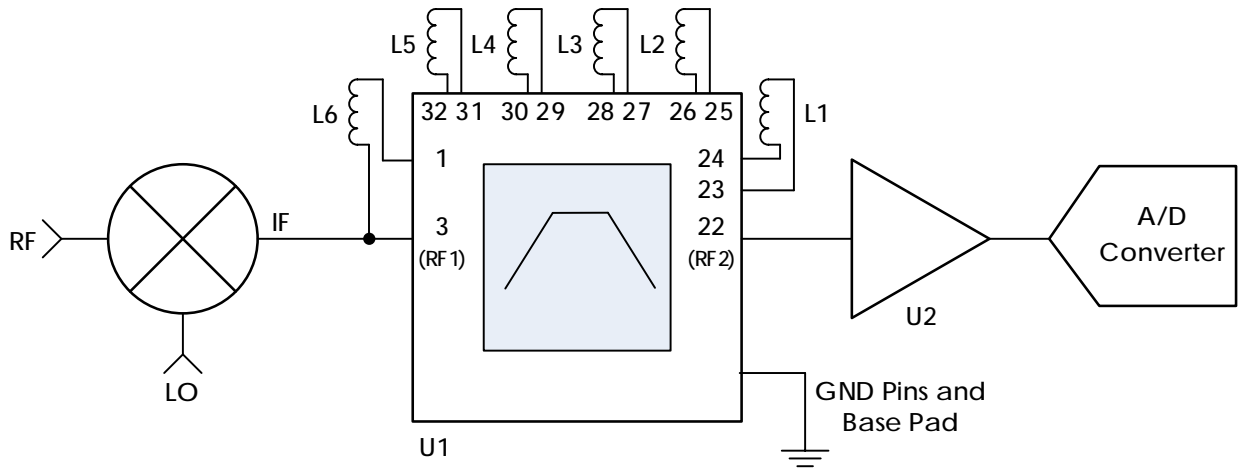

Recommended Component List (or equivalent):

Part	Value	Part Number	Manufacturer
U1	-	AM3056	Atlanta Micro
U2	-	AM1090-2	Atlanta Micro
L1	16 nH	0402DC-16NXGRU	Coilcraft
L2	7.5 nH	0402DC-7N5XGRU	Coilcraft
L3	15 nH	0402DC-15NXGRU	Coilcraft
L4	4.8 nH	0402DC-4N8XGRU	Coilcraft
L5	4.1 nH	0402DC-4N1XGRU	Coilcraft
L6	4.9 nH	0402DC-4N9XGRU	Coilcraft

Notes:

1. L1 – L6 should be placed close to AM3056 for best performance.

AM3056 – Filter

1 GHz Final IF Bandpass Filter

Evaluation PC Board

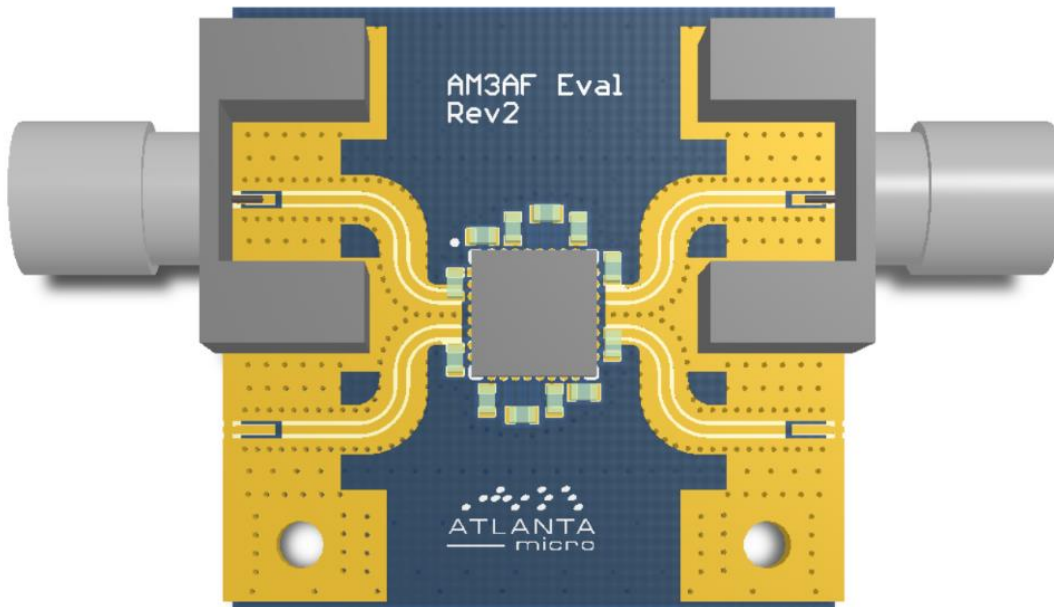

Part Ordering Details

Description	Part Number
5mm x 5mm x 1.2mm QFN package	AM3056
AM3056 Evaluation Board with Connectors	AM3056 Eval

Related Parts

Part Number	Description
AM3055	1.5 GHz to 2.5 GHz Bandpass
AM3188	2.5 GHz to 3.5 GHz Bandpass
AM3187	3.25 GHz to 4.25 GHz Bandpass
AM3103	1 GHz to 3 GHz Digitally Tunable Bandpass

To obtain price, delivery, or to place an order contact MMICSales@mercy.com
 Atlanta Micro Inc., 3720 Davinci Ct, Suite 400, Peachtree Corners, GA 30092 • Phone: (470) 253-7640 • www.atlantamicro.com

Component Compliance Information

RoHS: Atlanta Micro, Inc. hereby certifies that all products comply with the EC Directive 2011/65/EC on the Restriction of Hazardous Substances, commonly known as EU-RoHS 6 and 10. All products supplied by Atlanta Micro shall be compliant with the European Directive 2011/65/EC based on the following substance list.

Substance List	Allowable Maximum Concentration
Lead (Pb)	<1000 PPM (0.1% by weight)
Mercury (Hg)	<1000 PPM (0.1% by weight)
Cadmium (Cd)	<75 PPM (0.0075% by weight)
Hexavalent Chromium (CrVI)	<1000 PPM (0.1% by weight)
Polybrominated Biphenyls (PBB)	<1000 PPM (0.1% by weight)
Polybrominated Diphenyl ethers (PBDE)	<1000 PPM (0.1% by weight)
Decabromodiphenyl Deca BDE	<1000 PPM (0.1% by weight)
Bis (2-ethylhexyl) Phthalate (DEHP)	<1000 PPM (0.1% by weight)
Butyl Benzyl Phthalate (BBP)	<1000 PPM (0.1% by weight)
Dibutyl Phthalate (DBP)	<1000 PPM (0.1% by weight)
Diisobutyl Phthalate (DIBP)	<1000 PPM (0.1% by weight)

REACH: Atlanta Micro, Inc. neither uses nor intentionally adds any of the substances considered to be a Substance of Very High Concern (SVHC) as defined by the EU Regulation (EC) No. 1907-2006 on Registration, Evaluation, Authorization, and Restriction of Chemicals (REACH).

Conflict Materials: Atlanta Micro does not knowingly use materials that are sourced from the Democratic Republic of Congo (DRC) or any other known conflict regions. Atlanta Micro's supply chain is comprised of sources that are both environmentally and socially responsible. We periodically review this requirement with our vendors to ensure continued compliance.

Atlanta Micro takes its responsibility as a global partner seriously and will use due diligence within our supply chain to ensure all standards are met to the best of our knowledge.