

### Description

The AM1145 is a wideband digitally controlled variable slope amplifier that covers the 2-18GHz frequency range. The device exhibits low gain at the lower frequencies ascending to higher gain levels at higher frequencies. The increasing gain makes it an ideal solution to equalize gain/insertion loss across an RF system. The AM1145 has four different slope options to allow flexibility in achieving maximum gain flatness in a system while providing unchanged nonlinear performance. It is packaged in a 3mm QFN with internal 50Ω matching and draws 200mW of DC power which makes the AM1145 ideal for demanding, low SWaP applications.

### Features

- 2 dB Gain Slope Variation
- 6 dB Gain at 2 GHz
- 8-10 dB Gain at 18 GHz
- +28 dBm OIP3
- +16 dBm P1dB
- 200 mW DC Power Consumption
- +3.3V VDD and Control
- 3mm QFN Package
- -40C to 85C Operation
- Unconditionally Stable

### Functional Diagram

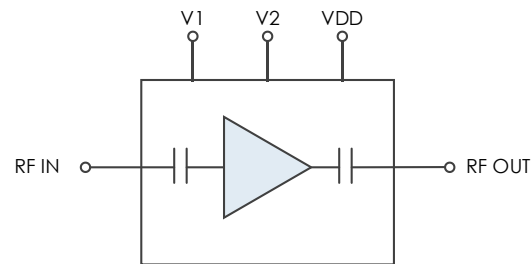

### Characteristic Performance

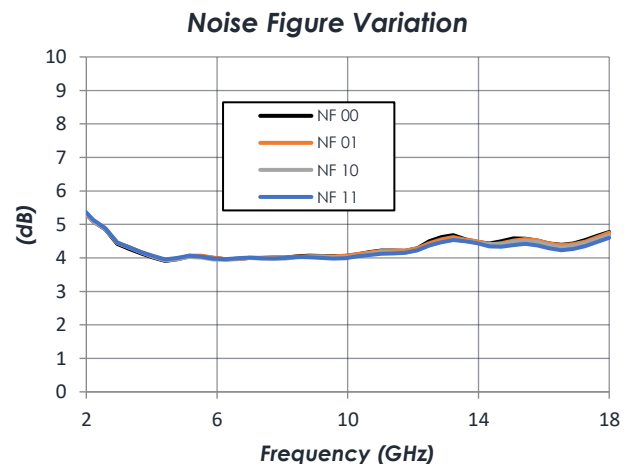
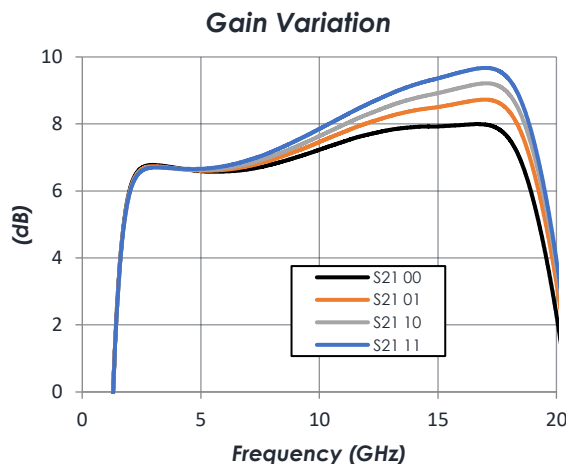

To obtain price, delivery, or to place an order contact [sales@atlantamicro.com](mailto:sales@atlantamicro.com)  
Atlanta Micro Inc., Now a part of Mercury Systems  
3720 Davinci Ct, Suite 400, Peachtree Corners, GA 30092 • Phone: (470) 253-7640 • [www.atlantamicro.com](http://www.atlantamicro.com)

### Table of Contents

<b>Description</b> .....	1	Thermal Information .....	4
<b>Features</b> .....	1	DC Electrical Characteristics .....	5
<b>Functional Diagram</b> .....	1	RF Performance .....	5
<b>Characteristic Performance</b> .....	1	Timing Characteristics .....	5
<b>Revision History</b> .....	2	State Table .....	6
<b>Pin Layout and Definitions</b> .....	3	Typical Performance .....	7
<b>Specifications</b> .....	4	<b>Typical Application</b> .....	10
Absolute Maximum Ratings .....	4	<b>Evaluation PC Board</b> .....	11
Handling Information .....	4	<b>Related Parts</b> .....	11
Recommended Operating Conditions .....	4	<b>Component Compliance Information</b> .....	12

### Revision History

Date	Revision Number	Notes
March 17, 2022	1	Initial Release

# AM1145 – Amplifier

## 2 to 18 GHz Variable Positive Gain Slope Amplifier

### Pin Layout and Definitions

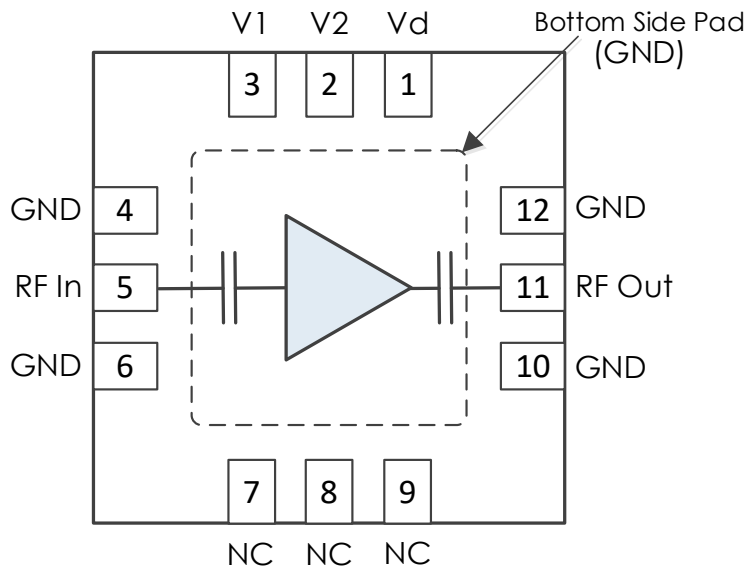

Pin Number	Pin Name	Pin Function
1	Vd	DC Power Input
2	V2	Control Voltage 2
3	V1	Control Voltage 1
4	GND	Ground – Common
5	RF In	RF Input – 50 Ohms – AC Coupled
6	GND	Ground – Common
7-9	NC	No Connect*
10	GND	Ground – Common
11	RF Out	RF Output – 50 Ohms – AC Coupled
12	GND	Ground – Common

\*Note: NC pins may be grounded or left floating.

# AM1145 – Amplifier

## 2 to 18 GHz Variable Positive Gain Slope Amplifier

### Specifications

#### Absolute Maximum Ratings

	Minimum	Maximum
Supply Voltage	-0.3 V	+3.6 V
RF Input Power		20 dBm
Storage Temperature Range	-55 C	+150 C

**Note:** Any device operation beyond the Absolute Maximum Ratings may result in permanent damage to the device. The values listed in this table are extremes and do not imply functional operation of the device at these or any other conditions beyond what is listed under Recommended Operating Conditions. Any part subjected to conditions outside of what is recommended for an extended amount of time may suffer from reliability concerns.

#### Handling Information

	Minimum	Maximum
Moisture Sensitivity Level	MSL 3	



Atlanta Micro products are electrostatic sensitive.  
Follow safe handling practices to avoid damage

#### Recommended Operating Conditions

	Minimum	Typical	Maximum
Supply Voltage		+3.3 V	
Operating Case Temperature	-40 C		+85 C

#### Thermal Information

Junction to Case Thermal Resistance ( $\theta_{JC}$ )	331 C/W
Nominal Junction Temperature at +85C Ambient	150 C
Channel Temperature to Maintain 1 Million Hour MTF	175 C

# AM1145 – Amplifier

## 2 to 18 GHz Variable Positive Gain Slope Amplifier

### DC Electrical Characteristics

(T = 25 °C unless otherwise specified)

Parameter	Testing Conditions	Minimum	Typical	Maximum
DC Supply Voltage			+3.3 V	
DC Supply Current	All States, VDD = +3.3 V		60 mA	
Power Dissipated	VDD = +3.3 V		200 mW	
Logic Level Low		-0.1 V		+0.4 V
Logic Level High		+2.2 V		+VDD
DC Control Current	VDD = +3.3 V		<100 $\mu$ A	

### RF Performance

(T = 25 °C unless otherwise specified)

Parameter	Testing Conditions	Minimum	Typical	Maximum
Frequency Range		2 GHz		18 GHz
Gain	State 00, f=2GHz		6 dB	
	State 01, f=2GHz		6 dB	
	State 10, f=2GHz		6 dB	
	State 11, f=2GHz		6 dB	
	State 00, f=18GHz		7.9 dB	
	State 01, f=18GHz		8.6 dB	
	State 10, f=18GHz		9 dB	
	State 11, f=18GHz		9.5 dB	
Return Loss	f = 10GHz		-15 dB	
Output IP3	f = 10GHz		+28 dBm	
Output P1dB	f = 10GHz		+16.4 dBm	
Noise Figure	f = 10GHz		4.0 dB	

**\*Note:** OIP3 measured with 10MHz tone spacing

### Timing Characteristics

(T = 25 °C unless otherwise specified)

Parameter	Minimum	Typical	Maximum
Switching Speed		20 ns	

**\*Note:** Timing Characteristics measured from 50% control to 90% RF

# AM1145 – Amplifier

## 2 to 18 GHz Variable Positive Gain Slope Amplifier



### State Table

V1	V2	State
Low	Low	2 dB Gain Slope
Low	High	2.7 dB Gain Slope
High	Low	3.1 dB Gain Slope
High	High	3.7 dB Gain Slope

---

To obtain price, delivery, or to place an order contact [sales@atlantamicro.com](mailto:sales@atlantamicro.com)  
Atlanta Micro Inc., Now a part of Mercury Systems  
3720 Davinci Ct, Suite 400, Peachtree Corners, GA 30092 • Phone: (470) 253-7640 • [www.atlantamicro.com](http://www.atlantamicro.com)

# AM1145 – Amplifier

## 2 to 18 GHz Variable Positive Gain Slope Amplifier

### Typical Performance

(T = 25 °C unless otherwise specified)

#### Gain Variation

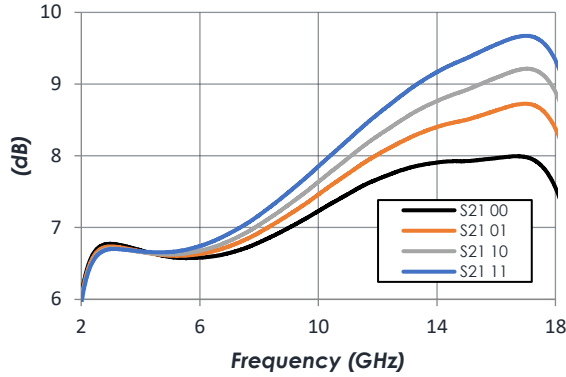

#### Noise Figure Variation

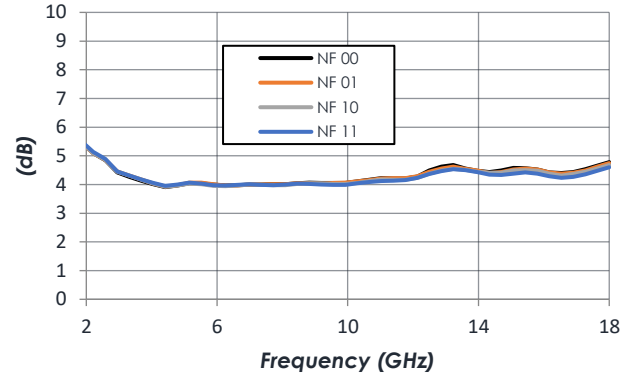

#### Input Return Loss Variation

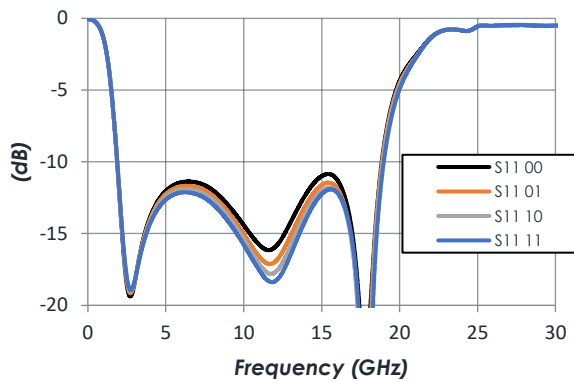

#### Output Return Loss Variation

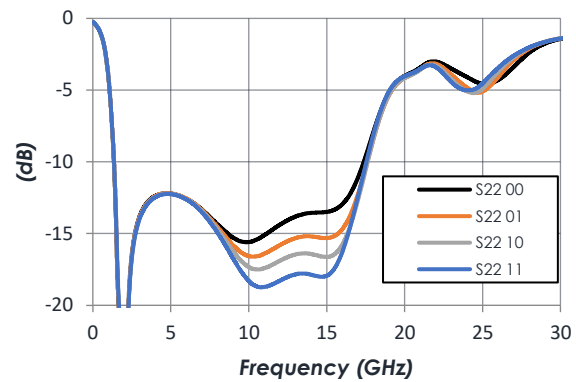

#### OIP3 Variation

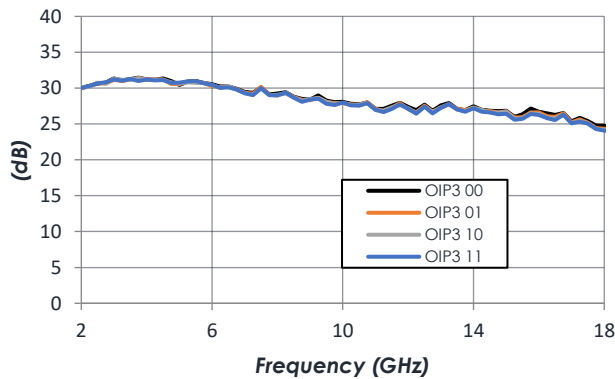

#### P1dB Variation

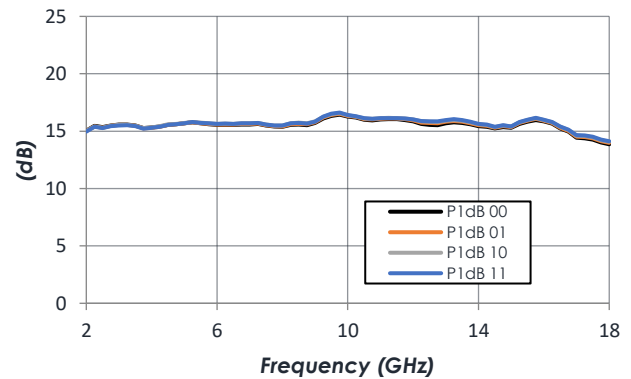

To obtain price, delivery, or to place an order contact [sales@atlantamicro.com](mailto:sales@atlantamicro.com)  
Atlanta Micro Inc., Now a part of Mercury Systems  
3720 Davinci Ct, Suite 400, Peachtree Corners, GA 30092 • Phone: (470) 253-7640 • [www.atlantamicro.com](http://www.atlantamicro.com)

# AM1145 – Amplifier

## 2 to 18 GHz Variable Positive Gain Slope Amplifier

### Typical Performance (continued)

(T = 25 °C unless otherwise specified)

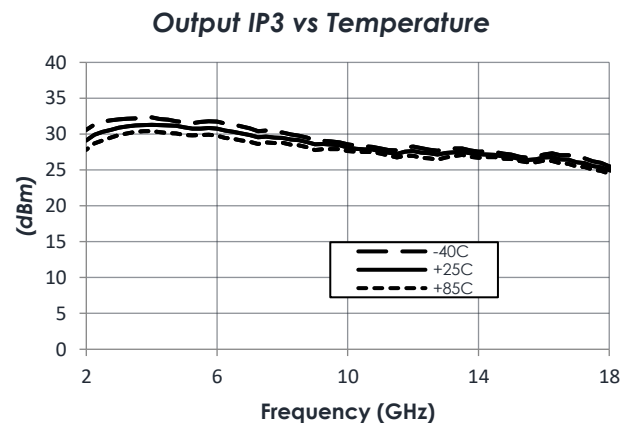
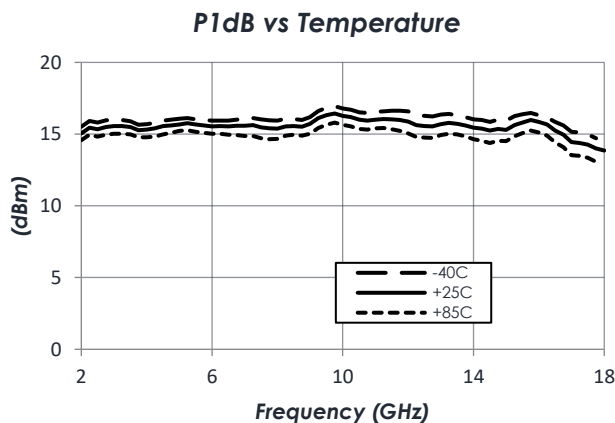
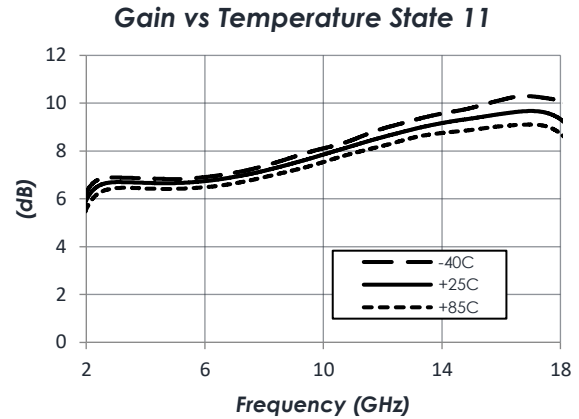
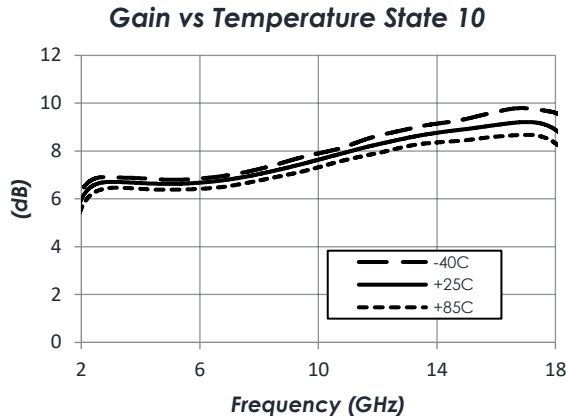
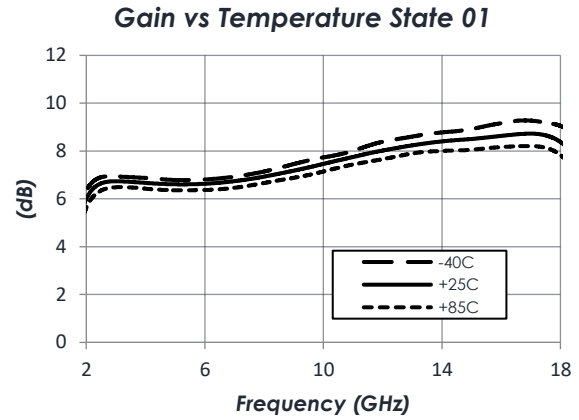
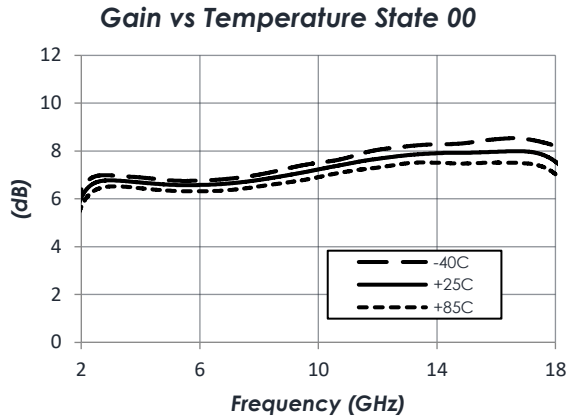

To obtain price, delivery, or to place an order contact [sales@atlantamicro.com](mailto:sales@atlantamicro.com)  
Atlanta Micro Inc., Now a part of Mercury Systems  
3720 Davinci Ct, Suite 400, Peachtree Corners, GA 30092 • Phone: (470) 253-7640 • [www.atlantamicro.com](http://www.atlantamicro.com)



# AM1145 – Amplifier

## 2 to 18 GHz Variable Positive Gain Slope Amplifier

### Typical Performance (continued)

(T = 25 °C unless otherwise specified)

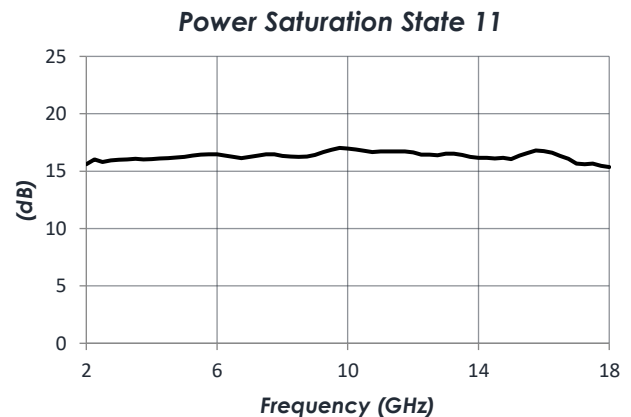
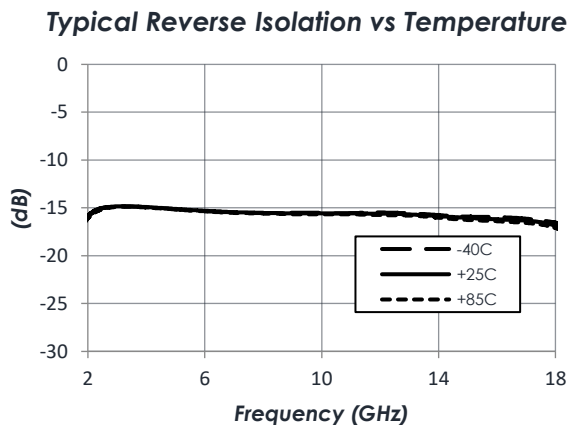
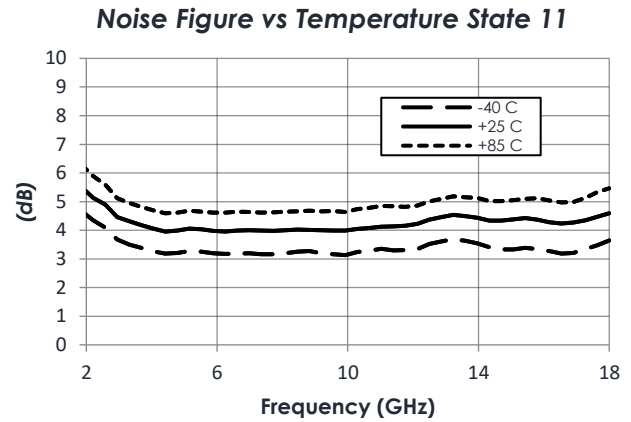
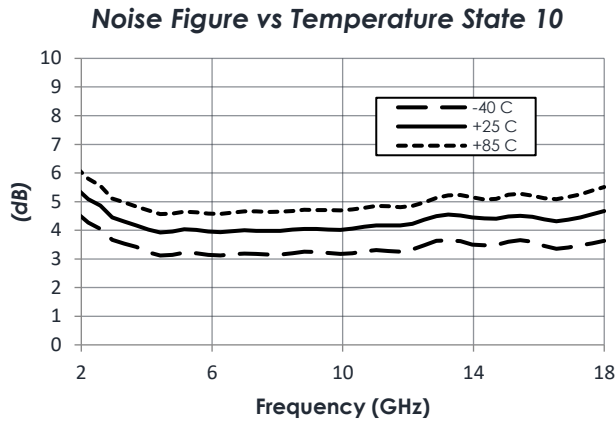
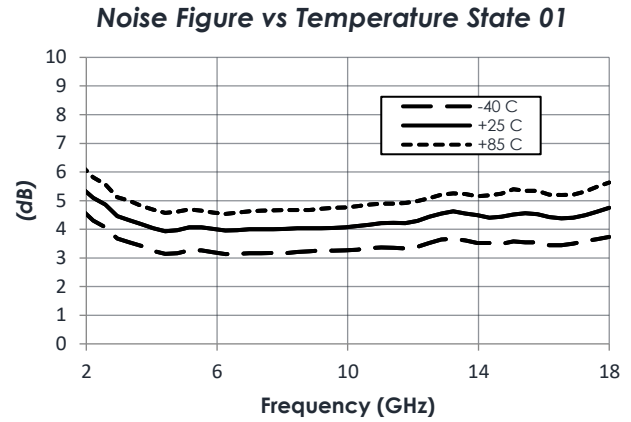
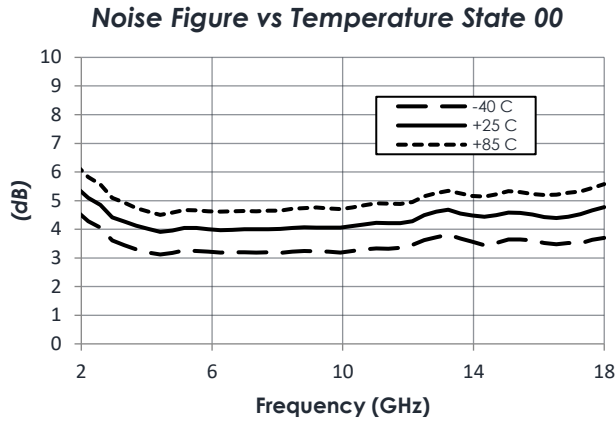

To obtain price, delivery, or to place an order contact [sales@atlantamicro.com](mailto:sales@atlantamicro.com)  
Atlanta Micro Inc., Now a part of Mercury Systems  
3720 Davinci Ct, Suite 400, Peachtree Corners, GA 30092 • Phone: (470) 253-7640 • [www.atlantamicro.com](http://www.atlantamicro.com)

### Typical Application

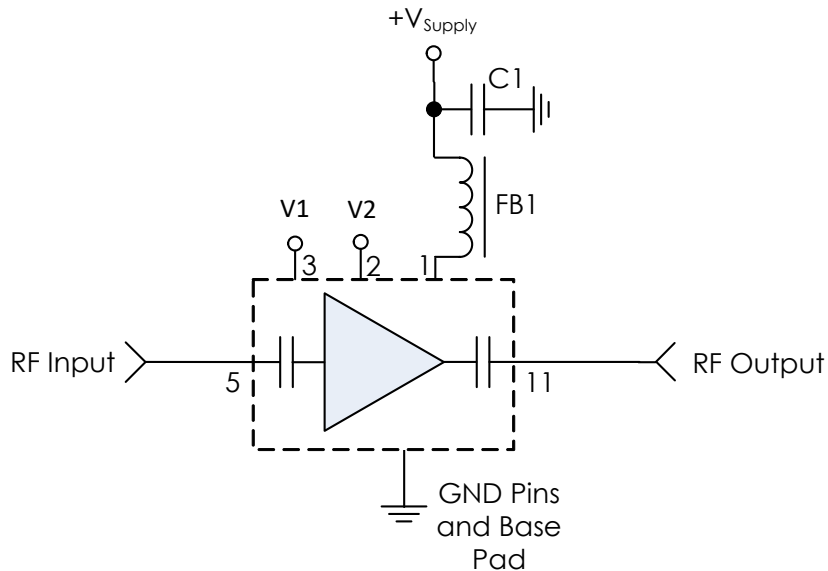

### Recommended Component List (or equivalent):

Part	Value	Part Number	Manufacturer
C1	0.1 $\mu$ F	C1005X7R1H104K05BB	TDK
FB1	-	MMZ1005A222E	TDK

### Notes:

1. Control lines are filtered internally providing high frequency isolation.
2. AM1145 is AC coupled. No external DC blocking caps are required.

# AM1145 – Amplifier

2 to 18 GHz Variable Positive Gain Slope Amplifier

## Evaluation PC Board

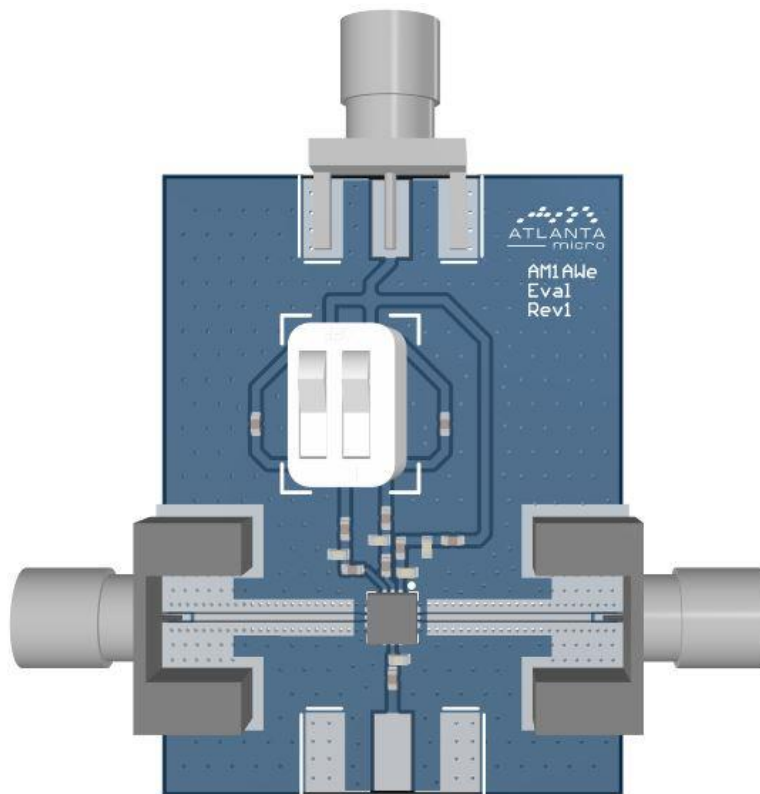

## Related Parts

Part Number	Description
AM1102	DC to 22 GHz Low Noise Amplifier
AM1110	2 GHz to 18 GHz Slope Correcting Amplifier
AM1113	2 GHz to 18 GHz Slope Correcting Amplifier
AM1114	2 GHz to 18 GHz Slope Correcting Amplifier
AM1135	6 GHz to 26.5 GHz Variable Gain Amplifier
AM1146	2 GHz to 18 GHz Variable Gain Amplifier

To obtain price, delivery, or to place an order contact [sales@atlantamicro.com](mailto:sales@atlantamicro.com)  
Atlanta Micro Inc., Now a part of Mercury Systems  
3720 Davinci Ct, Suite 400, Peachtree Corners, GA 30092 • Phone: (470) 253-7640 • [www.atlantamicro.com](http://www.atlantamicro.com)

### Component Compliance Information

**RoHS:** Atlanta Micro, Inc. hereby certifies that all products comply with the EC Directive 2011/65/EC on the Restriction of Hazardous Substances, commonly known as EU-RoHS 6 and 10. All products supplied by Atlanta Micro shall be compliant with the European Directive 2011/65/EC based on the following substance list.

Substance List	Allowable Maximum Concentration
Lead (Pb)	<1000 PPM (0.1% by weight)
Mercury (Hg)	<1000 PPM (0.1% by weight)
Cadmium (Cd)	<75 PPM (0.0075% by weight)
Hexavalent Chromium (CrVI)	<1000 PPM (0.1% by weight)
Polybrominated Biphenyls (PBB)	<1000 PPM (0.1% by weight)
Polybrominated Diphenyl ethers (PBDE)	<1000 PPM (0.1% by weight)
Decabromodiphenyl Deca BDE	<1000 PPM (0.1% by weight)
Bis (2-ethylhexyl) Phthalate (DEHP)	<1000 PPM (0.1% by weight)
Butyl Benzyl Phthalate (BBP)	<1000 PPM (0.1% by weight)
Dibutyl Phthalate (DBP)	<1000 PPM (0.1% by weight)
Diisobutyl Phthalate (DIBP)	<1000 PPM (0.1% by weight)

**REACH:** Atlanta Micro, Inc. neither uses nor intentionally adds any of the substances considered to be a Substance of Very High Concern (SVHC) as defined by the EU Regulation (EC) No. 1907-2006 on Registration, Evaluation, Authorization, and Restriction of Chemicals (REACH).

**Conflict Materials:** Atlanta Micro does not knowingly use materials that are sourced from the Democratic Republic of Congo (DRC) or any other known conflict regions. Atlanta Micro's supply chain is comprised of sources that are both environmentally and socially responsible. We periodically review this requirement with our vendors to ensure continued compliance.

Atlanta Micro takes its responsibility as a global partner seriously and will use due diligence within our supply chain to ensure all standards are met to the best of our knowledge.