

# Cobalt 71661

4-channel 200 MHz A/D with DDCs  
XMC module with Virtex-6 FPGA

## Complete radar and software radio interface solution

- Radar and software radio receiver
- Communications receiver
- Analog signal interface for data recording
- Wideband data acquisition
- Remote monitoring
- Sensor interfaces



**The 71661 is a multichannel, high-speed data converter with programmable DDCs (digital downconverters), suitable for connection to HF or IF ports of a communications or radar system.** Its built-in data capture features offer an ideal turnkey solution as well as a platform for developing and deploying custom FPGA processing IP.

It includes four A/Ds and four banks of memory. In addition to supporting PCI Express Gen. 2 as a native interface, the 71661 includes a general-purpose connector for application-specific I/O.

### FEATURES

- Supports Xilinx® Virtex®-6 LXT and SXT FPGA
- Four 200 MHz 16-bit A/Ds
- Four multiband DDCs (digital downconverters)
- Multiband programmable beamformer
- Up to 2 GB of DDR3 SDRAM or 32 MB of QDRII+ SRAM
- Sample clock synchronization to an external system reference
- LVPECL clock/sync bus for multimodule synchronization
- PCI Express (Gen. 1 & 2) interface up to x8
- Optional LVDS connections to the FPGA for custom I/O

71661 BLOCK DIAGRAMS

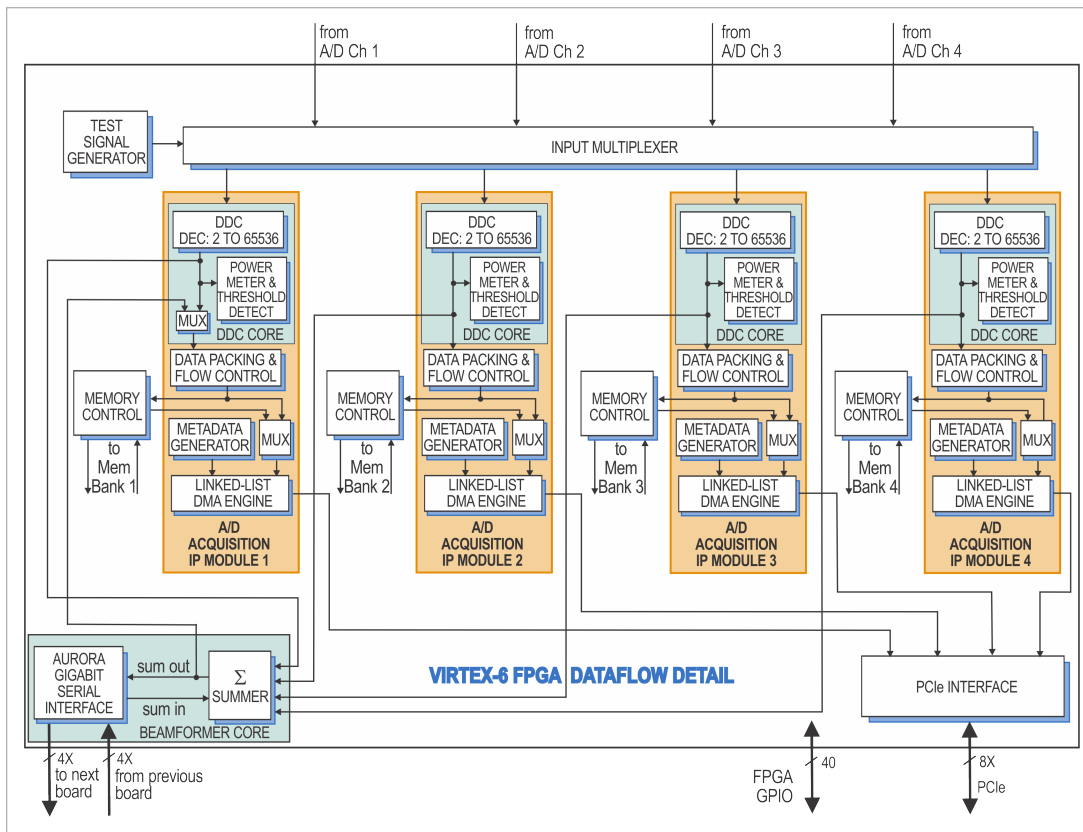
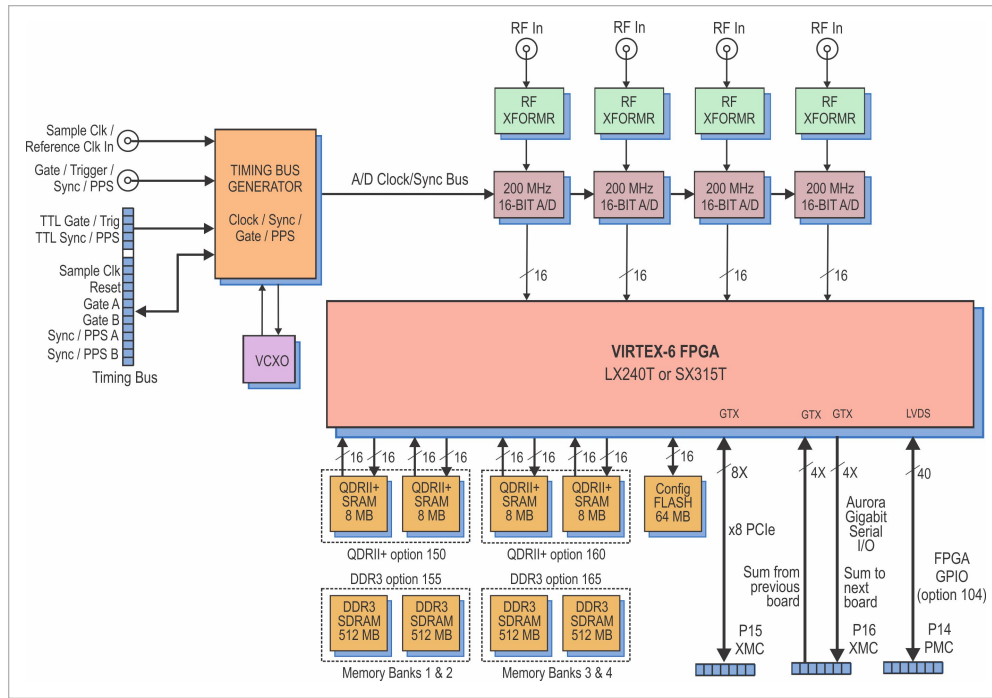

## THE COBALT ARCHITECTURE

The Cobalt® Architecture features a Xilinx Virtex-6 FPGA. All of the board's data and control paths are accessible by the FPGA, enabling factory-installed functions including data multiplexing, channel selection, data packing, gating, triggering and memory control. The Cobalt Architecture organizes the FPGA as a container for data processing applications where each function exists as an intellectual property (IP) module.

Each member of the Cobalt family is delivered with factory-installed applications ideally matched to the board's analog interfaces. The 71661 factory-installed functions include four A/D acquisition IP modules.

Each of the four acquisition IP modules contains a powerful, programmable DDC (Digital Downconverter) IP core. IP modules for either DDR3 or QDR1+ memories, a controller for all data clocking and synchronization functions, a test signal generator, a programmable beamforming IP core, an Aurora gigabit serial interface, and a PCIe interface complete the factory-installed functions and enable the 71661 to operate as a complete turnkey solution without the need to develop any FPGA IP.

## EXTENDABLE IP DESIGN

For applications that require specialized functions, users can install their own custom IP for data processing. The GateFlow FPGA Design Kits include all of the factory-installed modules as document source code. Developers can integrate their own IP with the factory-installed functions or use the GateFlow kit to completely replace the IP with their own.

## XILINX VIRTEX-6 FPGA

The Virtex-6 FPGA site can be populated with two different FPGAs to match the specific requirements of the processing task. Supported FPGAs include: LX240T or SX315T. The SXT part features 1344 DSP48E slices and is ideal for modulation/demodulation, encoding/decoding, encryption/decryption, and channelization of the signals between transmission and reception. For applications not requiring large DSP resources, the lower-cost LXT FPGA can be installed.

## A/D CONVERTER STAGE

The board's analog interface accepts four analog HF or IF inputs on front panel SSMC connectors at +8 dBm into 50 ohms with transformer coupling into four Texas Instruments ADS5485 200 MHz, 16-bit A/D converters.

The digital outputs are delivered into the Virtex-6 FPGA for signal processing, data capture or for routing to other module resources.

## A/D ACQUISITION MODULES

The 71661 features four A/D Acquisition IP Modules for easily capturing and moving data. Each IP module can receive data from any of the four A/Ds or a test signal generator.

Each IP module has an associated memory bank for buffering data in FIFO mode or for storing data in transient capture mode. All memory banks are supported with DMA engines for easily moving A/D data through the PCIe interface. These powerful linked-list DMA engines are capable of a unique Acquisition Gate Driven mode. In this mode, the length of a transfer performed by a link definition need not be known prior to data acquisition; rather, it is governed by the length of the acquisition gate. This is extremely useful in applications where an external gate drives acquisition and the exact length of that gate is not known or is likely to vary.

For each transfer, the DMA engine can automatically construct metadata packets containing A/D channel ID, a sample-accurate time stamp and data length information. These actions simplify the host processor's job of identifying and executing on the data.

## DDC IP CORES

Within each A/D Acquisition IP Module is a powerful DDC IP core. Because of the flexible input routing of the A/D Acquisition IP Modules, many different configurations can be achieved including one A/D driving all four DDCs or each of the four A/Ds driving its own DDC.

Each DDC has an independent 32-bit tuning frequency setting that ranges from DC to  $f_s$ , where  $f_s$  is the A/D sampling frequency. Each DDC can have its own unique decimation setting, supporting as many as four different output bandwidths for the board. Decimations can be programmed from 2 to 65,536 providing a wide range to satisfy most applications.

The decimating filter for each DDC accepts a unique set of user-supplied 18-bit coefficients. The 80% default filters deliver an output bandwidth of  $0.8 * f_s / N$ , where N is the decimation setting. The rejection of adjacent-band components within the 80% output bandwidth is better than 100 dB. Each DDC delivers a complex output stream consisting of 24-bit I + 24-bit Q or 16-bit I + 16-bit Q samples at a rate of  $f_s / N$ .

## BEAMFORMER IP CORE

In addition to the DDCs, the 71661 features a complete beamforming subsystem. Each DDC core contains programmable I & Q phase and gain adjustments followed by a power meter that continuously measures the individual average power output. The time constant of the averaging interval for each meter is programmable up to 8K samples. The power meters present average power measurements for each DDC core output in easy-to-read registers.

In addition, each DDC core includes a threshold detector to automatically send an interrupt to the processor if the average power level of any DDC core falls below or exceeds a programmable threshold.

A programmable summation block provides summing of any of the four DDC core outputs. An additional programmable gain stage compensates for summation change bit growth. A power meter and threshold detect block is provided for the summed output. The output is then directed back into the A/D Acquisition IP Module 1 FIFO for reading over the PCIe. For larger systems, multiple 71661's can be chained together via a built-in Xilinx Aurora gigabit serial interface through the P16 XMC connector. This allows summation across channels on multiple boards.

## CLOCKING AND SYNCHRONIZATION

An internal timing bus provides all timing and synchronization required by the A/D converters. It includes a clock, two sync and two gate or trigger signals. An on-board clock generator receives an external sample clock from the front panel SSMC connector. This clock can be used directly by the A/D or divided by a built-in clock synthesizer circuit. In an alternate mode, the sample clock can be sourced from an on-board programmable voltage-controlled crystal oscillator. In this mode, the front panel SSMC connector can be used to provide a 10 MHz reference clock for synchronizing the internal oscillator.

A front panel 26-pin LVPECL Clock/Sync connector allows multiple modules to be synchronized. In the slave mode, it accepts LVPECL inputs that drive the clock, sync and gate signals. In the master mode, the LVPECL bus can drive the timing signals for synchronizing multiple modules.

Multiple 71661's can be driven from the LVPECL bus master, supporting synchronous sampling and sync functions across all connected boards.

## MEMORY RESOURCES

The 71661 architecture supports up to four independent memory banks which can be configured with all QDRII+ SRAM, DDR3 SDRAM, or as combination of two banks of each type of memory.

Each QDRII+ SRAM bank can be up to 8 MB deep and is an integral part of the module's DMA capabilities, providing FIFO memory space for creating DMA packets. For applications requiring deeper memory resources, DDR3 SDRAM banks can each be up to 512 MB deep. Built-in memory functions include multichannel A/D data capture, tagging and streaming.

In addition to the factory-installed functions, custom user-installed IP within the FPGA can take advantage of the memories for many other purposes.

## PCI EXPRESS INTERFACE

The 71661 includes an industry-standard interface fully compliant with PCI Express Gen. 1 & 2 bus specifications. Supporting PCIe links up to x8, the interface includes multiple DMA controllers for efficient transfers to and from the board.

## XMC INTERFACE

The Model 71661 complies with the VITA 42.0 XMC specification. Two connectors each provide dual 4X links or a single 8X link with up to a 6 GHz bit clock. With dual XMC connectors, the 71661 supports x8 PCIe on the first XMC connector. The second connector is used for the Aurora interface and provides a dedicated board-to board interface for beamforming across multiple modules.

**READYFLOW**

Mercury provides ReadyFlow<sup>®</sup> BSPs (Board Support Packages) for all Cobalt, Onyx, and Flexor products. Available for both Linux and Windows, these packages:

- Provide a path for quick start-up through application completion
- Allow programming at high, intermediate and low levels to meet various needs
- Are illustrated with numerous examples
- Include complete documentation and definitions of all functions
- Include library and example source code.

ReadyFlow BSPs contain C-language examples that can be used to demonstrate the capabilities of Cobalt, Onyx, and Flexor products. These programming examples will help you get an immediate start on writing your own application. They provide sample code that is known to work, giving you a means of verifying that your board set is operational.

**COMMAND LINE INTERFACE**

The Command Line Interface provides access to pre-compiled executable examples that operate the hardware right out of the box, without the need to write any code. Board-specific hardware

operating arguments can be entered in the command line to control parameters: number of channels to enable, sample clock frequency, data transfer size, reference clock frequency, reference clock source, etc.

The Command Line Interface can be used to call an example application from within a larger user application to control the hardware, and parameter arguments are passed to the application for execution. Functions that control data acquisition automatically save captured data to a pre-named host file or are routed to the Signal Analyzer example function for display.

**SIGNAL ANALYZER**

When used with the Command Line Interface, the Signal Analyzer allows users to immediately start acquiring and displaying A/D data. A full-featured analysis tool, the Signal Analyzer displays data in time and frequency domains. Built-in measurement functions display 2nd and 3rd harmonics, THD, and SINAD. Interactive cursors allow users to mark data points and instantly calculate amplitude and frequency of displayed signals.

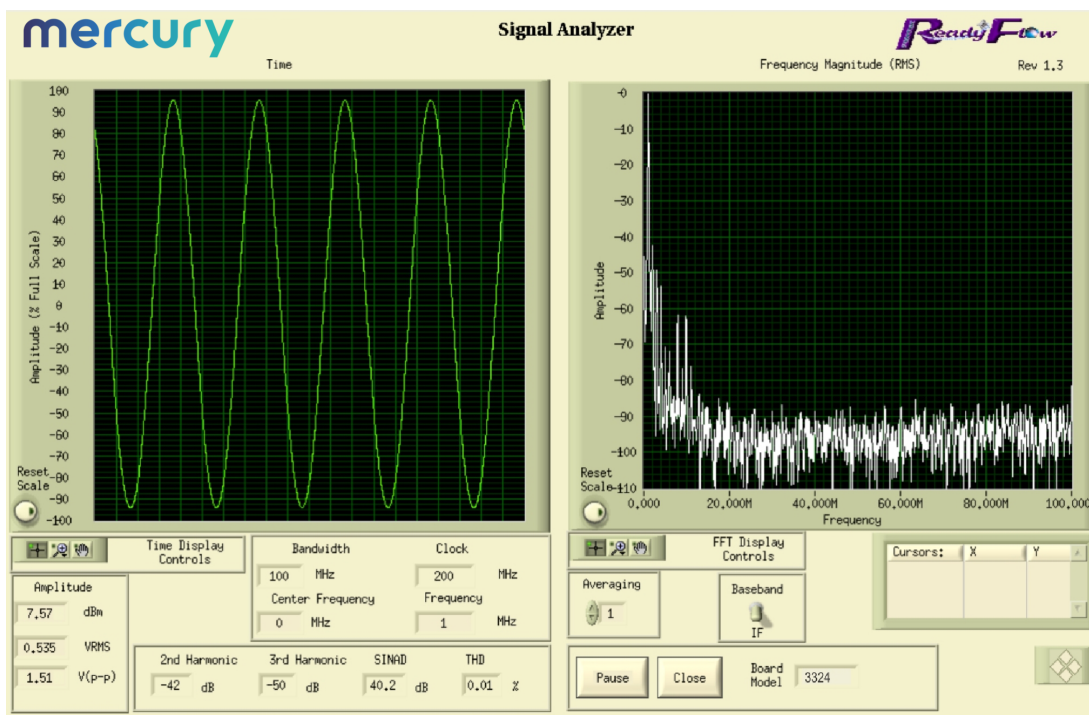

**GATEFLOW**

The GateFlow® FPGA Design Kit (FDK) allows the user to modify, replace and extend the standard installed functions in the FPGA to incorporate special modes of operation, new control structures, and specialized signal-processing algorithms.

The Cobalt (Virtex-6), Onyx (Virtex-7), and Flexor (Virtex-7) architectures configure the FPGA with standard factory-supplied interfaces including memory controllers, DMA engines, A/D and D/A interfaces, timing and synchronization structures, triggering and gating logic, time stamping and header tagging, data formatting engines, and the PCIe interface. These resources are connected to the User Application Container using well-defined ports that present easy-to-use data and control signals, effectively abstracting the lower-level details of the hardware.

**The User Application Container**

Shown below is the FPGA block diagram of a typical Cobalt, Onyx or Flexor module. The User Application Container holds a collection of different installed IP modules connected to the various interfaces through the standard ports surrounding the container. The specific IP modules for each product are described in further detail in the datasheet of that product.

The GateFlow FDK provides a complete Xilinx's ISE or Vivado project folder containing all the files necessary for the FPGA developer to recompile the entire project with or without any required changes. VHDL source code for each IP module provides excellent examples of how the IP modules work, how they might be modified, and how they might be replaced with custom IP to implement a specific function.

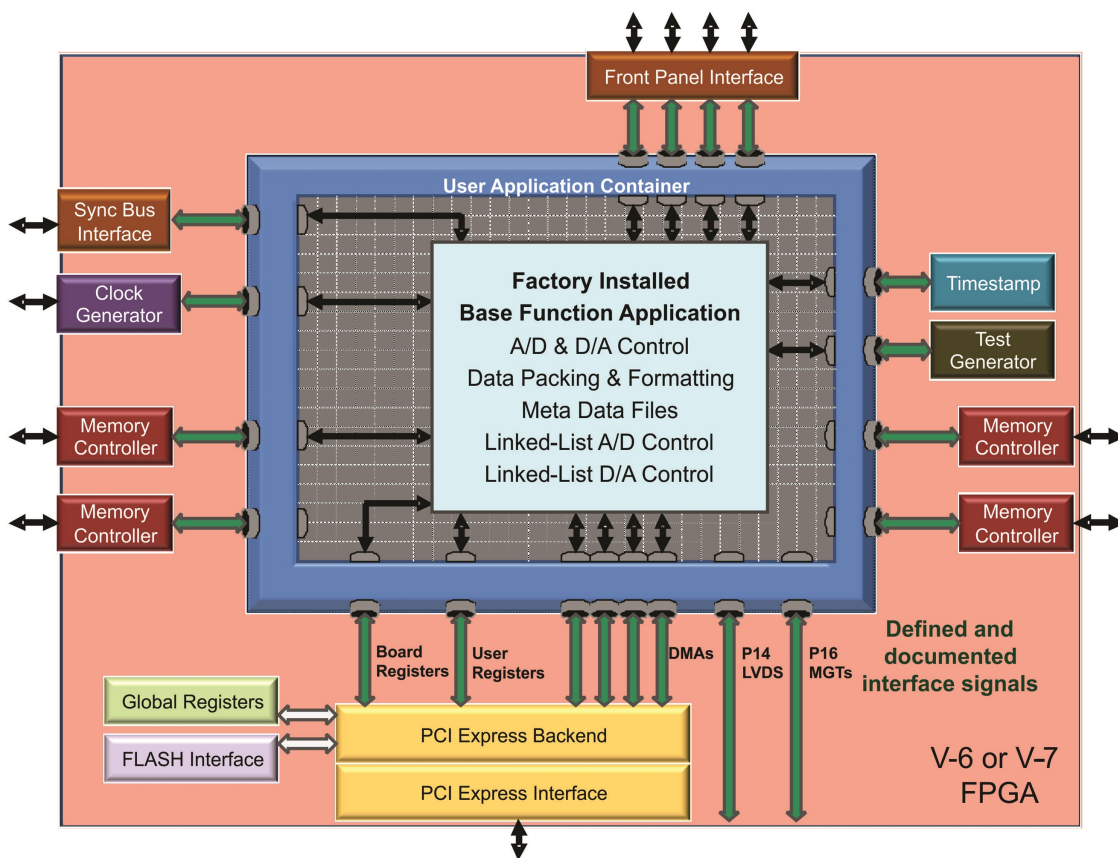

A/D PERFORMANCE

Spurious Free Dynamic Range

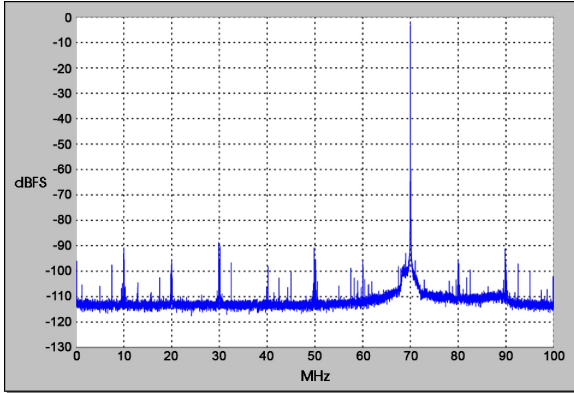

$f_{in} = 70 \text{ MHz}$ ,  $f_s = 200 \text{ MHz}$ , Internal Clock

Spurious Pick-up

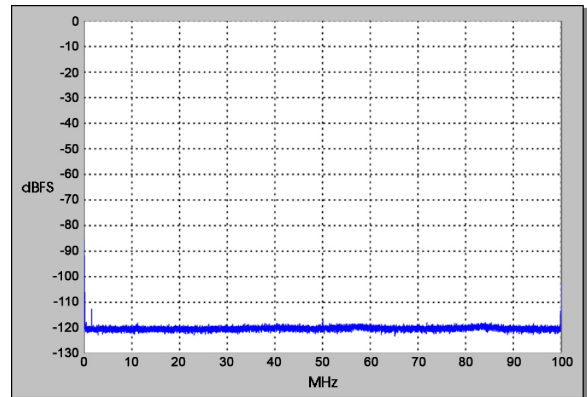

$f_s = 200 \text{ MHz}$ , Internal Clock

Two-Tone SFDR

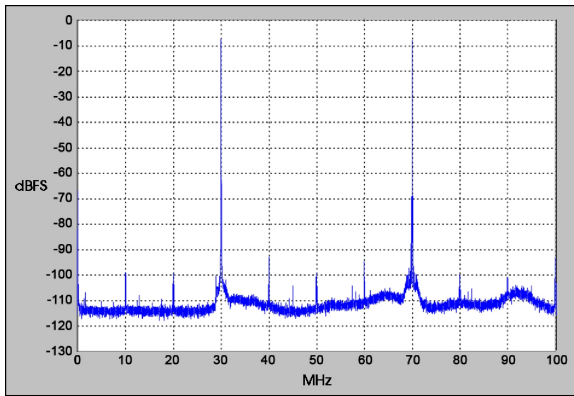

$f_1 = 30 \text{ MHz}$ ,  $f_2 = 70 \text{ MHz}$ ,  $f_s = 200 \text{ MHz}$

Two-Tone SFDR

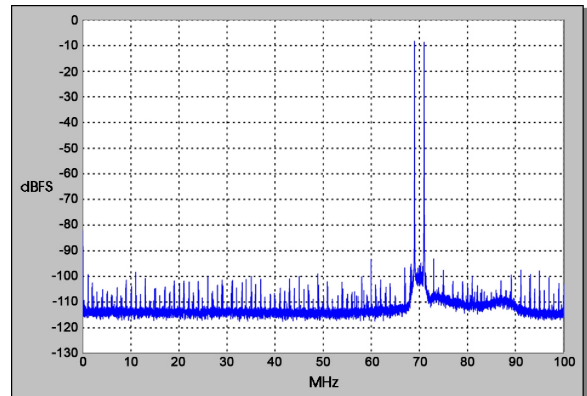

$f_1 = 69 \text{ MHz}$ ,  $f_2 = 71 \text{ MHz}$ ,  $f_s = 200 \text{ MHz}$

Adjacent Channel Crosstalk

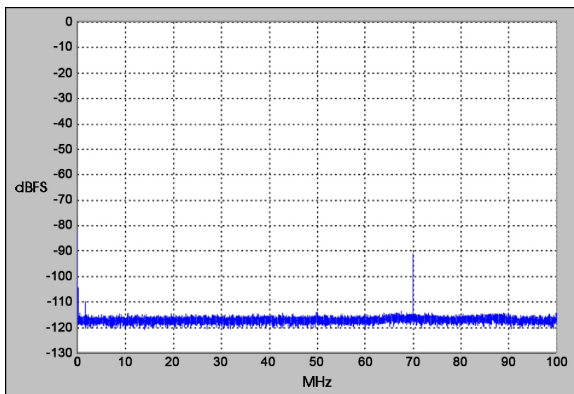

$f_{in} \text{ Ch2} = 70 \text{ MHz}$ ,  $f_s = 200 \text{ MHz}$ , Ch 1 shown

Input Frequency Response

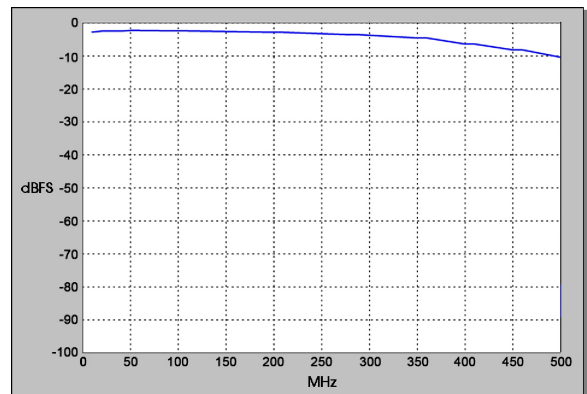

$f_s = 200 \text{ MHz}$ , Internal Clock

**FRONT PANEL CONNECTIONS**

The XMC front panel includes six SSMC coaxial connectors, and a 26-pin  $\mu$ Sync Bus connector for input/output of timing and analog signals. The front panel also includes ten LEDs.

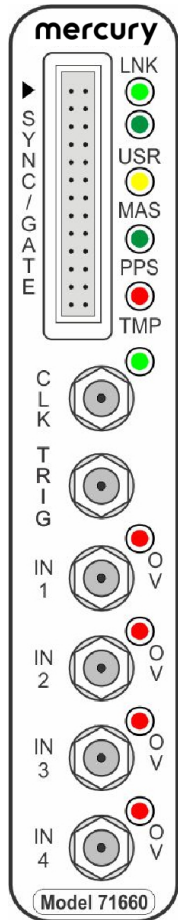

- **Sync Bus Connector:** The 26-pin Sync Bus front panel connector labeled **SYNC/GATE** provides clock, sync and gate input/output pins for the Low-Voltage Positive Emitter-Coupled Logic (LVPECL) Sync Bus. When the board is a bus master, these pins output LVPECL Sync Bus signals to other slave units. When the board is a bus Slave, these pins input LVPECL signals from a bus Master.
- **Link LED:** The green **LNK** LED

illuminates when a valid link has been established over the PCIe interface.

- **USR LED:** The green **USR** LED is for user applications.
- **Master LED:** the yellow **MAS** LED illuminates when this board is the Sync Gus Master. When only a single board is used, it must be a Master.
- **PPS LED:** the green **PPS** LED illuminates when a valid

PPS sign is detected. The LED will blink at the rate of the PPS signal.

- **Over Temperature LED:** The red **TMP** LED illuminates when an over-temperature or over-voltage condition is indicated by any of the temperature/voltage sensors on the PCB.
- **Clock LED:** The green **CLK** LED illuminates when a valid sample clock signal is detected. If the LED is not illuminated, no clock has been detected and no data from the input stream can be processed.
- **Clock Input Connector:** One SSMC coaxial connector, labeled **CLK** for the input of an external sample clock.
- **Trigger Input Connector:** The front panel has one SSMC coaxial connector, labeled **TRIG**, for input of an external trigger.
- **Analog Input Connectors:** Four SSMC coaxial connector, labeled **IN 1**, **IN 2**, **IN 3**, and **IN 4** for analog signal inputs , one for each ADC input channel.
- **ADC Overload LEDs:** There are four red **OV** LEDs, one for each A/D input. Use the applicable ADC Date Control Register to select the signal source for each OV LED, either an overload detection in the associated ADS5485, or an ADC FIFO overrun.

**SPECIFICATIONS**

**Front Panel Analog Signal Inputs**

Input Type: Transformer-coupled, front panel female SSMC connectors

Transformer Type: Coil Craft WBC4-6TLB

Full Scale Input: +8 dBm into 50 ohms

3 dB Passband: 300 kHz to 700 MHz

**A/D Converters**

Type: Texas Instruments ADS5485  
 Sampling Rate: 10 MHz to 200 MHz  
 Resolution: 16 bits

**Digital Downconverters**

Quantity: Four channels  
 Decimation Range: 2x to 65,536x in two stages of 2x to 256x  
 LO Tuning Freq. Resolution: 32 bits, 0 to  $f_s$   
 LO SFDR: >120 dB  
 Phase Offset Resolution: 32 bits, 0 to 360 degrees  
 FIR Filter: 18-bit coefficients, 24-bit output, user programmable coefficients  
 Default Filter Set: 80% bandwidth, <0.3 dB passband ripple, >100 dB stopband attenuation

**Beamformer**

Summation: Four channels on-board; multiple boards can be summed via Summation Expansion Chain  
 Summation Expansion Chain: One chain in and one chain out link via XMC connector using Aurora protocol  
 Phase Shift Coefficients: I & Q with 16-bit resolution  
 Gain Coefficients: 16-bit resolution  
 Channel Summation: 24-bit  
 Multiboard Summation Expansion: 32-bit

**Sample Clock Sources**

On-board clock synthesizer

**Clock Synthesizer**

Clock Source: Selectable from on-board programmable VCXO (10 to 810 MHz), front panel external clock or LVPECL timing bus

Synchronization: VCXO can be locked to an external 4 to 180 MHz PLL system reference, typically 10 MHz

Clock Dividers: External clock or VCXO can be divided by 1, 2, 4, 8, or 16 for the A/D clock



**External Clock**

Type: Front panel female SSMC connector, sine wave, 0 to +10 dBm, AC-coupled, 50 ohms, accepts 10 to 800 MHz sample clock or PLL system reference

**Timing Bus**

26-pin connector LVPECL bus includes, clock/sync/gate/PPS inputs and outputs; TTL signal for gate/ trigger and sync/PPS inputs

**External Trigger Input**

Type: Front panel female SSMC connector, LVTTTL  
 Function: Programmable functions include: trigger, gate, sync and PPS

**Field Programmable Gate Array**

Standard: Xilinx Virtex-6 XC6VLX240T  
 Optional: Xilinx Virtex-6 XC6VVSX315T

**Custom I/O**

Option -104: Installs the PMC P14 connector with 20 LVDS pairs to the FPGA

**Memory**

Option 150 or 160: Two 8 MB QDRII+ SRAM memory banks, 400 MHz DDR  
 Option 155 or 165: Two 512 MB DDR3 SDRAM memory banks, 400 MHz DDR

**PCI Express Interface**

PCI Express Bus: Gen. 1: x4 or x8;  
 Gen. 2: x4

**Environmental**

Standard: L0 (air-cooled)

- Operating Temp: 0° to 50° C
- Storage Temp: -20° to 90° C
- Relative Humidity: 0 to 95%, non-condensing

Option -702: L2 (air-cooled)

- Operating Temp: -20° to 65° C
- Storage Temp: -40° to 100° C
- Relative Humidity: 0 to 95%, non-condensing

Option -713: L3 (conduction-cooled)

- Operating Temp: -40° to 70° C
- Storage Temp: -50° to 100° C
- Relative Humidity: 0 to 95%, non-condensing

**Physical**

Dimensions: Standard XMC module

- Depth: 149.0 mm (5.87 in.)
- Height: 74 mm (2.91 in.)

Weight: Approximately 14 oz. (400 grams)

**ORDERING INFORMATION**

Model	Description
71661	4-Channel 200 MHz A/D with DDCs and Virtex-6 FPGA - XMC

Options	Description
-062	XC6VLX240T FPGA
-064	XC6VVSX315T FPGA
-104	LVDS FPGA I/O through P14 connector
-150	Two 8 MB QDRII+ SRAM Memory Banks (Banks 1 and 2)
-155	Two 512 MB DDR3 SDRAM Memory Banks (Banks 1 and 2)
-160	Two 8 MB QDRII+ SRAM Memory Banks (Banks 3 and 4)
-165	Two 512 MB DDR3 SDRAM Memory Banks (Banks 3 and 4)
-702	Air-cooled, Level 2
-713	Conduction-cooled, Level 3
-730	2-slot heat sink
Contact Mercury for compatible option combinations.	

**ACCESSORY PRODUCTS**

Model	Description
2171	Cable Kit: SSMC to SMA

**DEVELOPMENT SYSTEMS**

Mercury offers development systems for Cobalt products. They come with all pre-tested software and hardware ready for immediate operation. These systems are intended to save engineers and system integrators the time and expense associated with building and testing a development system that ensures optimum performance of Cobalt boards. Please [contact Mercury](#) to configure a system that matches your requirements.

**FORM FACTORS**

Cobalt products are available in standard form factors including 3U VPX, 6U VPX, PCIe, and XMC. The Cobalt Model 71661 XMC (4-Channel 200 MHz A/D with DDC, Virtex-6 FPGA) has the following variants:

Model	
52661	3U VPX board (single XMC)
54661	3U VPX board (single XMC with optical/backplane RF))
57661	6U VPX board (single XMC)
58661	6U VPX board (dual XMC)
71661	XMC module
78661	PCIe board (single XMC)

**LIFETIME SUPPORT FOR COBALT PRODUCTS**

Mercury offers worldwide customers shorter development time, reliable, rugged solutions for a variety of environments, reduced costs, and mature software development tools. We offer free lifetime support from our engineering staff, which customers can depend on through phone and email, as well as software updates. Take advantage of our 40 years of experience in delivering high-performance radar, communications, SIGINT, EW, and data acquisition MIL-Aero solutions worldwide.



**Corporate Headquarters**

50 Minuteman Road  
 Andover, MA 01810 USA  
**+1 978.967.1401** tel  
**+1 866.627.6951** tel  
**+1 978.256.3599** fax

**International Headquarters**

**Mercury International**  
 Avenue Eugène-Lance, 38  
 PO Box 584  
 CH-1212 Grand-Lancy 1  
 Geneva, Switzerland  
**+41 22 884 5100** tel

**Learn more**

**Visit:** [mrcy.com/go/MP71661](http://mrcy.com/go/MP71661)

**For technical details, contact:**  
[mrcy.com/go/CF71661](http://mrcy.com/go/CF71661)



The Mercury Systems logo and the following are trademarks or registered trademarks of Mercury Systems, Inc.: Mercury Systems, Innovation That Matters, Cobalt, ReadyFlow, and GateFlow. Other marks used herein may be trademarks or registered trademarks of their respective holders. Mercury believes this information is accurate as of its publication date and is not responsible for any inadvertent errors. The information contained herein is subject to change without notice.

