

# AM3163 – Filter Bank

## Digitally Tunable 2 to 18 GHz Bandpass

### Description

AM3163 is a digitally tunable bandpass filter bank covering the 2 GHz to 18 GHz frequency range. The device provides three separate tunable filter bands with 16 low-pass and 16 high-pass tuning states for independent control of both the center frequency and bandwidth. The filter bank has integrated switches with a 20 GHz bypass path. AM3163 is packaged in a 6mm QFN package and operates over the -40C to +85C temperature range. Its small size, weight, and power consumption make it an attractive choice for demanding applications requiring low SWaP components.

### Features

- 2 to 18 GHz Digitally Tunable Bandpass Filter Bank
- Internal SP4T Switches
- Integrated Control Line Filtering
- Independent LP and HP control
- +3.3V to +5.0V Supply
- 8 dB typical Insertion Loss
- 20 GHz Filter Bypass Path
- +39 dBm Input IP3
- +26 dBm Input P1dB
- -40C to +85C Operation
- 6mm QFN

### Functional Diagram

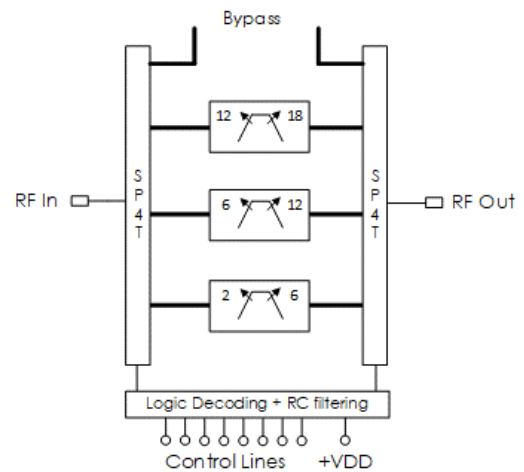

### Characteristic Performance

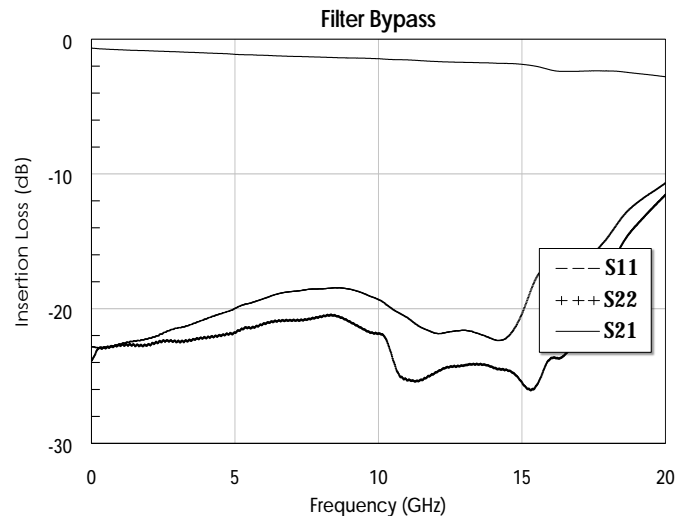
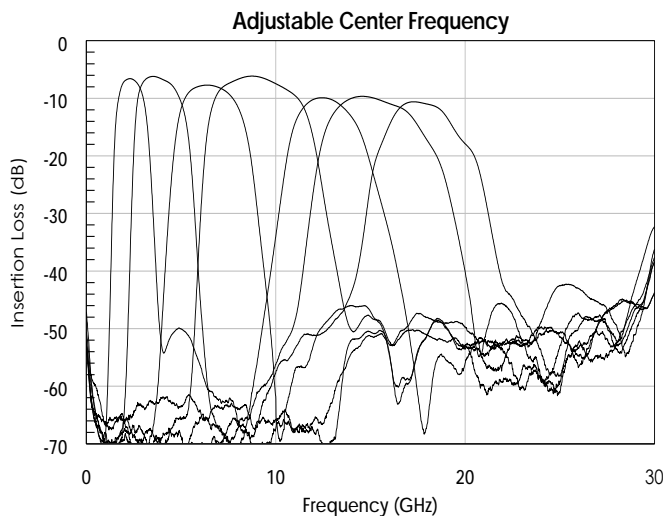

### Table of Contents

Description .....	1	DC Electrical Characteristics.....	5
Features.....	1	RF Performance .....	5
Functional Diagram.....	1	Timing Characteristics .....	5
Characteristic Performance .....	1	State Table .....	6
Revision History .....	2	Typical Performance .....	7
Pin Layout and Definitions.....	3	Typical Application.....	10
Specifications .....	4	Evaluation PC Board .....	11
Absolute Maximum Ratings.....	4	Related Parts.....	11
Handling Information.....	4	Component Compliance Information.....	12
Recommended Operating Conditions....	4		

### Revision History

Date	Revision Number	Notes
August 26, 2020	1	Initial Release
May 4, 2021	2	Updated diagrams

# AM3163 – Filter Bank



## Digitally Tunable 2 to 18 GHz Bandpass

### Pin Layout and Definitions

Note: All Non-Assigned Pins are GND

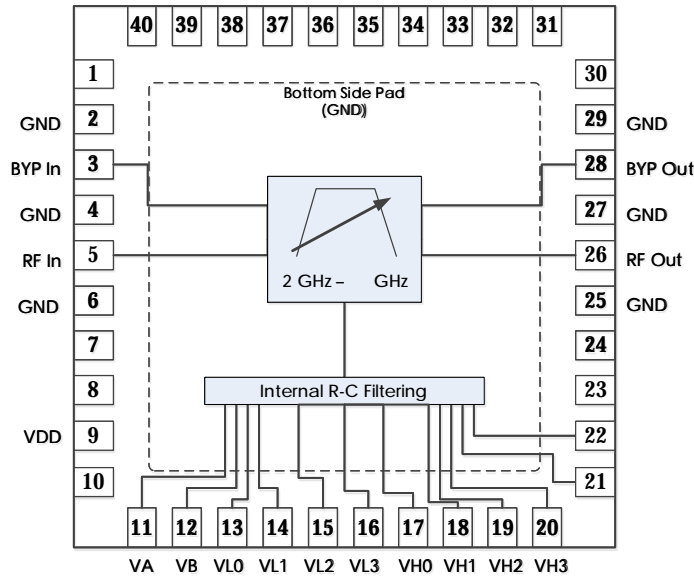

Pin Number	Pin Name	Pin Function
1-2	GND	Ground – Common
3	BYP In	Filter Bypass Input Side – 50 Ohms – DC Coupled, External DC Blocking Cap Required
4	GND	Ground – Common
5	RF In	RF Input – 50 Ohms – DC Coupled, External DC Blocking Cap Required
6-8	GND	Ground – Common
9	VDD	DC Power Input
10	GND	Ground – Common
11	VA	Switch Control A
12	VB	Switch Control B
13	VL0	Low Pass Filter Control Bit 0 (LSB)
14	VL1	Low Pass Filter Control Bit 1
15	VL2	Low Pass Filter Control Bit 2
16	VL3	High Pass Filter Control Bit 3 (MSB)
17	VH0	High Pass Filter Control Bit 0 (LSB)
18	VH1	High Pass Filter Control Bit 1
19	VH2	High Pass Filter Control Bit 2
20	VH3	High Pass Filter Control Bit 3 (MSB)
21-25	GND	Ground – Common
26	RF Out	RF Output – 50 Ohms – DC Coupled, External DC Blocking Cap Required
27	GND	Ground – Common
28	BYP Out	Filter Bypass Output Side – 50 Ohms – DC Coupled, External DC Blocking Cap Required
29-30	GND	Ground – Common
Bottom Pad	GND	Ground – Common

To obtain price, delivery, or to place an order contact [MMICSales@mercy.com](mailto:MMICSales@mercy.com)  
 Atlanta Micro Inc., 3720 Davinci Ct, Suite 125, Peachtree Corners, GA 30092 • Phone: (470) 253-7640 • [www.atlantamicro.com](http://www.atlantamicro.com)

# AM3163 – Filter Bank



Digitally Tunable 2 to 18 GHz Bandpass

## Specifications

### Absolute Maximum Ratings

	Minimum	Maximum
Supply Voltage	-0.3 V	+8.0 V
RF Input Power		+27 dBm
Operating Junction Temperature	-40 C	+150 C
Storage Temperature Range	-50 C	+150 C

**Note:** Any device operation beyond the Absolute Maximum Ratings may result in permanent damage to the device. The values listed in this table are extremes and do not imply functional operation of the device at these or any other conditions beyond what is listed under Recommended Operating Conditions. Any part subjected to conditions outside of what is recommended for an extended amount of time may suffer from reliability concerns.

### Handling Information

	Minimum	Maximum
Storage Temperature Range (Recommended)	-50 C	+125 C
Moisture Sensitivity Level	MSL 1	



Atlanta Micro products are electrostatic sensitive.  
Follow safe handling practices to avoid damage

### Recommended Operating Conditions

	Minimum	Typical	Maximum
Supply Voltage	+3.0 V	+5.0 V	+5.2 V
Operating Case Temperature	-40 C		+85 C
Operating Junction Temperature	-40 C		+125 C

# AM3163 – Filter Bank

## Digitally Tunable 2 to 18 GHz Bandpass

### DC Electrical Characteristics

(T = 25 °C unless otherwise specified)

Parameter	Testing Conditions	Minimum	Typical	Maximum
DC Supply Voltage		+3.0 V	+5.0 V	+5.2 V
DC Supply Current	VDD = +5.0 V		6 mA	
Power Dissipated	VDD = +5.0 V		30 mW	
Logic Level Low		-0.1 V		+0.5 V
Logic Level High		+2.0 V		+VDD V

### RF Performance

(T = 25 °C unless otherwise specified)

Parameter	Testing Conditions	Minimum	Typical	Maximum
Frequency Range		2 GHz		18 GHz
Insertion Loss	f = 2 GHz		-7.1 dB	
	f = 4 GHz		-6.3 dB	
	f = 6 GHz		-7.7 dB	
	f = 9 GHz		-6.2 dB	
	f = 12 GHz		-7.2 dB	
	f = 15 GHz		-9.8 dB	
	f = 18 GHz		-11 dB	
Return Loss			-12 dB	
Input IP3	VDD = +5.0 V		+39 dBm	
Input P1dB	VDD = +5.0 V		+26 dBm	

### Timing Characteristics

Parameter	Minimum	Typical	Maximum
Switching Speed		40 ns	
Band Tuning Speed		400 ns	

### State Table

VA	VB	Filter Band
Low	Low	Bypass State
High	High	Band 1 – 2.0 to 6.0 GHz
Low	High	Band 2 – 6.0 to 12 GHz
High	Low	Band 3 – 12 to 18 GHz

### Notes:

1. OIP3 was measured at 10 MHz input tone spacing

# AM3163 – Filter Bank

## Digitally Tunable 2 to 18 GHz Bandpass

### State Table (continued)

#### High Pass Filter Typical Cutoff Frequencies (GHz)

VH3	VH2	VH1	VH0	Band 1	Band 2	Band 3
Low	Low	Low	Low	1.7	5.1	11
Low	Low	Low	High	1.8	5.2	11.1
Low	Low	High	Low	1.85	5.3	11.2
Low	Low	High	High	1.9	5.3	11.4
Low	High	Low	Low	1.92	5.4	11.4
Low	High	Low	High	1.96	5.5	11.5
Low	High	High	Low	2	5.7	11.7
Low	High	High	High	2.1	5.9	12
High	Low	Low	Low	2.4	5.8	11.8
High	Low	Low	High	2.44	6	12
High	Low	High	Low	2.5	6.3	12.3
High	Low	High	High	2.6	6.5	12.7
High	High	Low	Low	2.8	6.8	12.8
High	High	Low	High	3	7.3	13.4
High	High	High	Low	3.3	8.1	14.2
High	High	High	High	3.9	9.1	15.8

#### Low Pass Filter Typical Cutoff Frequencies (GHz)

VL3	VL2	VL1	VL0	Band 1	Band 2	Band 3
Low	Low	Low	Low	2.9	7.8	13.8
Low	Low	Low	High	3	8	13.9
Low	Low	High	Low	3.1	8.1	14.1
Low	Low	High	High	3.2	8.3	14.4
Low	High	Low	Low	3.3	8.6	14.5
Low	High	Low	High	3.4	8.8	14.9
Low	High	High	Low	3.5	9	15.2
Low	High	High	High	3.7	9.1	15.4
High	Low	Low	Low	3.9	9.2	15.7
High	Low	Low	High	4.1	9.5	16
High	Low	High	Low	4.3	9.8	16.2
High	Low	High	High	4.5	10.1	16.6
High	High	Low	Low	4.8	10.6	16.7
High	High	Low	High	5.1	11	17.2
High	High	High	Low	5.6	11.6	18
High	High	High	High	6.3	12.3	19.6

# AM3163 – Filter Bank

## Digitally Tunable 2 to 18 GHz Bandpass



### Typical Performance

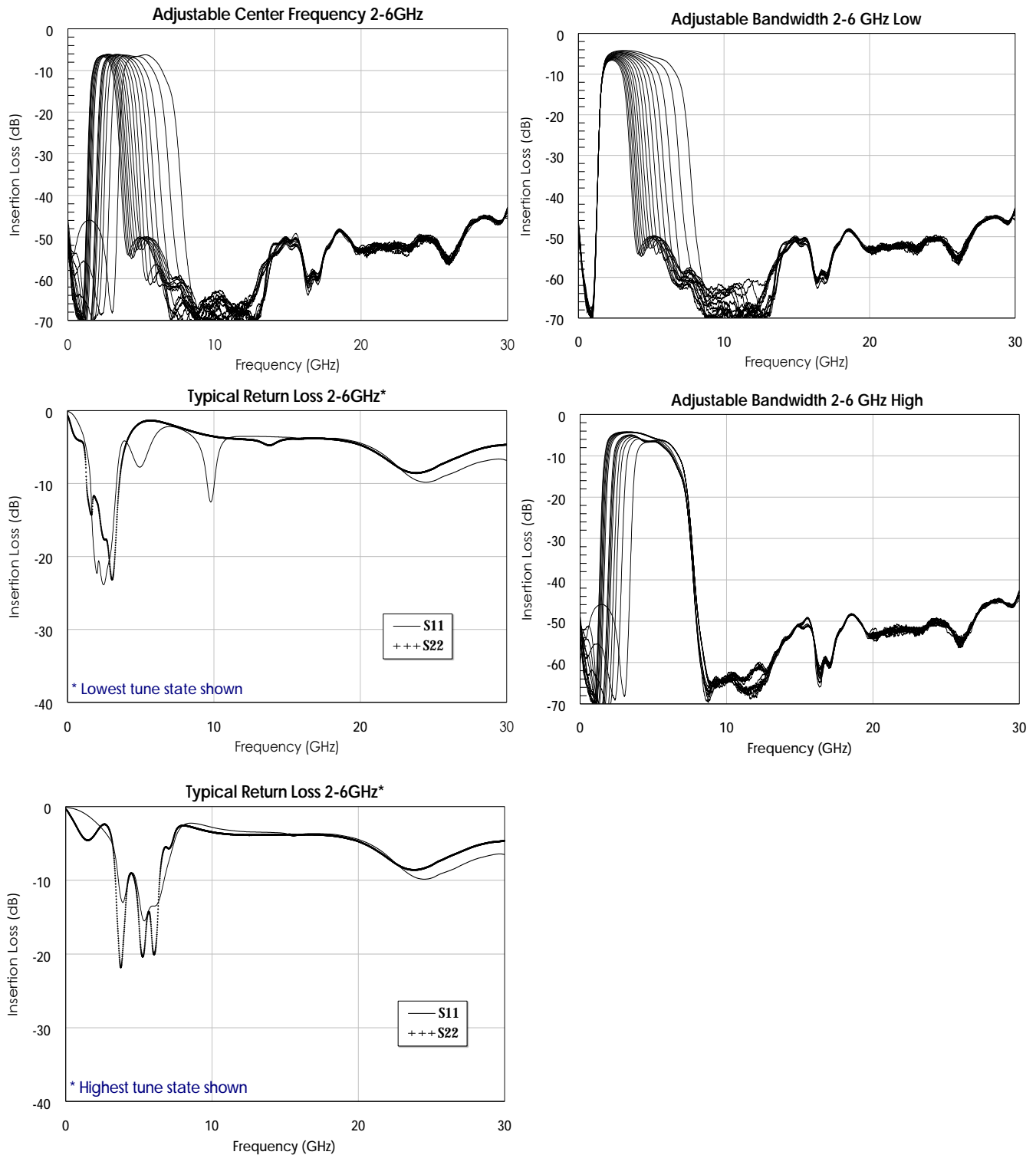

\* Typical values shown for lowest tuned frequency (control bits 0000) or highest tuned frequency (control bits 1111)

# AM3163 – Filter Bank

## Digitally Tunable 2 to 18 GHz Bandpass



### Typical Performance (continued)

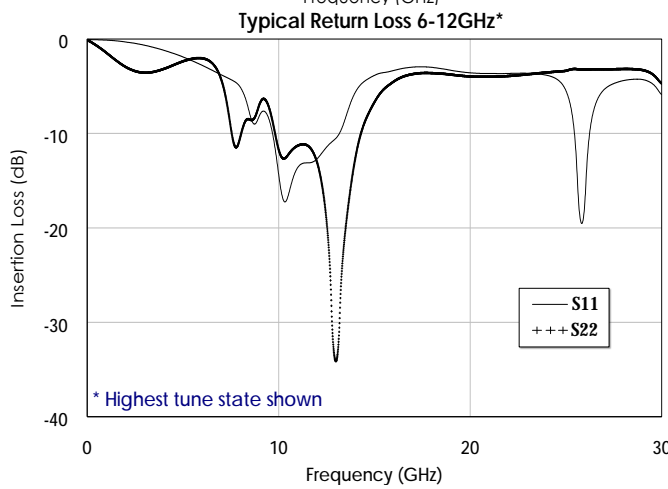
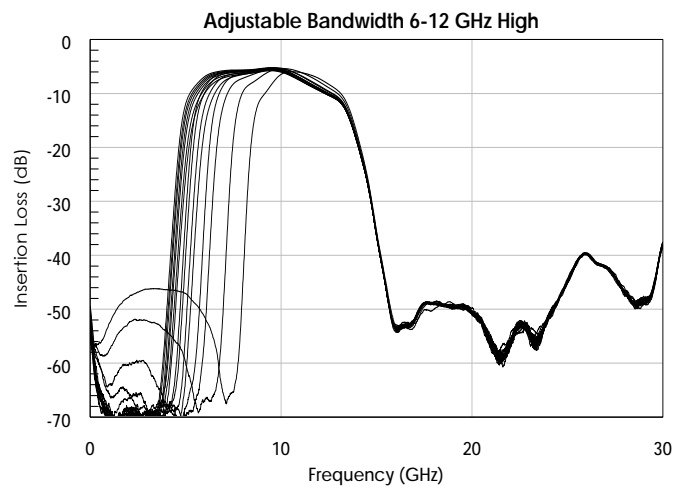
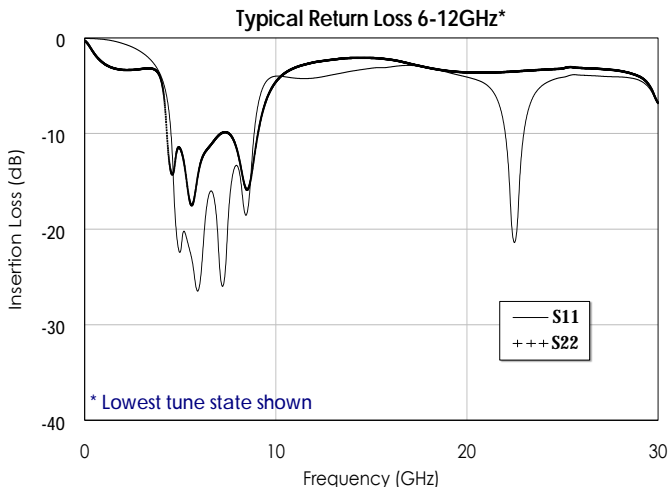
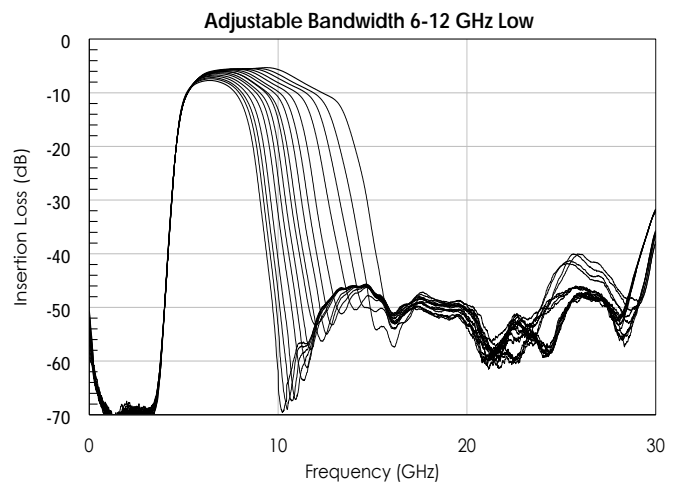
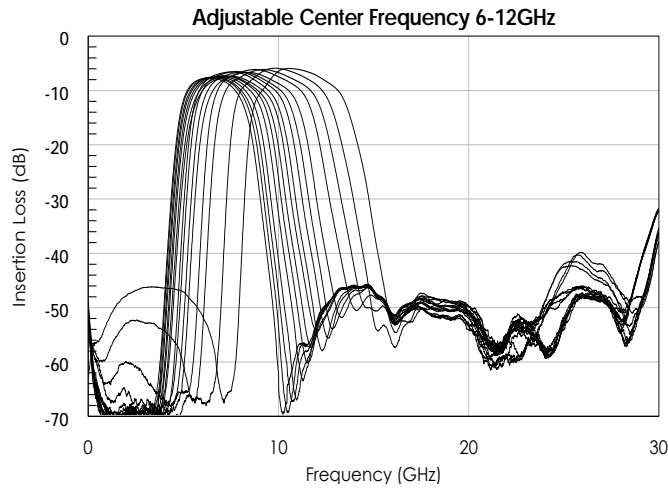

\* Typical values shown for lowest tuned frequency (control bits 0000) or highest tuned frequency (control bits 1111)



# AM3163 – Filter Bank

## Digitally Tunable 2 to 18 GHz Bandpass

### Typical Performance (continued)

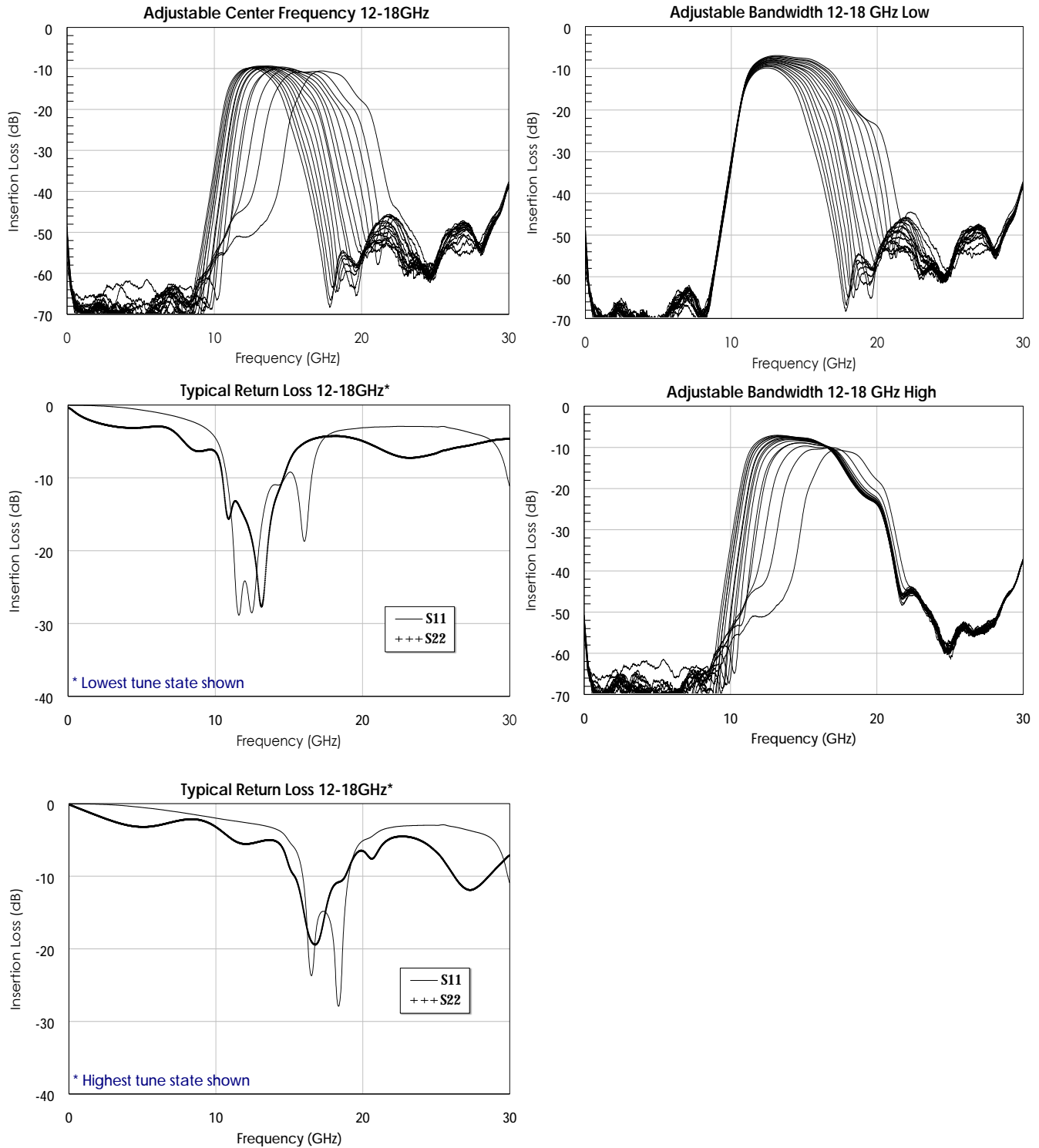

\* Typical values shown for lowest tuned frequency (control bits 0000) or highest tuned frequency (control bits 1111)

# AM3163 – Filter Bank

## Digitally Tunable 2 to 18 GHz Bandpass



### Typical Application

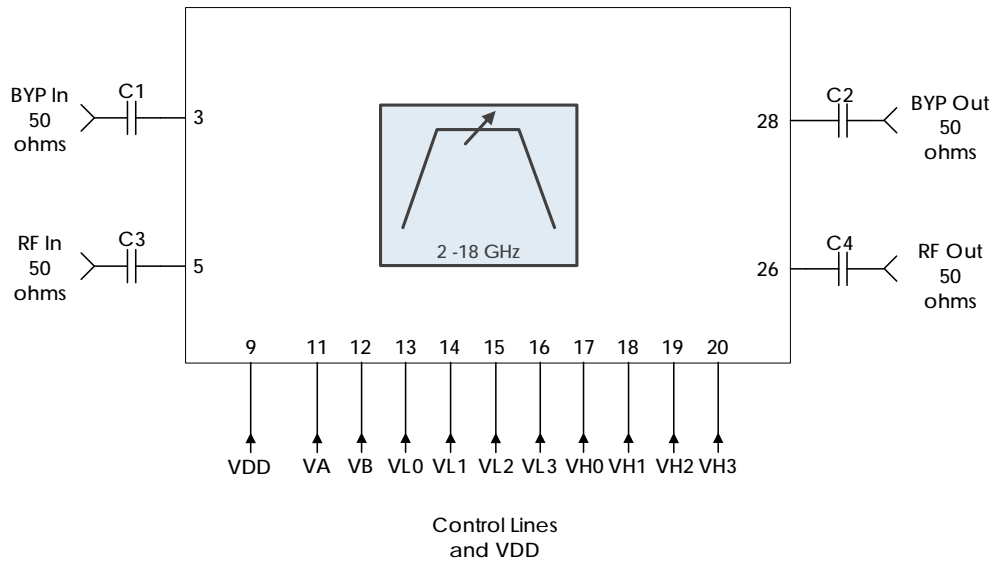

### Recommended Component List (or equivalent):

Part	Value	Part Number	Manufacturer
C1-C4	0. $\mu$ F	0201BB104KW160	Passives Plus

### Notes:

1. DC blocking capacitors should be high performance, low-loss, broadband capacitors for optimum performance.
2. VDD and control lines filtered internally providing high frequency isolation.

# AM3163 – Filter Bank

## Digitally Tunable 2 to 18 GHz Bandpass



### Evaluation PC Board

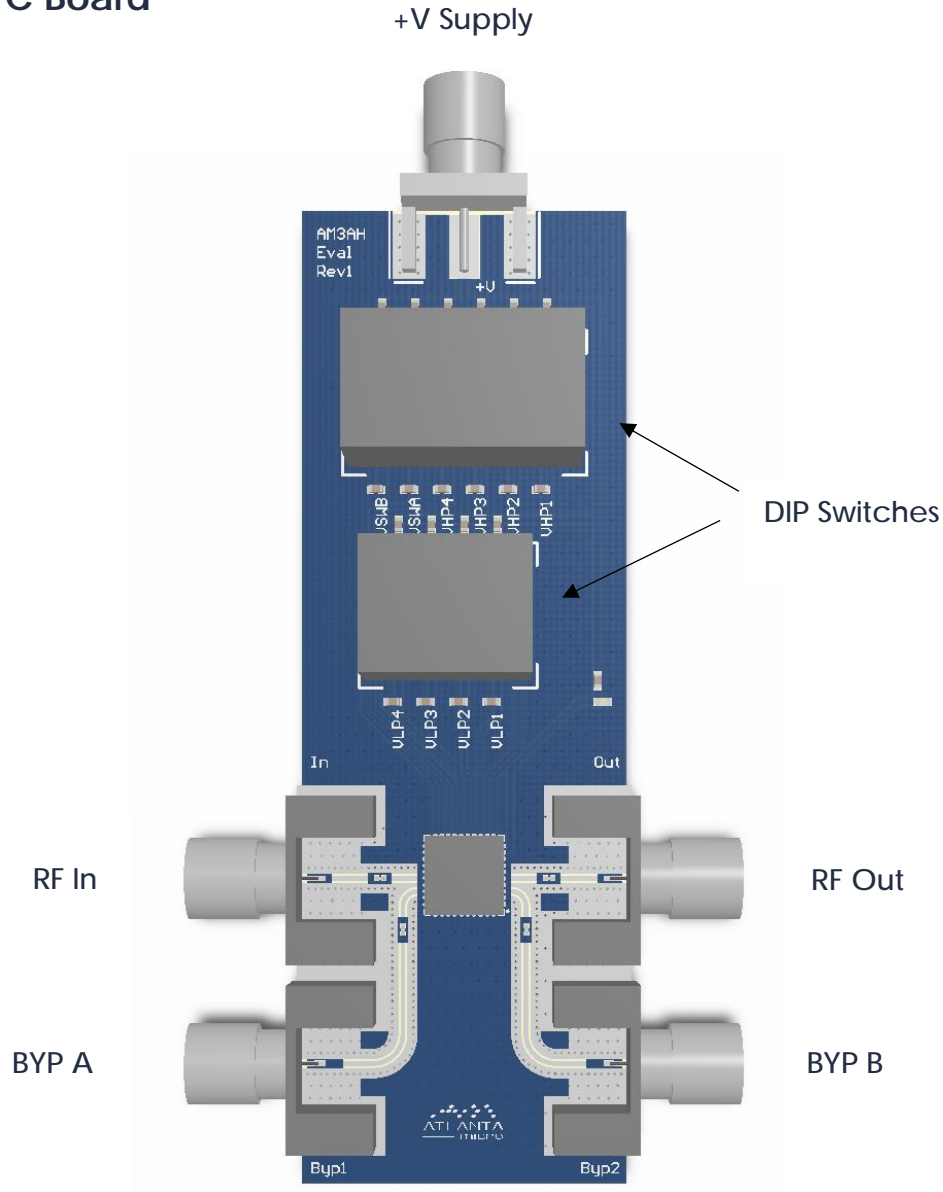

### Related Parts

Part Number	Description
AM3152	0.4 GHz to 8 GHz Digitally Tunable Bandpass Filter
AM3066	12 GHz to 26.5 GHz Digitally Tunable Bandpass Filter

To obtain price, delivery, or to place an order contact [MMICSales@rcy.com](mailto:MMICSales@rcy.com)  
 Atlanta Micro Inc., 3720 Davinci Ct, Suite 125, Peachtree Corners, GA 30092 • Phone: (470) 253-7640 • [www.atlantamicro.com](http://www.atlantamicro.com)

### Component Compliance Information

**RoHS:** Atlanta Micro, Inc. hereby certifies that all products comply with the EC Directive 2011/65/EC on the Restriction of Hazardous Substances, commonly known as EU-RoHS 6 and 10. All products supplied by Atlanta Micro shall be compliant with the European Directive 2011/65/EC based on the following substance list.

Substance List	Allowable Maximum Concentration
Lead (Pb)	<1000 PPM (0.1% by weight)
Mercury (Hg)	<1000 PPM (0.1% by weight)
Cadmium (Cd)	<75 PPM (0.0075% by weight)
Hexavalent Chromium (CrVI)	<1000 PPM (0.1% by weight)
Polybrominated Biphenyls (PBB)	<1000 PPM (0.1% by weight)
Polybrominated Diphenyl ethers (PBDE)	<1000 PPM (0.1% by weight)
Decabromodiphenyl Deca BDE	<1000 PPM (0.1% by weight)
Bis (2-ethylhexyl) Phthalate (DEHP)	<1000 PPM (0.1% by weight)
Butyl Benzyl Phthalate (BBP)	<1000 PPM (0.1% by weight)
Dibutyl Phthalate (DBP)	<1000 PPM (0.1% by weight)
Diisobutyl Phthalate (DIBP)	<1000 PPM (0.1% by weight)

**REACH:** Atlanta Micro, Inc. neither uses nor intentionally adds any of the substances considered to be a Substance of Very High Concern (SVHC) as defined by the EU Regulation (EC) No. 1907-2006 on Registration, Evaluation, Authorization, and Restriction of Chemicals (REACH).

**Conflict Materials:** Atlanta Micro does not knowingly use materials that are sourced from the Democratic Republic of Congo (DRC) or any other known conflict regions. Atlanta Micro’s supply chain is comprised of sources that are both environmentally and socially responsible. We periodically review this requirement with our vendors to ensure continued compliance.

Atlanta Micro takes its responsibility as a global partner seriously and will use due diligence within our supply chain to ensure all standards are met to the best of our knowledge.