

AM3035 – Tunable Filter

Digitally Tunable 500 to 1200 MHz Lowpass

Description

AM3035 is a miniature digitally tunable lowpass filter covering the 500 MHz to 1200 MHz frequency range. The filter provides 16 selectable lowpass cutoff states with 4 digital control bits. The tunable lowpass filter can be combined with one of Atlanta Micro’s tunable highpass filters to provide a flexible tunable bandpass filter solution. AM3035 is packaged in a 4mm QFN package and operates over the -40C to +100C temperature range.

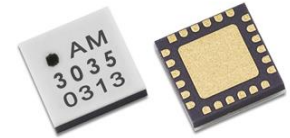

Features

- Discrete low pass cutoff steps
- 4-bit control, 3V or 5V logic
- No calibration required
- 5V DC supply
- 4mm QFN package
- -40C to +100C operation

Functional Diagram

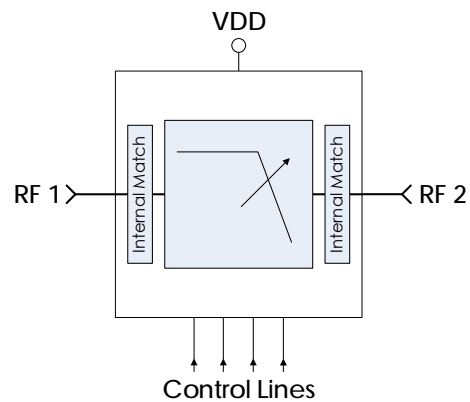

Characteristic Performance

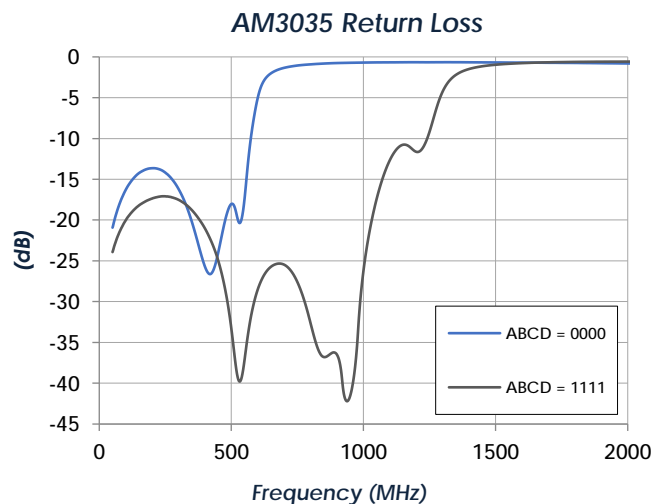
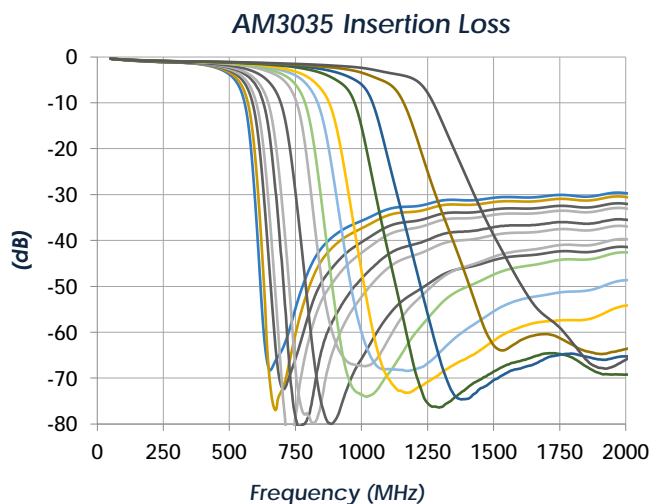

Table of Contents

Description	1	RF Performance	5
Features	1	Timing Characteristics	5
Functional Diagram	1	State Table	6
Characteristic Performance	1	Typical Performance	7
Revision History	2	Typical Application	8
Pin Layout and Definitions	3	Multiple Passives	8
Specifications	4	Smallest Footprint	9
Absolute Maximum Ratings	4	Evaluation PC Board	10
Handling Information	4	Related Parts	10
Recommended Operating Conditions	4	Component Compliance Information	11
DC Electrical Characteristics	5		

Revision History

Date	Revision Number	Notes
May 16, 2016	1	Initial Release
May 16, 2016	2	Updated NC pin recommendation
May 20, 2016	3	Updated recommended components
January 20, 2017	4	Updated business address
February 16, 2017	5	Added recommended footprint
June 7, 2021	6	Extended operating temperature to +100C, added group delay plots, moved package information to separate document, updated datasheet format

AM3035 – Tunable Filter

Digitally Tunable 500 to 1200 MHz Lowpass

Pin Layout and Definitions

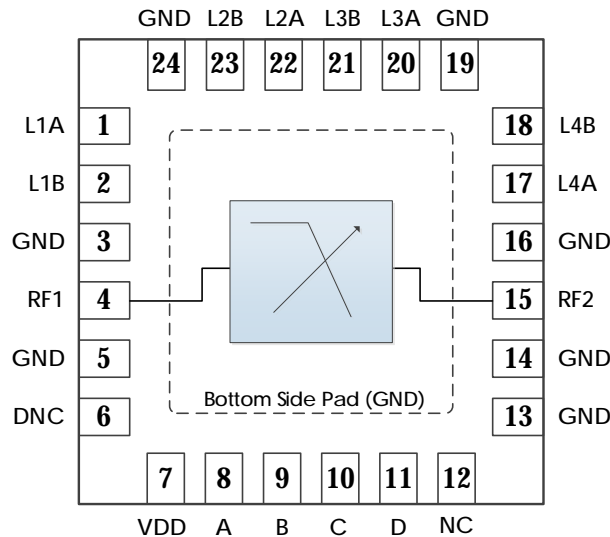

Pin Number	Pin Name	Pin Function
1	L1A	External Inductor L1 Connection
2	L1B	External Inductor L1 Connection
3	GND	Ground – Common
4	RF 1	RF Port 1 – 50 ohms, DC coupled. External AC coupling capacitor required.
5	GND	Ground – Common
6	DNC	Do Not Connect
7	Vcc	+5.0V DC Power Input
8	A	Filter Control Bit A
9	B	Filter Control Bit B
10	C	Filter Control Bit C
11	D	Filter Control Bit D
12	NC	Not Connected. Pin may be grounded or left floating.
13 – 14	GND	Ground – Common
15	RF 2	RF Port 2 – 50 ohms, DC coupled. External AC coupling capacitor required.
16	GND	Ground – Common
17	L4A	External Inductor L4 Connection
18	L4B	External Inductor L4 Connection
19	GND	Ground – Common
20	L3A	External Inductor L3 Connection
21	L3B	External Inductor L3 Connection
22	L2A	External Inductor L2 Connection
23	L2B	External Inductor L2 Connection
24	GND	Ground – Common

To obtain price, delivery, or to place an order contact MMICSales@rcry.com
 Atlanta Micro Inc., 3720 Davinci Ct, Suite 400, Peachtree Corners, GA 30092 • Phone: (470) 253-7640 • www.atlantamicro.com

AM3035 – Tunable Filter

Digitally Tunable 500 to 1200 MHz Lowpass

Specifications

Absolute Maximum Ratings

	Minimum	Maximum
Supply Voltage	-0.3 V	+6.0 V
RF Input Power		+27 dBm
Operating Junction Temperature	-40 C	+150 C
Storage Temperature Range	-55 C	+150 C

Note: Any device operation beyond the Absolute Maximum Ratings may result in permanent damage to the device. The values listed in this table are extremes and do not imply functional operation of the device at these or any other conditions beyond what is listed under Recommended Operating Conditions. Any part subjected to conditions outside of what is recommended for an extended amount of time may suffer from reliability concerns.

Handling Information

	Minimum	Maximum
Storage Temperature Range (Recommended)	-50 C	+125 C
Moisture Sensitivity Level	MSL 1	



Atlanta Micro products are electrostatic sensitive.
Follow safe handling practices to avoid damage

Recommended Operating Conditions

	Minimum	Typical	Maximum
Supply Voltage		+5.0 V	
Operating Case Temperature	-40 C		+100 C
Operating Junction Temperature	-40 C		+125 C

AM3035 – Tunable Filter

Digitally Tunable 500 to 1200 MHz Lowpass

DC Electrical Characteristics

(T = 25 °C unless otherwise specified)

Parameter	Testing Conditions	Minimum	Typical	Maximum
DC Supply Voltage		+4.7 V	+5.0 V	+5.2 V
DC Supply Current	VDD = +5.0 V		1 mA	
Power Dissipated	VDD = +5.0 V		5 mW	
Logic Level Low		-0.1 V		+0.5 V
Logic Level High		+2.0 V		+5.0 V

RF Performance

(T = 25 °C unless otherwise specified)

Parameter	Testing Conditions	Minimum	Typical	Maximum
Cutoff Frequency Range		500 MHz		1200 MHz
Insertion Loss	f = 250 MHz, ABCD = 1111		0.9 dB	
	f = 750 MHz, ABCD = 1111		1.5 dB	
	f = 1.2 GHz, ABCD = 1111		4.9 dB	
Return Loss	f = 250 MHz, ABCD = 1111		17 dB	
	f = 750 MHz, ABCD = 1111		28 dB	
	f = 1.2 GHz, ABCD = 1111		12 dB	
Input IP3	ABCD = 1111		+40 dBm	

Timing Characteristics

Parameter	Minimum	Typical	Maximum
Switching Speed			1 us

AM3035 – Tunable Filter

Digitally Tunable 500 to 1200 MHz Lowpass

State Table

D	C	B	A	Typical Cutoff Frequency (GHz)
L	L	L	L	493
L	L	L	H	503
L	L	H	L	518
L	L	H	H	530
L	H	L	L	552
L	H	L	H	567
L	H	H	L	587
L	H	H	H	604
H	L	L	L	661
H	L	L	H	690
H	L	H	L	732
H	L	H	H	767
H	H	L	L	850
H	H	L	H	915
H	H	H	L	1032
H	H	H	H	1200

AM3035 – Tunable Filter

Digitally Tunable 500 to 1200 MHz Lowpass

Typical Performance

(T = 25 °C unless otherwise specified. Only some states shown for simplicity. Refer to s-parameters available for download on Atlanta Micro website for more information)

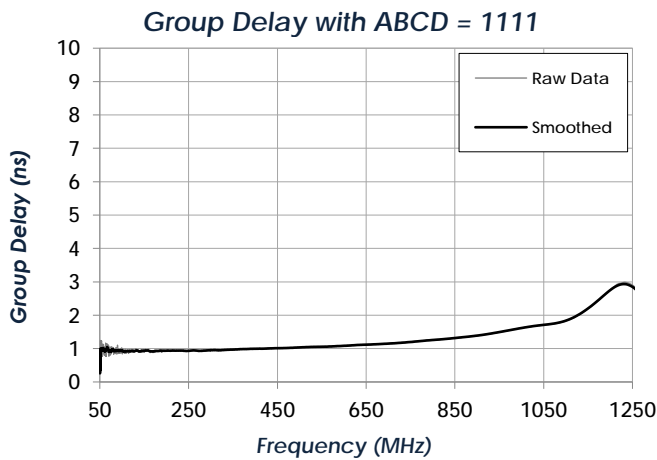
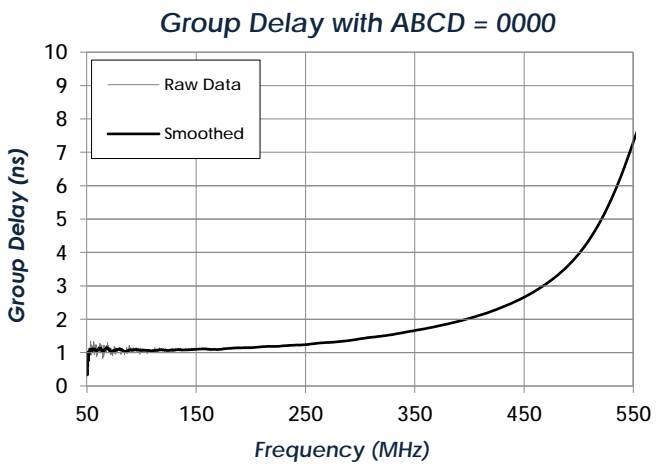
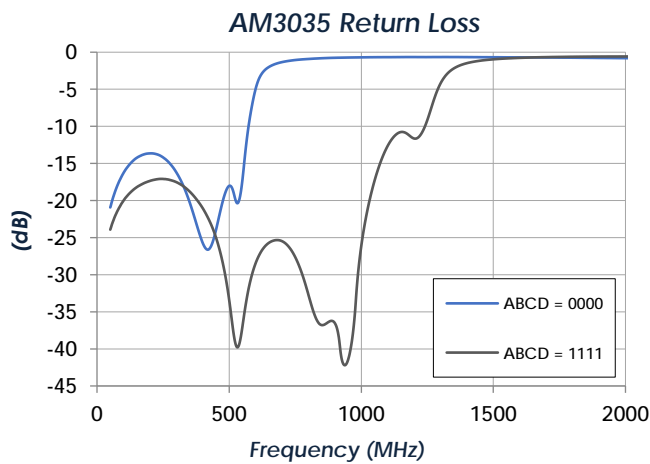
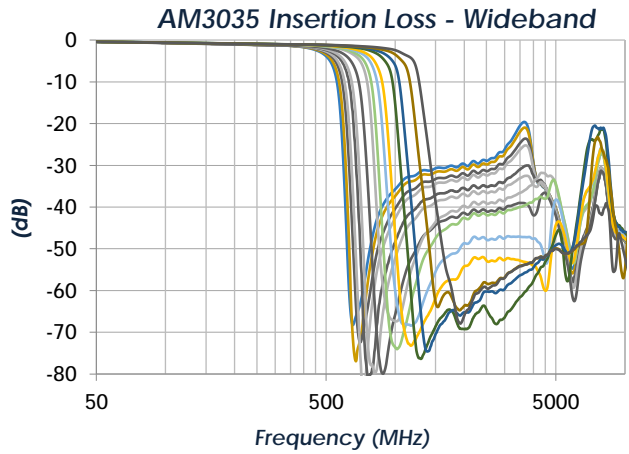
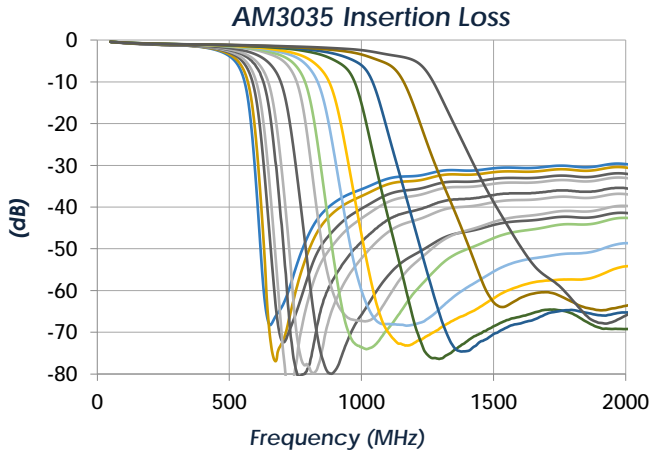

AM3035 – Tunable Filter

Digitally Tunable 500 to 1200 MHz Lowpass

Typical Application

Multiple Passives

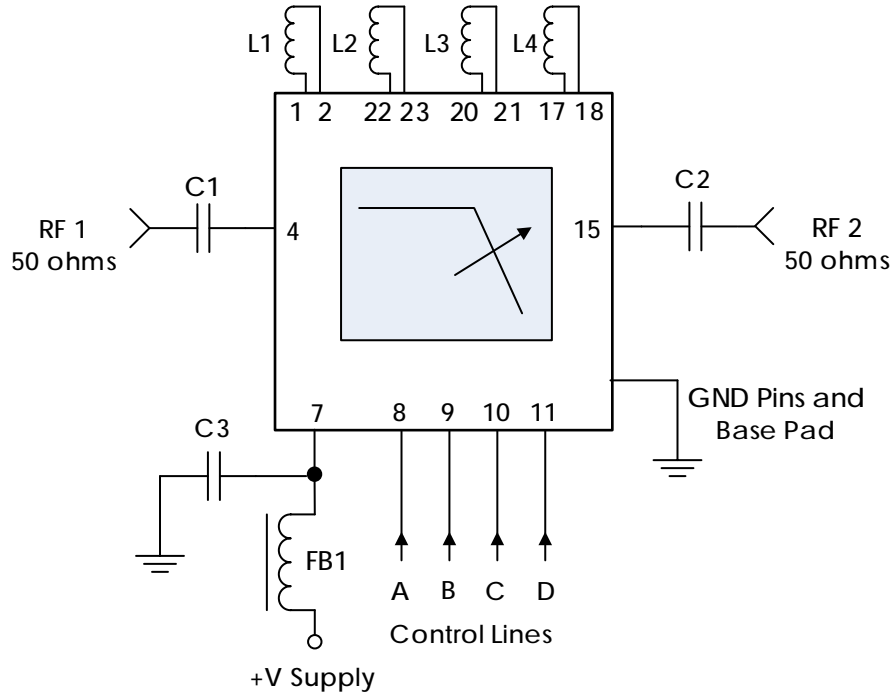

Recommended Component List (or equivalent):

Part	Value	Part Number	Manufacturer
C1, C2	0.1 μ F	0402BB104KW160	Passives Plus
C3	0.1 μ F	C1005X7R1H104K050BB	TDK
FB1	-	MMZ1005A222E	TDK
L1, L4	6.2 nH	0402HP-6N2XGLW	Coilcraft
L2, L3	6.8 nH	0402HP-6N8XGLW	Coilcraft

Notes:

1. RF blocking capacitors should be high performance, low-loss, broadband capacitors for optimum performance.
2. RC filtering on the control lines is recommended to prevent digital noise from coupling to the RF path.
 - a. Select control line RC filter values based on desired logic source decoupling and switching speed.

AM3035 – Tunable Filter

Digitally Tunable 500 to 1200 MHz Lowpass

Smallest Footprint

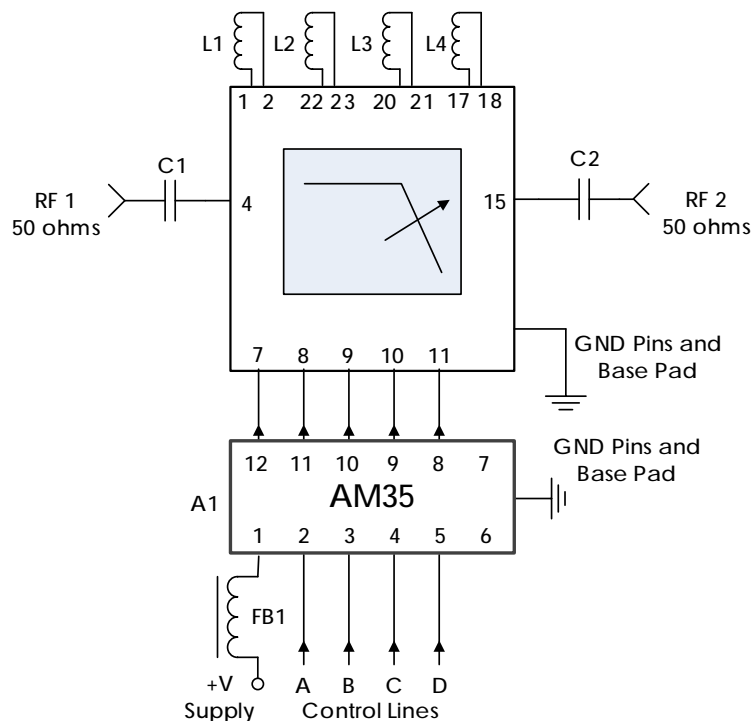

Recommended Component List (or equivalent):

Part	Value	Part Number	Manufacturer
C1, C2	0.1 uF	0402BB104KW160	Passives Plus
FB1	-	MMZ1005A222E	TDK
L1, L4	6.2 nH	0402HP-6N2XGLW	Coilcraft
L2, L3	6.8 nH	0402HP-6N8XGLW	Coilcraft
A1	-	AM35	Atlanta Micro

Notes:

1. RF blocking capacitors should be high performance, low-loss, broadband capacitors for optimum performance
2. AM35 provides power and control line filtering with high frequency isolation to 40+ GHz.
 - a. AM35 is a 1.5mm x 3mm (0.5mm pitch) EMI filter bank providing a small total footprint for applications with tight space requirements.
 - b. Ferrite bead in series with power line provides better low frequency isolation.
 - c. See AM35 datasheet for performance details.

AM3035 – Tunable Filter

Digitally Tunable 500 to 1200 MHz Lowpass

Evaluation PC Board

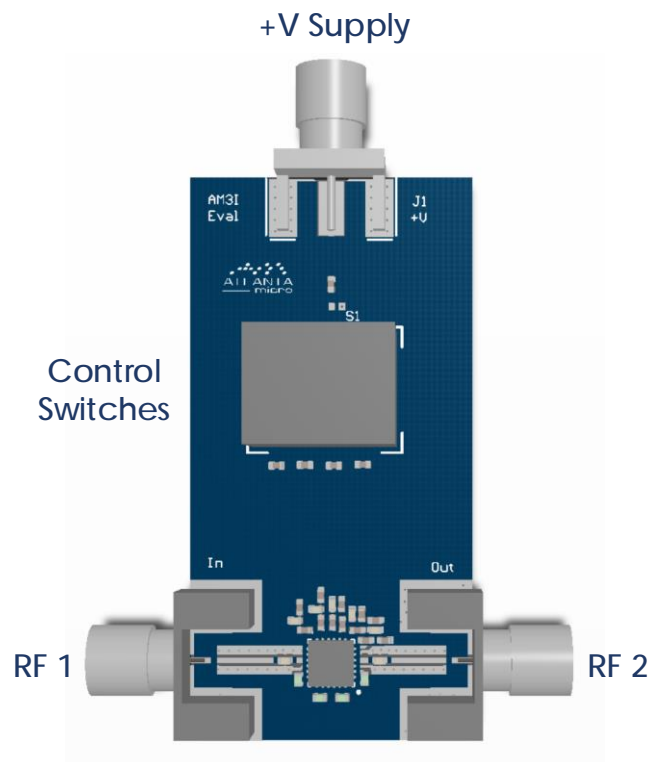

Related Parts

Part Number	Description		
AM35	100 MHz	to	40 GHz Stopband, EMI filter bank
AM3150	30 MHz	to	550 MHz Digitally Tunable Lowpass
AM3034	150 MHz	to	450 MHz Digitally Tunable Lowpass
AM3029	1.5 GHz	to	3.0 GHz Digitally Tunable Lowpass
AM3107	6 GHz	to	12 GHz Digitally Tunable Lowpass
AM3151	20 MHz	to	320 MHz Digitally Tunable Highpass
AM3033	100 MHz	to	225 MHz Digitally Tunable Highpass
AM3036	330 MHz	to	700 MHz Digitally Tunable Highpass
AM3031	1.0 GHz	to	1.8 GHz Digitally Tunable Highpass
AM3032	2.5 GHz	to	4.5 GHz Digitally Tunable Highpass
AM3041	6 GHz	to	10 GHz Digitally Tunable Highpass

To obtain price, delivery, or to place an order contact MMICSales@mercy.com
 Atlanta Micro Inc., 3720 Davinci Ct, Suite 400, Peachtree Corners, GA 30092 • Phone: (470) 253-7640 • www.atlantamicro.com

AM3035 – Tunable Filter

Digitally Tunable 500 to 1200 MHz Lowpass

Component Compliance Information

RoHS: Atlanta Micro, Inc. hereby certifies that all products comply with the EC Directive 2011/65/EC on the Restriction of Hazardous Substances, commonly known as EU-RoHS 6 and 10. All products supplied by Atlanta Micro shall be compliant with the European Directive 2011/65/EC based on the following substance list.

Substance List	Allowable Maximum Concentration
Lead (Pb)	<1000 PPM (0.1% by weight)
Mercury (Hg)	<1000 PPM (0.1% by weight)
Cadmium (Cd)	<75 PPM (0.0075% by weight)
Hexavalent Chromium (CrVI)	<1000 PPM (0.1% by weight)
Polybrominated Biphenyls (PBB)	<1000 PPM (0.1% by weight)
Polybrominated Diphenyl ethers (PBDE)	<1000 PPM (0.1% by weight)
Decabromodiphenyl Deca BDE	<1000 PPM (0.1% by weight)
Bis (2-ethylhexyl) Phthalate (DEHP)	<1000 PPM (0.1% by weight)
Butyl Benzyl Phthalate (BBP)	<1000 PPM (0.1% by weight)
Dibutyl Phthalate (DBP)	<1000 PPM (0.1% by weight)
Diisobutyl Phthalate (DIBP)	<1000 PPM (0.1% by weight)

REACH: Atlanta Micro, Inc. neither uses nor intentionally adds any of the substances considered to be a Substance of Very High Concern (SVHC) as defined by the EU Regulation (EC) No. 1907-2006 on Registration, Evaluation, Authorization, and Restriction of Chemicals (REACH).

Conflict Materials: Atlanta Micro does not knowingly use materials that are sourced from the Democratic Republic of Congo (DRC) or any other known conflict regions. Atlanta Micro's supply chain is comprised of sources that are both environmentally and socially responsible. We periodically review this requirement with our vendors to ensure continued compliance.

Atlanta Micro takes its responsibility as a global partner seriously and will use due diligence within our supply chain to ensure all standards are met to the best of our knowledge.