

QFN150P1900x2050x400-20 Package Details

Metal 19.0mm x 20.5mm 20 Lead QFN

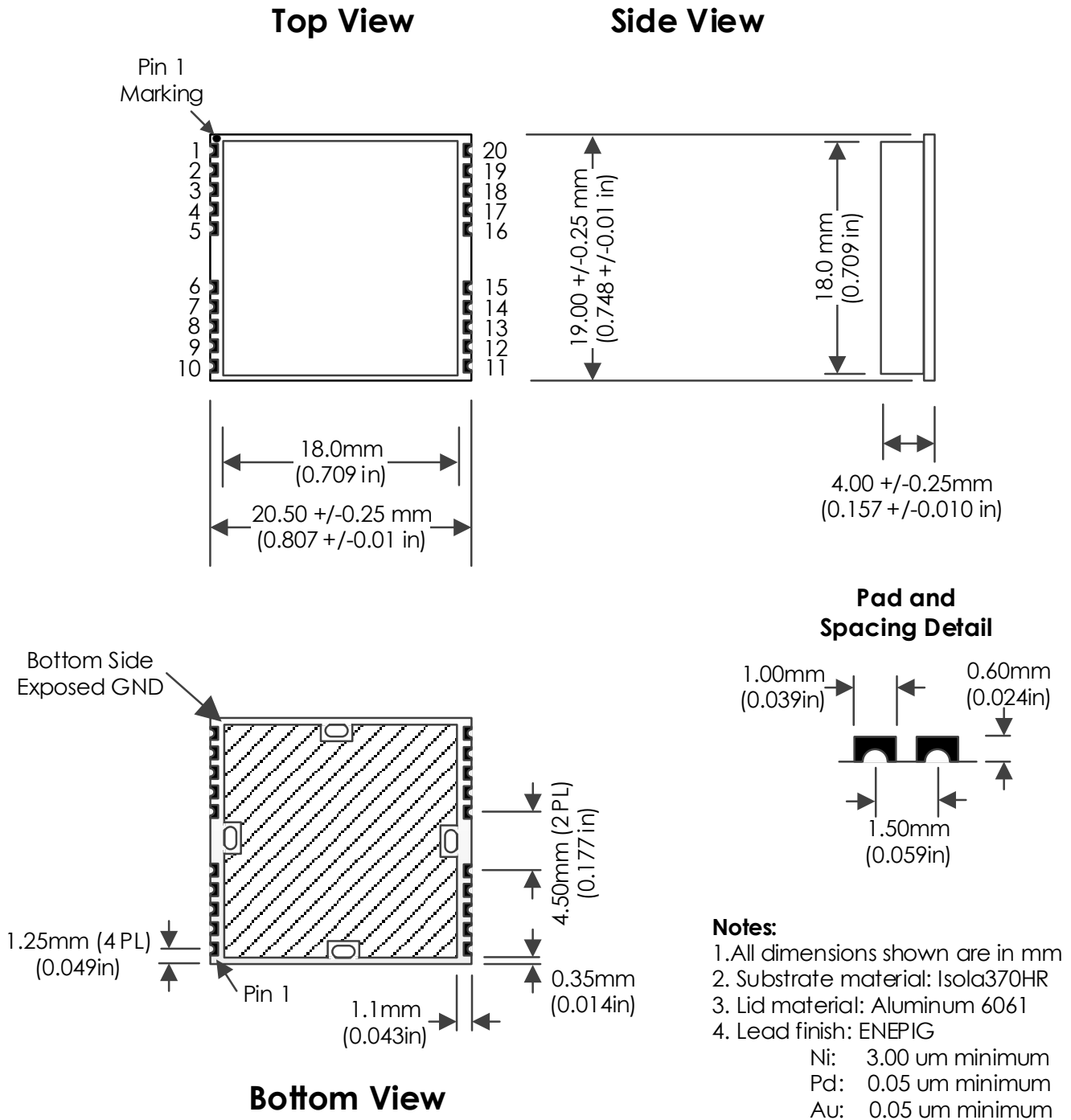

Package Drawing



QFN150P1900x2050x400-20 Package Details

Metal 19.0mm x 20.5mm 20 Lead QFN

Recommended Footprint

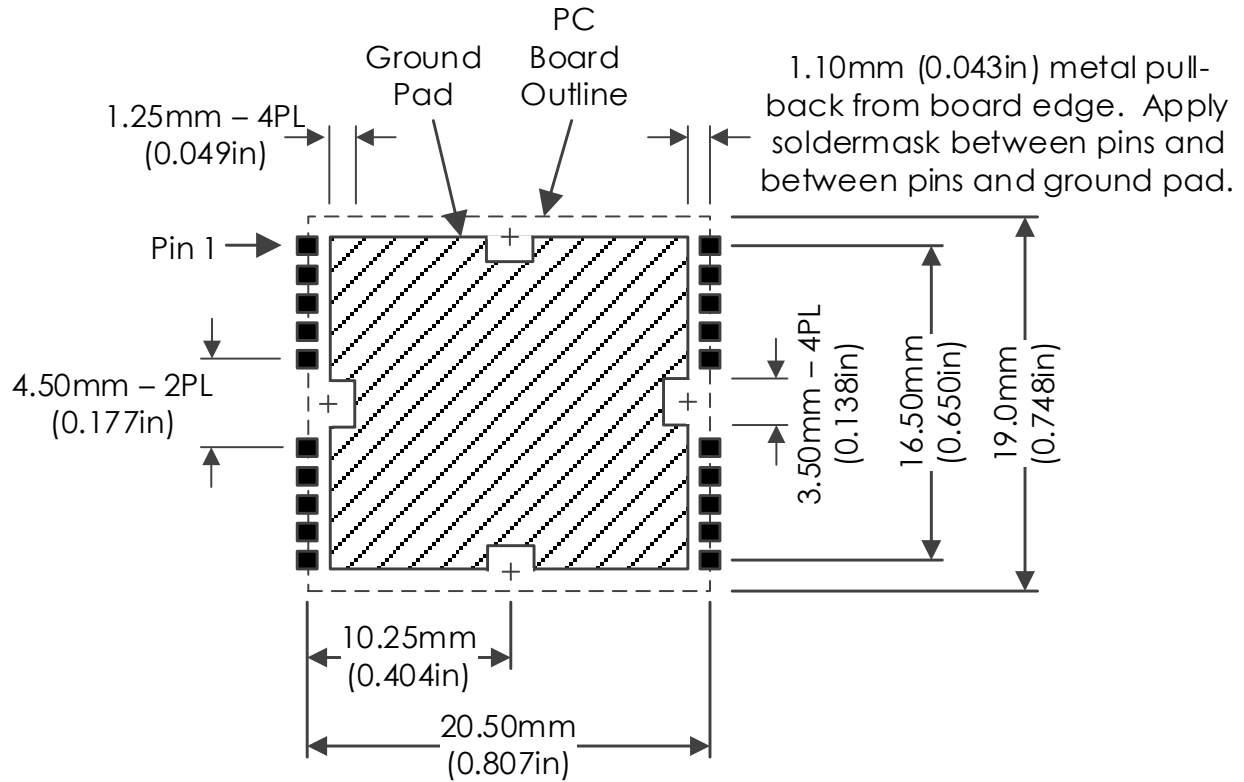

Pad and Spacing Detail

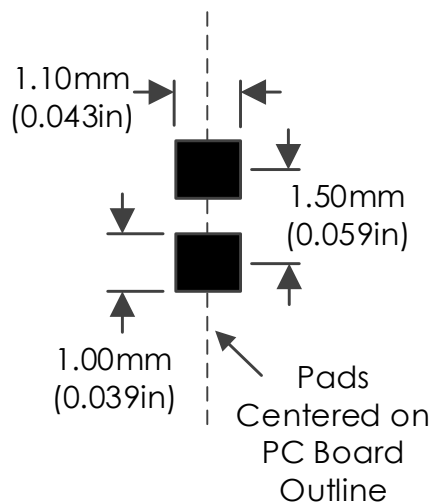

QFN150P1900x2050x400-20 Package Details

Metal 19.0mm x 20.5mm 20 Lead QFN



Recommended Assembly Procedure

It is recommended to attach the bottom side ground pad to the printed circuit board using a highly conductive silver epoxy and then hand solder the 20 pins along the part's perimeter to their intended printed circuit board pads using lead-free solder.

The recommended silver epoxy is MG Chemicals part 8331S and the recommended assembly thickness is 3 to 5 mils.

If the device is to be attached (both the ground pad and perimeter pins) to the circuit board using a typical lead-free solder reflow process reaching temperatures of 260C, the excessive temperature can cause internal parts to the filter bank to reflow and result in damage to the device. If a solder reflow process must be used, it is recommended to use a lower temperature leaded solder profile, typically 225C maximum.

Package Naming Convention

- QFN** - Quad Flat No-Lead
- 150** - Pitch = 1.50mm
- 1900** - Body Width = 19.00mm
- 2050** - Body Length = 20.50mm
- 400** - Height = 4.00mm
- 20** - Pin Quantity

*Based on IPC-7351B naming convention

Revision History

Date	Revision Number	Notes
April 8, 2020	1	Initial Release
August 18, 2020	1.1	Footprint Corrected