

# AM1113 – Amplifier

## 2 GHz to 18 GHz Slope Correcting Gain Block

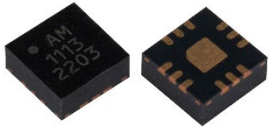

**AM1113 is a wideband, cascadable amplifier servicing the 2 to 18 GHz frequency range.** The device exhibits low gain at the lower frequencies ascending to moderate gain at the higher frequencies. The increasing gain across frequency makes the AM1113 an ideal solution to equalize gain/insertion loss across an RF system. Packaged in a 3mm QFN with internal 50Ω matching and drawing less than 200mW of power, the AM1113 is suited for low SWaP applications.

### FEATURES

- 7 dB Gain Slope
- 5.6 dB Gain at 2 GHz
- 12.4 dB Gain at 18 GHz
- 3.5 dB Noise Figure
- +30 dBm OIP3
- +17 dBm P1dB
- +3.3V Operation
- 198 mW Power Consumption
- 3mm QFN
- -40C to +85C Operation

### FUNCTIONAL DIAGRAM

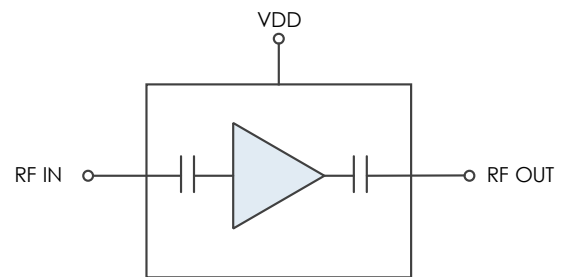

### CHARACTERISTIC PERFORMANCE

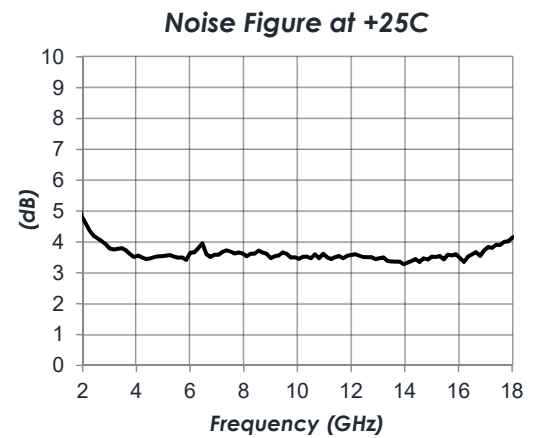
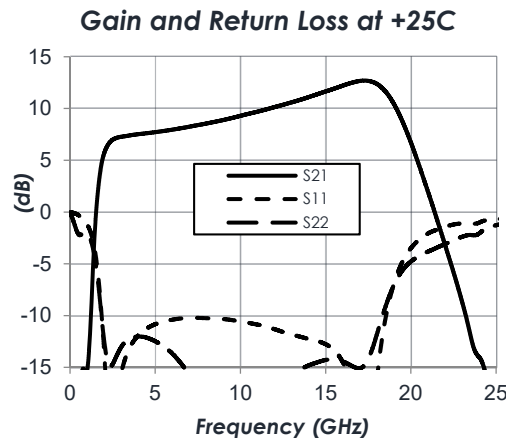

CONTENTS

REVISION HISTORY ..... 2

PIN LAYOUT AND DEFINITIONS ..... 3

SPECIFICATIONS..... 4

TYPICAL PERFORMANCE ..... 6

TYPICAL APPLICATION..... 8

EVALUATION PC BOARD..... 9

RELATED PARTS ..... 9

COMPONENT COMPLIANCE INFORMATION ..... 10

REVISION HISTORY

Date	Revision	Notes
January 6, 2022	1	Initial Release
March 4, 2024	2	Updated Plots.
June 20, 2024	3	Changed to Mercury branding. No content changes.

PIN LAYOUT AND DEFINITIONS

Note: All Un-Labeled Pins are NC or Ground

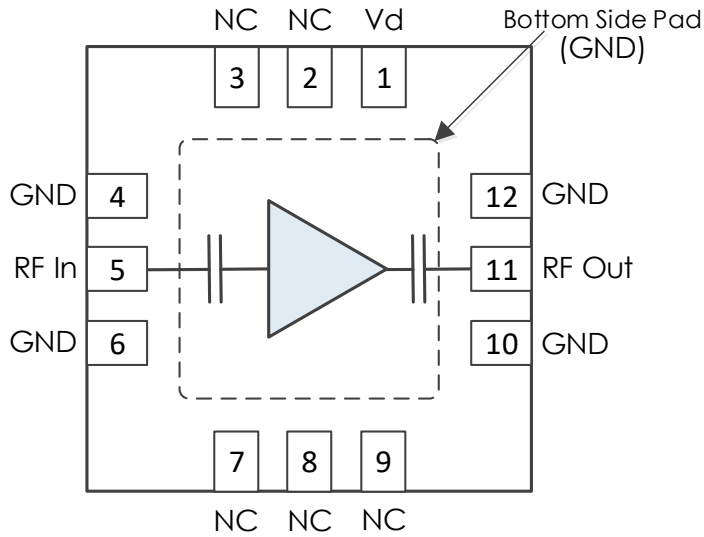

Pin	Name	Function
1	Vd	DC Power Input
2-3	NC	Not Connected
4	GND	Ground - Common
5	RF In	RF Input - 50 Ohms - DC Blocked
6	GND	Ground - Common
7-9	NC	Not Connected
10	GND	Ground - Common
11	RF Out	RF Output - 50 Ohms - DC Blocked
12	GND	Ground - Common

**Note:** NC pins may be grounded or left open.

SPECIFICATIONS

Absolute Maximum Ratings

	Minimum	Maximum
Supply Voltage	-0.3 V	+3.5 V
RF Input Power		+20 dBm
Storage Temperature Range	-55 C	+150 C

**Note:** Any device operation beyond the Absolute Maximum Ratings may result in permanent damage to the device. The values listed in this table are extremes and do not imply functional operation of the device at these or any other conditions beyond what is listed under Recommended Operating Conditions. Any part subjected to conditions outside of what is recommended for an extended amount of time may suffer from reliability concerns.

Handling Information

	Minimum	Maximum
Storage Temperature Range (Recommended)	-50 C	+125 C
Moisture Sensitivity Level	MSL 3	



Mercury products are electrostatic sensitive. Follow safe handling practices to avoid damage.

Recommended Operating Conditions

	Minimum	Typical	Maximum
Supply Voltage		+3.3 V	
Operating Case Temperature	-40 C		+85 C

Thermal Information

	Thermal Resistance (°C /W)
Junction to Case Thermal Resistance ( $\theta_{JC}$ )	288 C/W
Nominal Junction Temperature at +85C Ambient	+142 C
Channel Temperature to Maintain 1 Million Hour MTTF	+175 C

**DC Electrical Characteristics**

(T = 25 °C unless otherwise specified)

Param	Testing Conditions	Min	Typical	Max
DC Supply Voltage			+3.3 V	
DC Supply Current	VDD = +3.3 V		60 mA	
Power Dissipated	VDD = +3.3 V		198 mW	

**RF Performance**

(T = 25 °C unless otherwise specified)

Param	Testing Conditions	Min	Typical	Max
Frequency Range		2 GHz		18 GHz
Gain	f = 2 GHz		5.6 dB	
	f = 10 GHz		9.3 dB	
	f = 18 GHz		12.4 dB	
Return Loss	f = 2 GHz		-15 dB	
	f = 10 GHz		-9 dB	
	f = 18 GHz		-10 dB	
Output IP3	f = 10 GHz		30 dBm	
Output P1dB	f = 10 GHz		17 dBm	
Noise Figure	f = 10 GHz		3.5 dB	

**Note:** OIP3 measured with 10MHz tone spacing.

TYPICAL PERFORMANCE

(VDD = +3.3V, T = 25 °C unless otherwise specified)

Gain vs Temperature

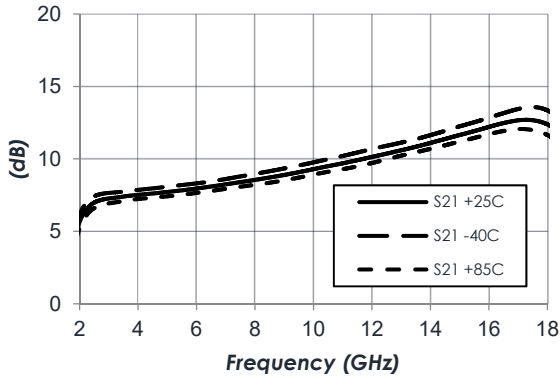

Noise Figure vs Temperature

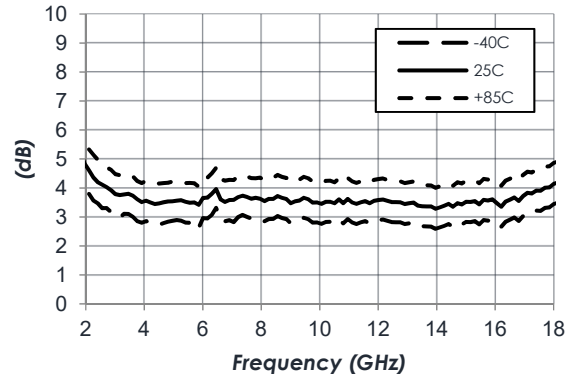

Output IP3 vs Temperature

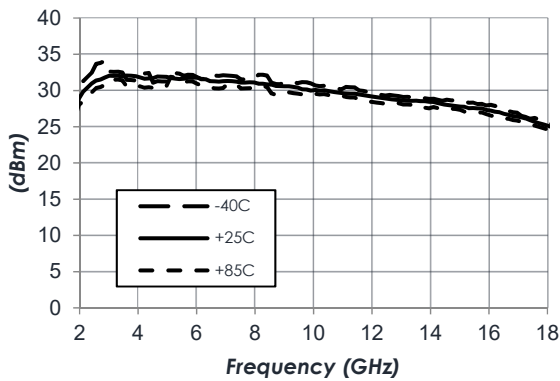

P1dB vs Temperature

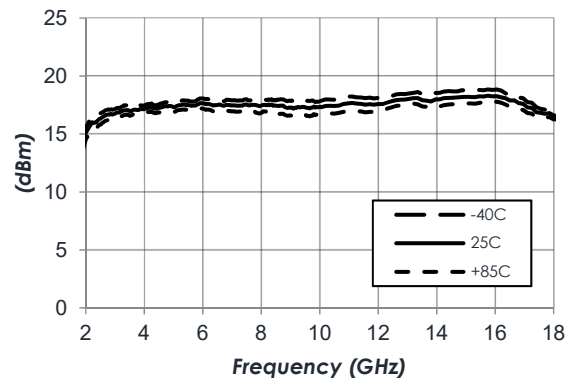

Reverse Isolation vs Temperature

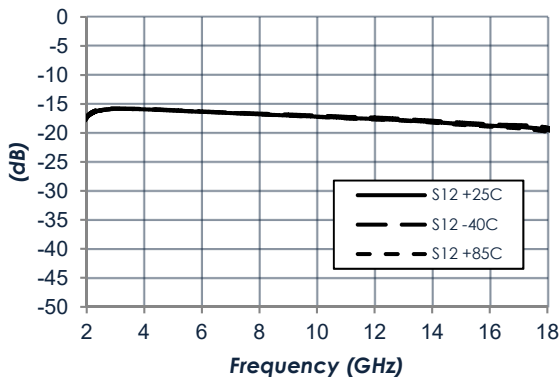

P\_Sat vs Temperature

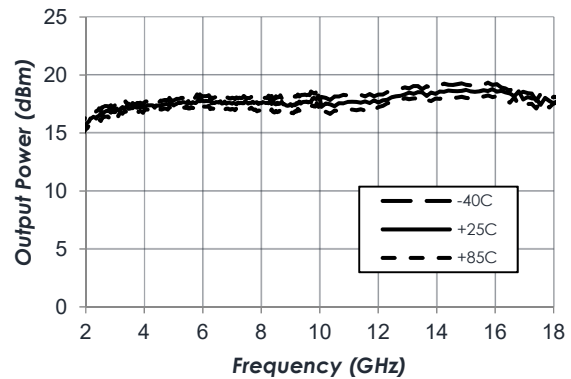

TYPICAL PERFORMANCE (CONTINUED)

(VDD = +3.3V, T = 25 °C unless otherwise specified)

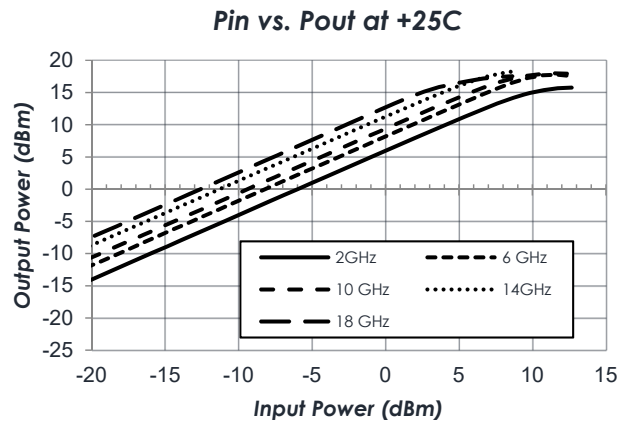

TYPICAL APPLICATION

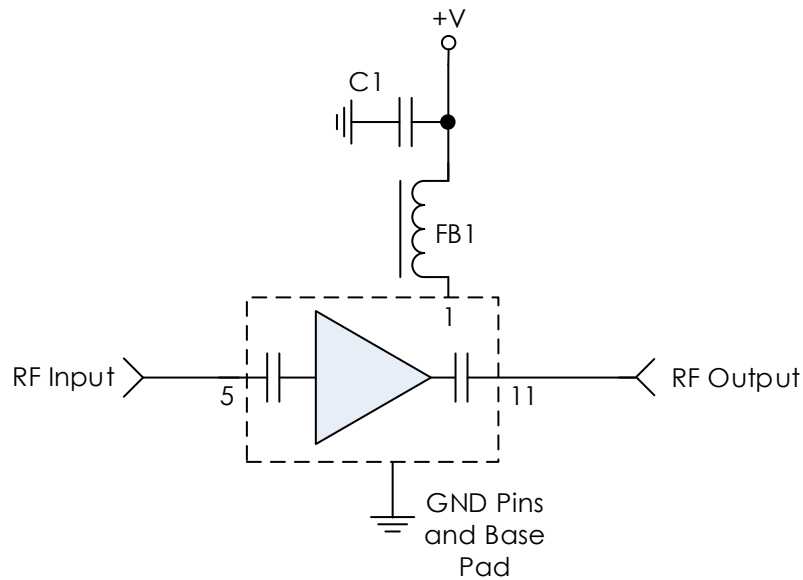

**Note:** NC pins may be grounded or left open.

**Recommended Component List (or Equivalent)**

Part	Value	Part Number	Manufacturer
C1	0.1 uF	GRM155R71C104KA88	Murata
FB1	-	MMZ1005A222E	TDK

**Notes:**

1. FB1 and C1 are required for proper operation of the AM1113.
  - a. AM1113 **must** see a large-valued inductor or ferrite bead at pin 1 before a shunt capacitor is to be placed for power line filtering.
  - b. If a capacitor is placed at pin 1 before FB1, AM1113 will not operate as shown in Typical Performance section.



EVALUATION PC BOARD

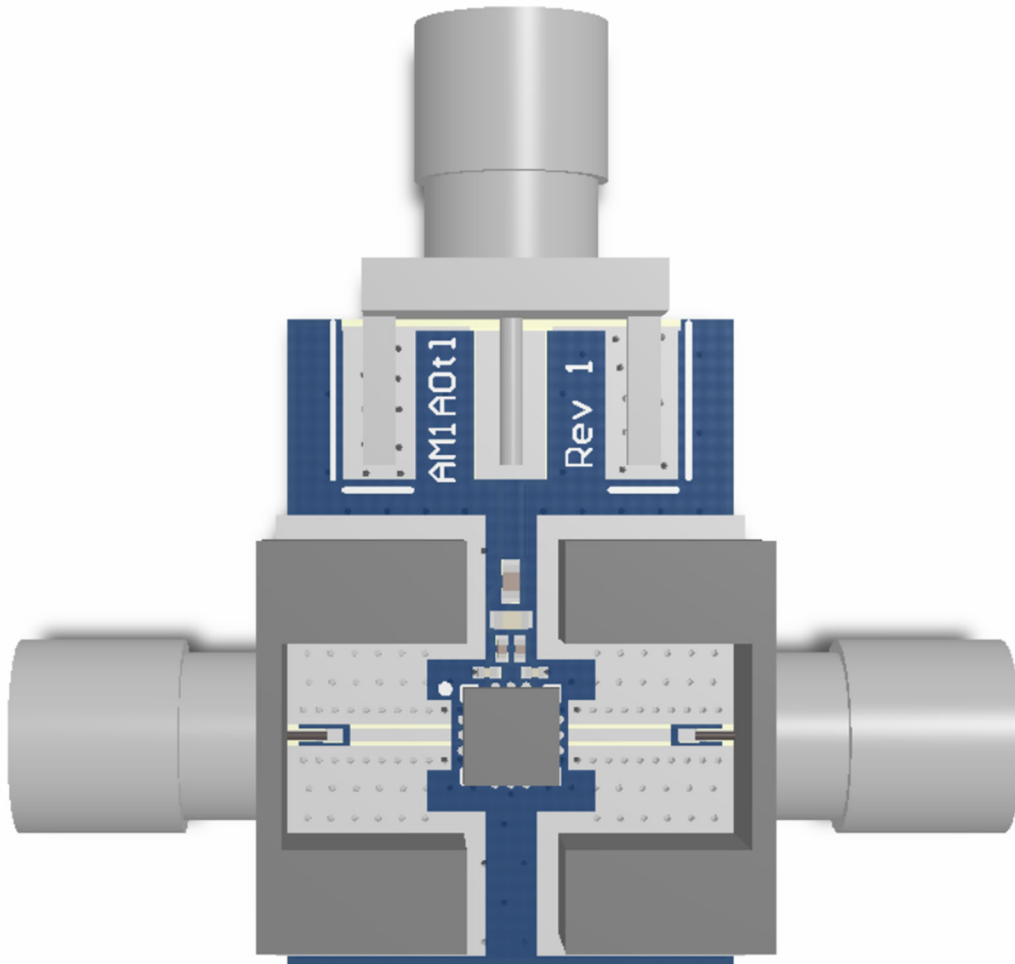

**Note:** Not all components shown may be installed.

RELATED PARTS

Part Number		Description
AM1070	DC to 18 GHz	Broadband Gain Block
AM1071	DC to 18 GHz	Broadband Gain Block
AM1100	2 GHz to 16.5 GHz	Low Noise Amplifier
AM1101	2 GHz to 26.5 GHz	Bypassable Amplifier
AM1102	DC to 22 GHz	Low Noise Amplifier
AM1110	DC to 18 GHz	Slope Correcting Amplifier
AM1114	2 GHz to 18 GHz	Slope Correcting Amplifier

COMPONENT COMPLIANCE INFORMATION

**RoHS:** Mercury Systems, Inc. hereby certifies that all products comply with the EC Directive 2011/65/EC on the Restriction of Hazardous Substances, commonly known as EU-RoHS 6 and 10. All products supplied by Mercury shall be compliant with the European Directive 2011/65/EC based on the following substance list.

Substance List	Allowable Maximum Concentration
Lead (Pb)	<1000 PPM (0.1% by weight)
Mercury (Hg)	<1000 PPM (0.1% by weight)
Cadmium (Cd)	<75 PPM (0.0075% by weight)
Hexavalent Chromium (CrVI)	<1000 PPM (0.1% by weight)
Polybrominated Biphenyls (PBB)	<1000 PPM (0.1% by weight)
Polybrominated Diphenyl ethers (PBDE)	<1000 PPM (0.1% by weight)
Decabromodiphenyl Deca BDE	<1000 PPM (0.1% by weight)
Bis (2-ethylhexyl) Phthalate (DEHP)	<1000 PPM (0.1% by weight)
Butyl Benzyl Phthalate (BBP)	<1000 PPM (0.1% by weight)
Dibutyl Phthalate (DBP)	<1000 PPM (0.1% by weight)
Diisobutyl Phthalate (DIBP)	<1000 PPM (0.1% by weight)

**REACH:** Mercury Systems, Inc. neither uses nor intentionally adds any of the substances considered to be a Substance of Very High Concern (SVHC) as defined by the EU Regulation (EC) No. 1907-2006 on Registration, Evaluation, Authorization, and Restriction of Chemicals (REACH).

**Conflict Materials:** Mercury does not knowingly use materials that are sourced from the Democratic Republic of Congo (DRC) or any other known conflict regions. Mercury’s supply chain is comprised of sources that are both environmentally and socially responsible. We periodically review this requirement with our vendors to ensure continued compliance.

**Mercury takes its responsibility as a global partner seriously and will use due diligence within our supply chain to ensure all standards are met to the best of our knowledge.**



**Corporate Headquarters**

50 Minuteman Road  
 Andover, MA 01810 USA  
 +1 978.967.1401 tel  
 +1 866.627.6951 tel  
 +1 978.256.3599 fax

**International Headquarters**

**Mercury International**  
 Avenue Eugène-Lance, 38  
 PO Box 584  
 CH-1212 Grand-Lancy 1  
 Geneva, Switzerland  
 +41 22 884 5100 tel

**Learn more**

**Visit:** [mrcy.com](http://mrcy.com)

For pricing details, contact: [MMICsales@mrcy.com](mailto:MMICsales@mrcy.com)

For technical details, contact: [MMICsupport@mrcy.com](mailto:MMICsupport@mrcy.com)



The Mercury Systems logo is a registered trademark of Mercury Systems, Inc. Other marks used herein may be trademarks or registered trademarks of their respective holders. Mercury products identified in this document conform with the specifications and standards described herein. Conformance to any such standards is based solely on Mercury’s internal processes and methods. The information contained in this document is subject to change at any time without notice.

