

# RFFE-MCP-TR-001

## X-Band 4 Channel Front End Module

Revolutionary density meets uncompromising performance through chipletization.

- Purpose-Built Architecture, Accessible Design
- Agile Architecture from design to operation
- Next Generation RF Front End Module for
- COMMs, RADAR, and EW Applications

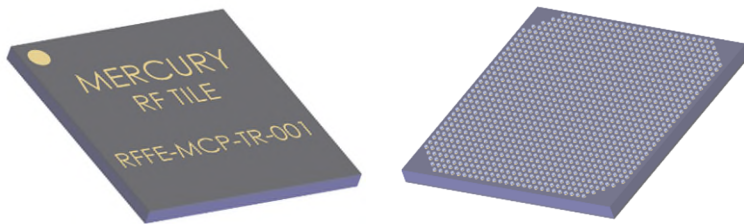

Mercury's RFFE-MCP-TR-001 is an X-Band Front End Module built on an ultracompact SiP architecture that provides high functional density and SWaPc optimized configurability across all production scales. With its MultiChip Package design, it enables rapid modification cycles that reduce development time and cost.

### Target Applications

#### Communications

- 5G/6G

#### Radar

- Meteorology
- Automotive Safety
- SAR
- Air Traffic Control (ATC)
- Airport Surveillance Radar (ASR)
- Radar Altimeters (RA)

#### Direct RF

- Test Equipment
- Handheld Radios
- Law enforcement
- SATCOM

#### EW/SIGINT

- Countermeasures
- Cognitive EW
- Threat Detection
- WB Signal Acquisition

### Target Platforms

#### Attritables

- Deployed Effect Systems
- Drones

#### Vehicles

- Ground
- Airborne
- Seaborne
- Satellite

#### Lab use

- Standalone eval board
- Custom PCB designs
- Rack mount

#### AESA apertures

- Communications
- Radar
- Direct RF
- EW/SIGINT
- C-UAS

Developed entirely within Mercury, the design allows full customization at every layer, ensuring precise alignment with custom, mission specific requirements.

Sized for Attritable platforms and scalable to AESA apertures, the module delivers substantial density improvements while maintaining advanced SoC class RF performance. The MCP architecture supports accelerated development through shortened prototype verification loops and efficient transition to medium volume manufacturing.

## RF Functional Diagram

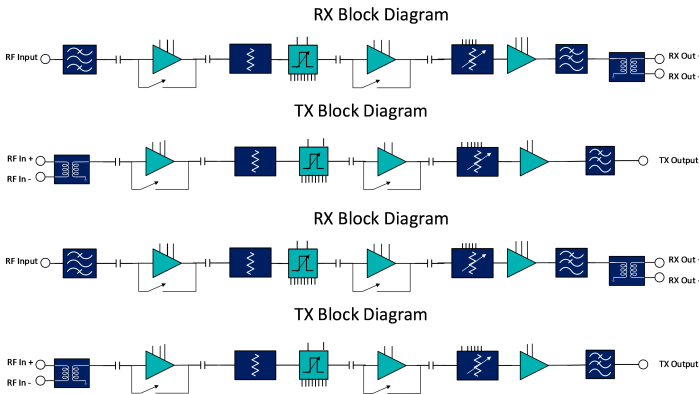

## Control Functional Diagram

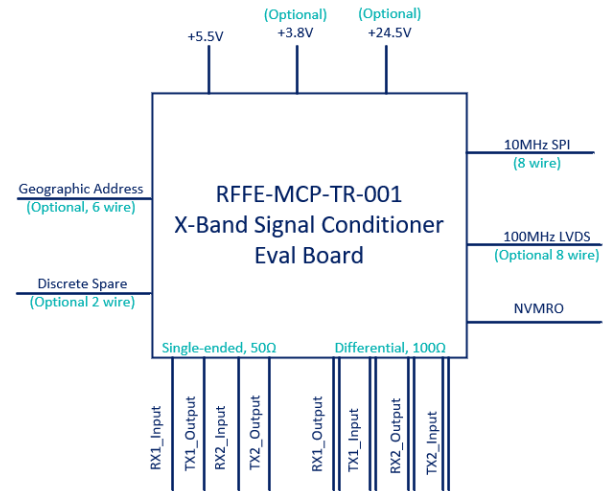

## TECHNICAL SPECIFICATIONS

Component Interface	Eval Board	MCP
Physical Size (RFFE-MCP-TR)	2.5" x 1.9" x 1.0"	28mm x 28mm x 2mm
Form Factor	Evaluation Board	0.8 mm pitch BGA
DC Power Supply	+5.5V	+5V, +3.3V, -10V
REF IN	100Ω differential input 100MHz Required	100Ω differential input 100MHz Required
Communication Interface	10MHz Multi-point SPI 100MHz LVDS	Discrete Line 40MHz SPI
Environmental Target	Lab use only	Compatible with MIL-PRF-38534, Class H and MIL-STD-883
Evaluation Suite	Available	N/A

** RF Performance	TX Path	Rx Path
# Channels	2x RX	2x TX
RF Interface	50Ω single-ended TX Output	100Ω differential RX Output
	100Ω differential TX Input	50Ω single-ended TX Output
Operating Frequency	8-12GHz	8-12GHz
Instantaneous Bandwidth	3.5%/7% typical, tunable across operating range	3.5%/7% typical, tunable across operating range
Gain	+25 dB typ +20 dB min	+25 dB typ +20 dB min
Noise Figure	10dB typ 15 dB max	7 dB typ 8dB max
Output P1dB	+17 dBm typ. +14 dBm min	+13 dBm typ. +10 dBm min
Power (Typical per channel)	1.2W enabled 0.7W bypass state	1.0W enabled 0.6W bypass state
VSWR In/Out	1.5:1 typ. 2:1 Max.	1.5:1 typ. 2:1 Max.
Dynamic Range (simulated)	70 dB (target)	70 dB (target)
Maximum Input Power	+20 dBm max	+20 dBm max
Gain Control	31.0 dB range 1dB step	31.0 dB range 1dB step

\* Without optional limiter

\*\* Performance in nominal, non-bypassed, 0dB DSA operating state.

## Outline Drawings

### Eval Board

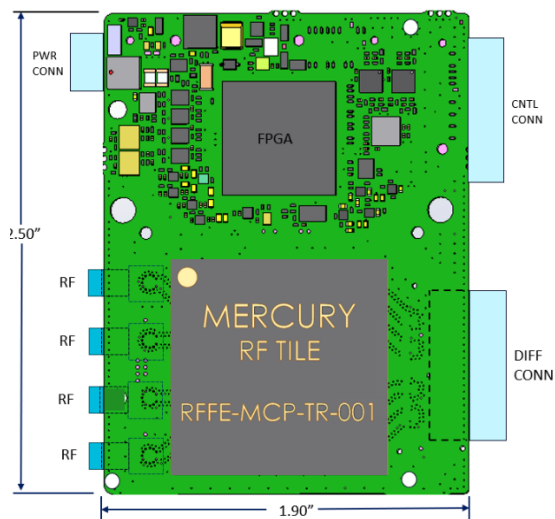

### MCP

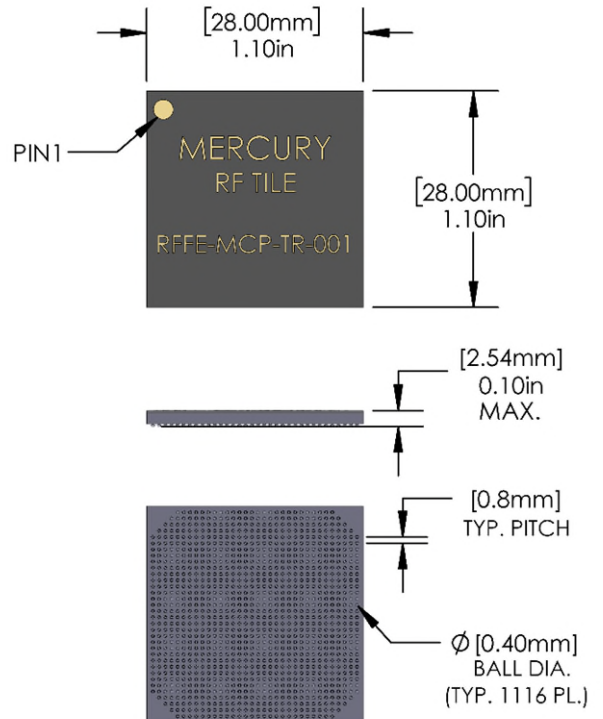

1:1 Scale, when printed fit to 8.5"x11" paper

## Product Description

### Highlights

- RF Tile 28mm<sup>2</sup> BGA.
  - Evaluation PCB 1.9"x2.5"
- 2x Receive Channels
  - Single Ended RF Input
  - Differential Output to ADC
  - Optional Input Limiter for higher power handling
- 2x Transmit Channels
  - Differential Input from DAC
- Single Ended RF Output
- Optional Output MPA for higher P1dB/Psat
- Independent control of every channel
  - Electrically adjustable center frequency
  - Electrically adjustable bandwidth
  - Digital step attenuation (31dB in 1dB steps)
  - Internal bypass state for increased dynamic range
- Evaluation board available

- Single +5.5V Input Voltage-capable
- 10MHz SPI Interface



#### Corporate Headquarters

50 Minuteman Road  
Andover, MA 01810 USA  
+1 978.967.1401 tel  
+1 866.627.6951 tel  
+1 978.256.3599 fax

#### International Headquarters Mercury International

Avenue Eugène-Lance, 38  
PO Box 584  
CH-1212 Grand-Lancy 1  
Geneva, Switzerland  
+41 22 884 51 00 tel

#### Learn more

Visit: [mrcy.com/contact-us](https://mrcy.com/contact-us)

Contact: [mrcy.com/contact-us](https://mrcy.com/contact-us)

