

# AM3195 – Filter Bank

## 2 to 18 GHz Amplified Sub-Octave Filter Bank

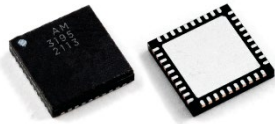

**AM3195 is a wideband pre-selector servicing the 2 to 18 GHz frequency range.**

The device provides the ability to set the front end of a receiver to a low noise figure while providing high linearity and moderate gain. The AM3195’s ability to condense a preselector filter and LNA into a single package makes it ideal for SWaP applications. The device is packaged in a 6mm QFN and draws less than 300mW of power.

### FEATURES

- +6 dB Gain
- 6 dB Noise Figure
- +50 dBm OIP2
- +10 dB P1dB
- +3.3V/5V Operation
- < 300 mW Power Consumption
- 6mm QFN
- -40C to +85C Operation

### FUNCTIONAL DIAGRAM

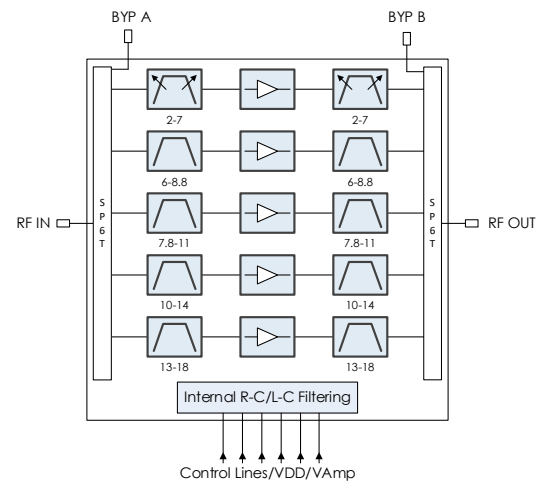

### CHARACTERISTIC PERFORMANCE

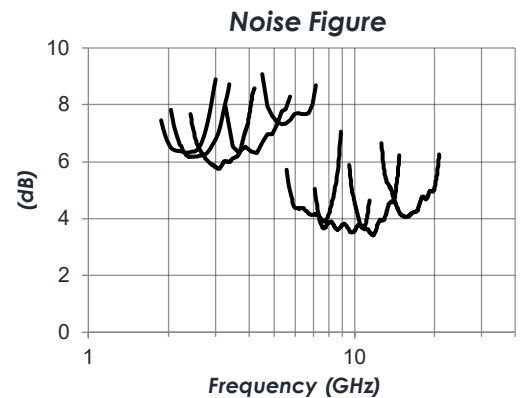
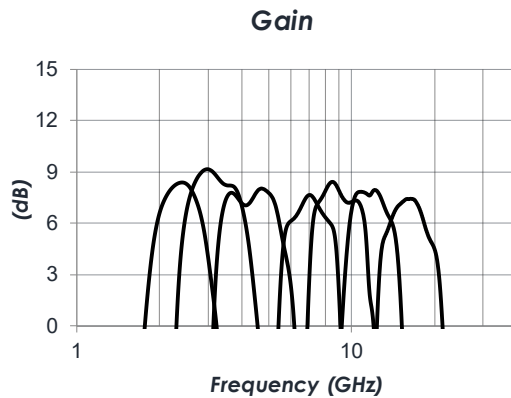

CONTENTS

REVISION HISTORY .....2

PIN LAYOUT AND DEFINITIONS.....3

PIN LAYOUT AND DEFINITIONS (CONTINUED).....4

SPECIFICATIONS .....5

TYPICAL PERFORMANCE.....8

TYPICAL APPLICATION..... 15

EVALUATION PC BOARD..... 16

RELATED PARTS..... 16

COMPONENT COMPLIANCE INFORMATION ..... 18

REVISION HISTORY

Date	Revision	Notes
July 15, 2021	1	Initial Release
April 12, 2023	1.1	Functional Diagram Correction
March 28, 2024	1.2	Application diagram pin out correction

PIN LAYOUT AND DEFINITIONS

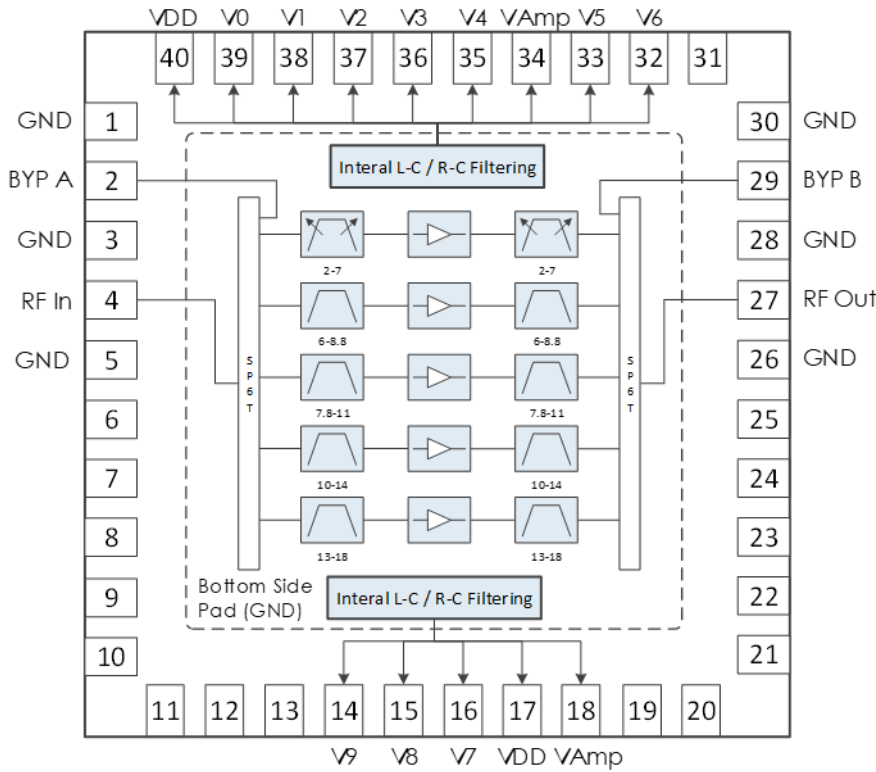

Pin	Name	Function
1	GND	Ground - Common
2	BYP A	Filter Bypass A Side - 50 Ohms - DC Coupled. External DC Blocking Capacitor Required
3	GND	Ground - Common
4	RF In	RF Input - 50 Ohms - DC Coupled. External DC blocking capacitor required
5	GND	Ground - Common
6 - 13	NC	Not Connected*
14	V9	Filter Control 9
15	V8	Filter Control 8
16	V7	Filter Control 7
17	VDD	+5V DC Power Input
18	VAmp	+3.3V DC Power Input
19 - 25	NC	Not Connected*
26	GND	Ground - Common
27	RF Out	RF Output - 50 Ohms - DC Coupled. External DC blocking capacitor required
28	GND	Ground - Common

\* Note: Pins may be grounded or left open.

PIN LAYOUT AND DEFINITIONS (CONTINUED)

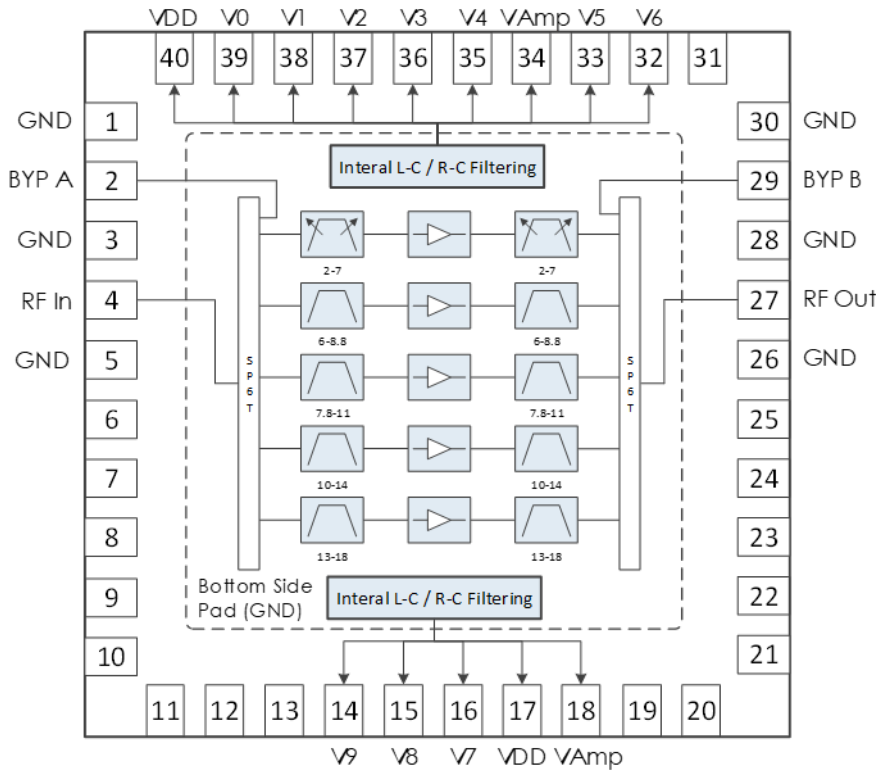

Pin	Name	Function
29	BYP B	Filter Bypass B Side – 50 Ohms – DC Coupled. External DC Blocking Capacitor Required
30	GND	Ground – Common
31	NC	Not Connected*
32	V6	Filter Control 6
33	V5	Filter Control 5
34	VAmp	+3.3 V DC Power Input
35	V4	Filter Control 4
36	V3	Filter Control 3
37	V2	Filter Control 2
38	V1	Filter Control 1
39	V0	Filter Control 0
40	VDD	+5V DC Power Input
Bottom Pad	GND	Ground – Common

\* Note: Pins may be grounded or left open.

SPECIFICATIONS

Absolute Maximum Ratings

	Minimum	Maximum
Supply Voltage, Amplifiers (V <sub>Amp</sub> )	-0.3 V	+3.5 V
Supply Voltage, Switches (V <sub>dd</sub> )	-0.3V	+6 V
RF Input Power		+20 dBm
Operating Junction Temperature	-40 C	+150 C
Storage Temperature Range	-55 C	+150 C

**Note:** Any device operation beyond the Absolute Maximum Ratings may result in permanent damage to the device. The values listed in this table are extremes and do not imply functional operation of the device at these or any other conditions beyond what is listed under Recommended Operating Conditions. Any part subjected to conditions outside of what is recommended for an extended amount of time may suffer from reliability concerns.

Handling Information

	Minimum	Maximum
Storage Temperature Range (Recommended)	-50 C	+125 C
Moisture Sensitivity Level	MSL 3	



Mercury products are electrostatic sensitive. Follow safe handling practices to avoid damage.

Recommended Operating Conditions

	Minimum	Typical	Maximum
Supply Voltage, Amplifiers (V <sub>Amp</sub> )	+3.0 V	+3.3 V	+3.3 V
Supply Voltage, Switches (V <sub>DD</sub> )	+2.5 V	+5.0 V	
Operating Case Temperature	-40 C		+85 C
Operating Junction Temperature	-40 C		+125 C

Required Power Sequencing

For safe, reliable use, it is recommended to apply power to V<sub>DD</sub> first and delay powering on V<sub>Amp</sub> until V<sub>DD</sub> has settled. When removing power, it is recommended to power down V<sub>Amp</sub> before V<sub>DD</sub>.

**DC Electrical Characteristics**

(VDD = +5.0V, VAmp = +3.3V, T = 25 °C unless otherwise specified)

Param	State	Min	Typical	Max
VAmp Current Consumed	Bypass		0 mA	
	Bands 1 to 8		63 mA	
	Band 9		45 mA	
	Band 10		33 mA	
	Band 11		31 mA	
	Band 12		49 mA	
VAmp Power Consumed	Bypass		0 mW	
	Bands 1 to 8		208 mW	
	Band 9		152 mW	
	Band 10		109 mW	
	Band 11		102 mW	
	Band 12		162 mW	
VDD Current Consumed	Bypass		3 mA	
	Bands 1 to 8		5 mA	
	Bands 9 to 12		3 mA	
VDD Power Consumed	Bypass		15 mW	
	Bands 1 to 8		25 mW	
	Bands 9 to 12		15 mW	

**RF Performance**

(VDD = +5.0V, VAmp = +3.3V, T = 25 °C unless otherwise specified)

Param	Testing Conditions	Min	Typical	Max
Frequency Range		2 GHz		18 GHz
Gain	f = 2 GHz, Band 1		6.6 dB	
	f = 10 GHz, Band 10		7.2 dB	
	f = 18 GHz, Band 12		6.4 dB	
Return Loss	f = 2 GHz, Band 1		12 dB	
	f = 10 GHz, Band 10		13 dB	
	f = 18 GHz, Band 12		11 dB	
Output IP3			21 dBm	
Output IP2			50 dBm	
Output P1dB			11 dBm	
Noise Figure			6 dB	

**State Table**

V0	V1	V2	V3	V4	V5	V6	V7	V8	V9	State	Low Cutoff	High Cutoff
0	0	1	0	0	1	0	x	x	x	Bypass		
0	0	1	0	0	0	1	0	0	0	Band 1	1.9 GHz	2.9 GHz
0	0	1	0	0	0	1	0	0	1	Band 2	1.9 GHz	3.2 GHz
0	0	1	0	0	0	1	0	1	0	Band 3	2.0 GHz	3.4 GHz
0	0	1	0	0	0	1	0	1	1	Band 4	2.2 GHz	3.6 GHz
0	0	1	0	0	0	1	1	0	0	Band 5	2.4 GHz	4.2 GHz
0	0	1	0	0	0	1	1	0	1	Band 6	2.7 GHz	4.8 GHz
0	0	1	0	0	0	1	1	1	0	Band 7	3.2 GHz	5.8 GHz
0	0	1	0	0	0	1	1	1	1	Band 8	4.4 GHz	7.2 GHz
0	0	1	0	1	0	0	x	x	x	Band 9	5.5 GHz	8.9 GHz
0	0	1	1	0	0	0	x	x	x	Band 10	7.1 GHz	11.4 GHz
0	1	0	0	0	0	0	x	x	x	Band 11	9.5 GHz	14.7 GHz
1	0	0	0	0	0	0	x	x	x	Band 12	12.6 GHz	20.7 GHz

TYPICAL PERFORMANCE

(VDD = +5.0V, VAmp = +3.3V, T = 25°C unless otherwise specified)

**Gain | Bands 1 to 6**

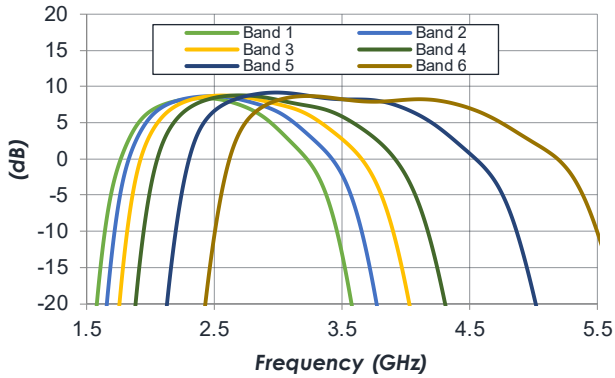

**Gain | Bands 7 to 12**

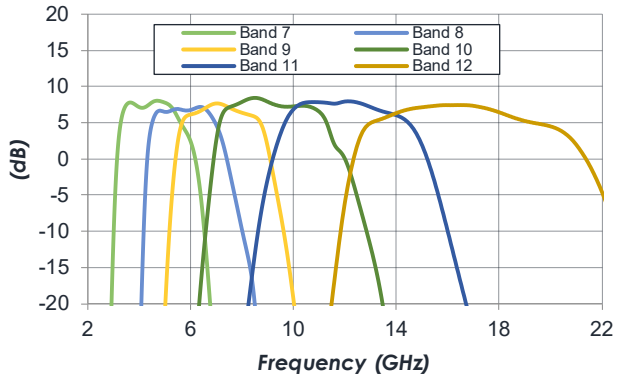

**Noise Figure | Bands 1 to 6**

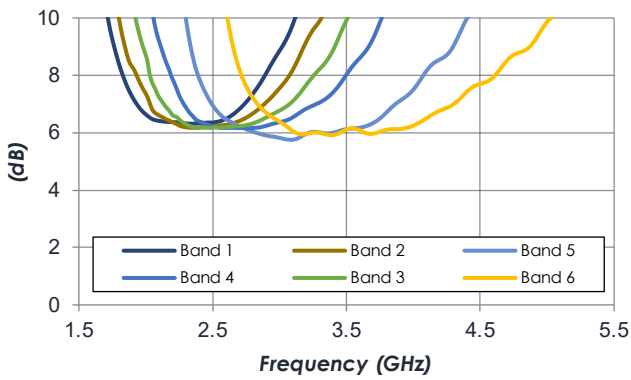

**Noise Figure | Bands 7 to 12**

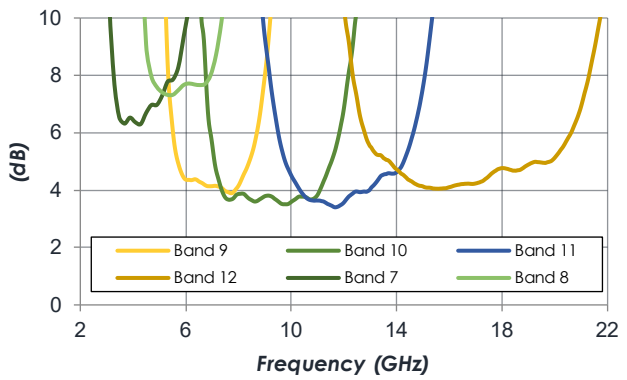

**OIP3 | Bands 1 to 6**

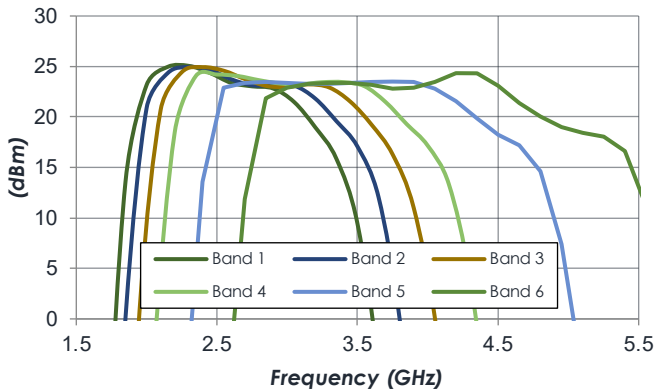

**OIP3 | Bands 7 to 12**

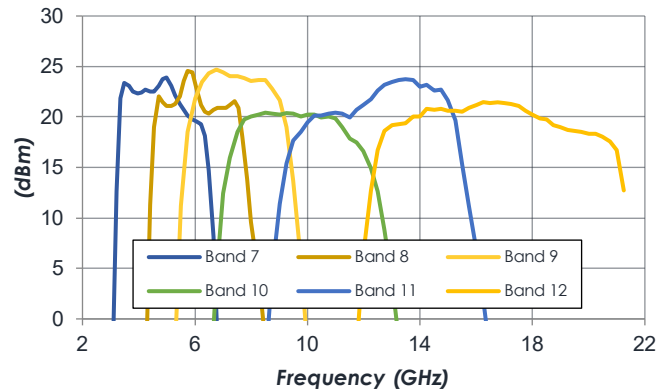

\*Note: ID = ID2 + IDSW

TYPICAL PERFORMANCE (CONTINUED)

(VDD = +5.0V, VAmp = +3.3V, T = 25°C unless otherwise specified)

**P1dB | Bands 1 to 6**

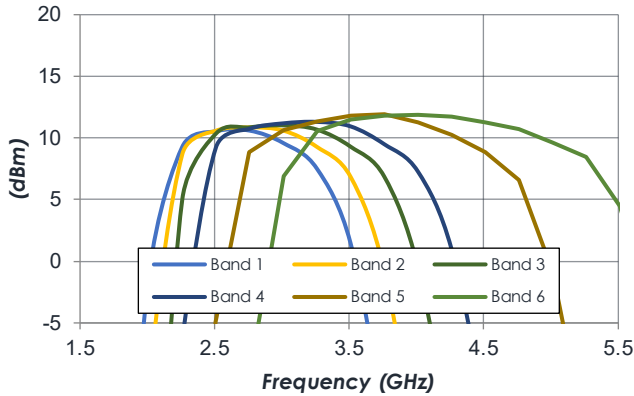

**P1dB | Bands 7 to 12**

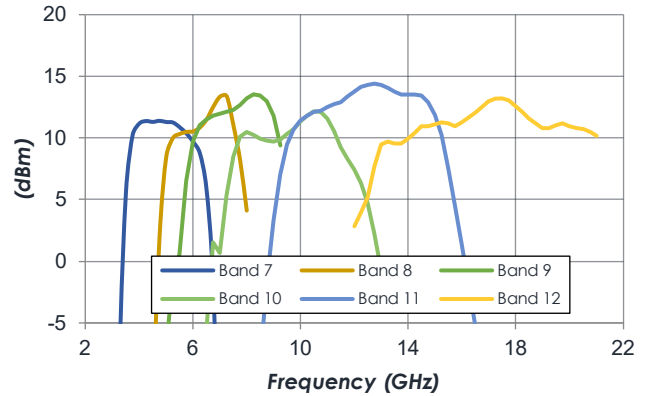

**OIP2 | Bands 1 to 4**

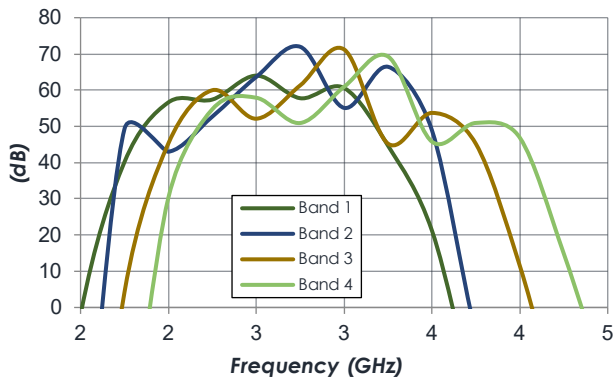

**OIP2 | Bands 5 to 8**

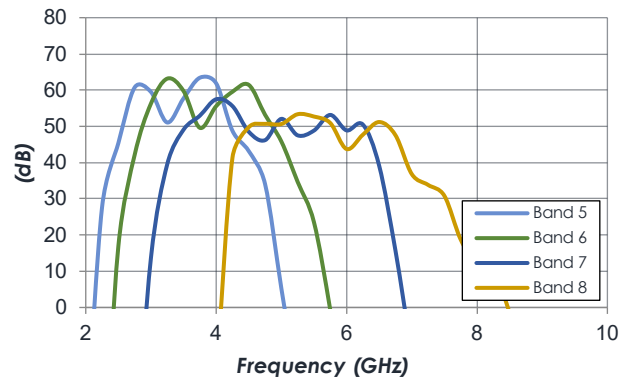

**OIP2 | Bands 9 to 12**

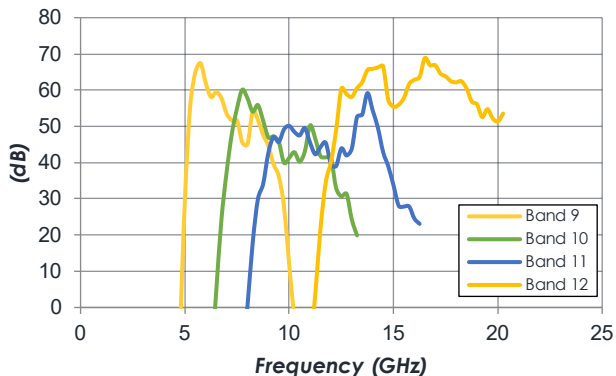

**Reverse Isolation | Bands 1 to 4**

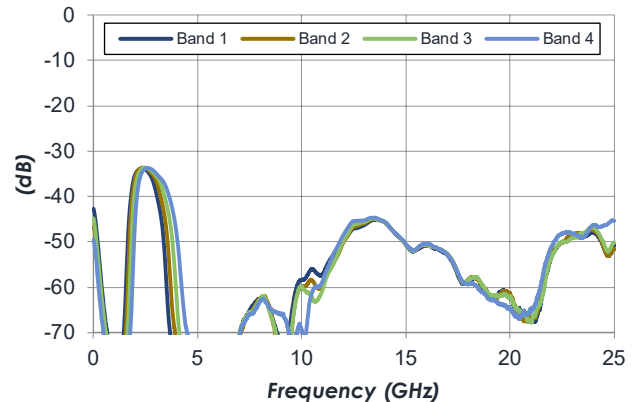

TYPICAL PERFORMANCE (CONTINUED)

(VDD = +5.0V, VAmp = +3.3V, T = 25°C unless otherwise specified)

Reverse Isolation | Bands 5 to 8

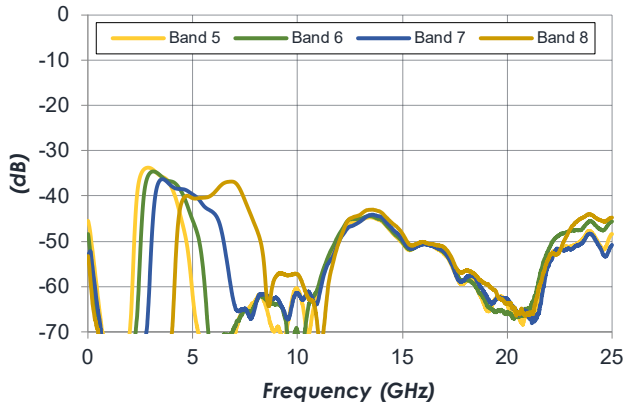

Reverse Isolation | Bands 9 to 12

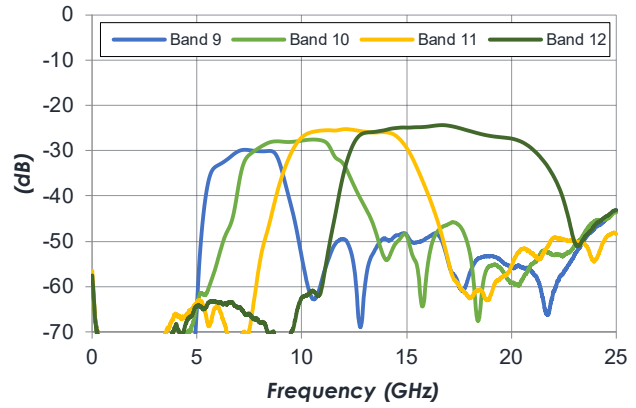

Return Loss | Bands 1 to 4

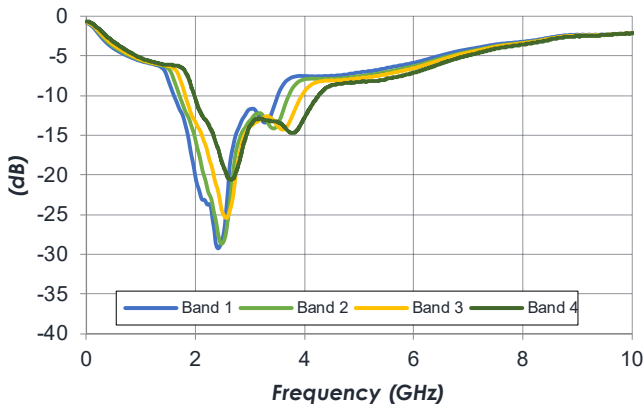

Return Loss | Bands 5 to 8

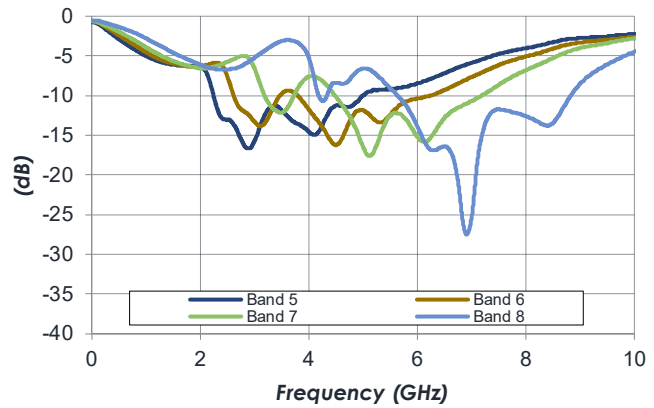

Return Loss | Bands 9 to 12

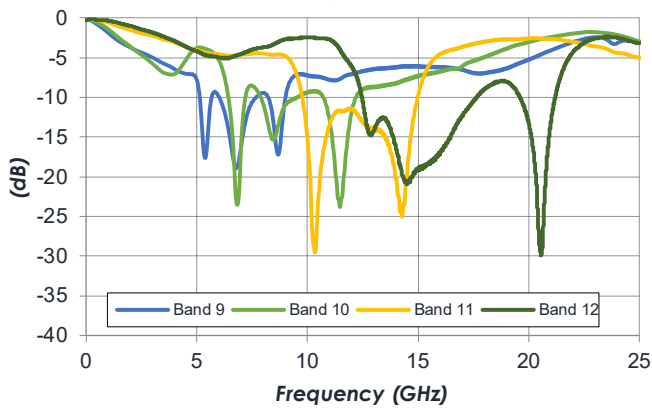

Bypass Path

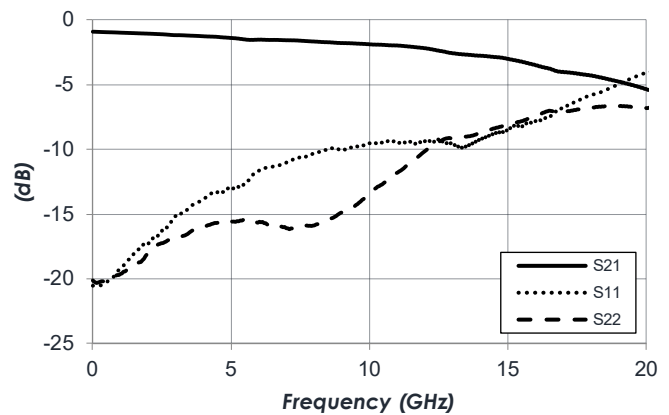

TYPICAL PERFORMANCE (CONTINUED)

(VDD = +5.0V, VAmp = +3.3V, T = 25°C unless otherwise specified)

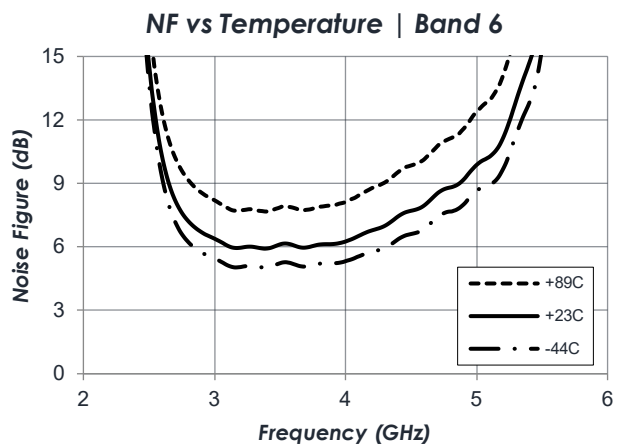
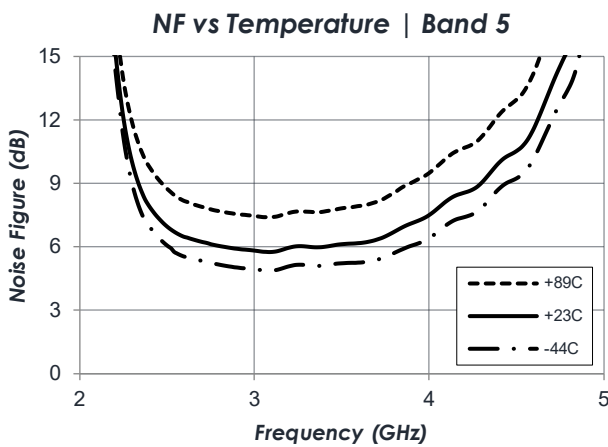
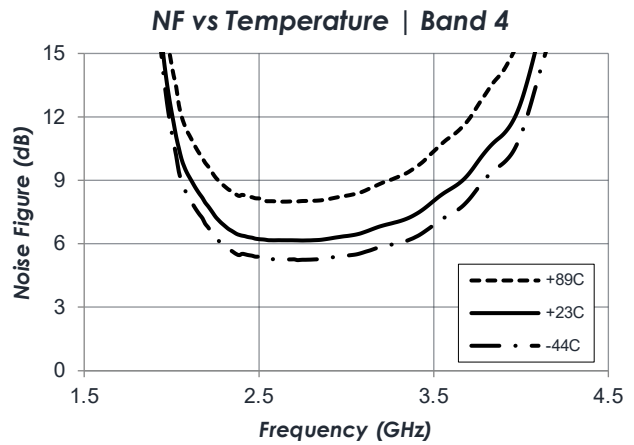
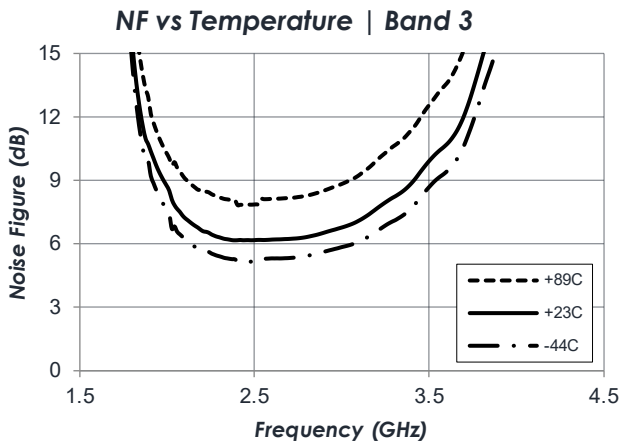
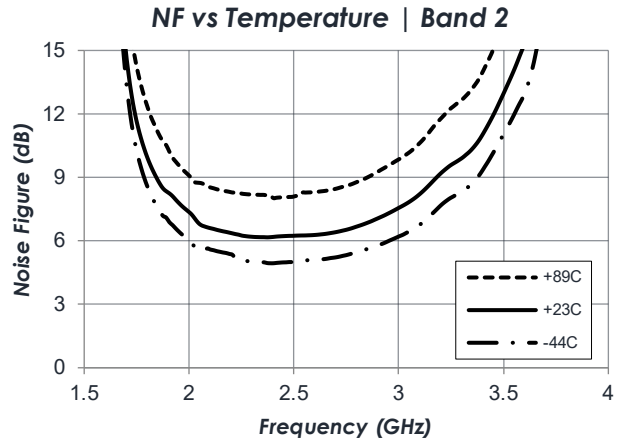
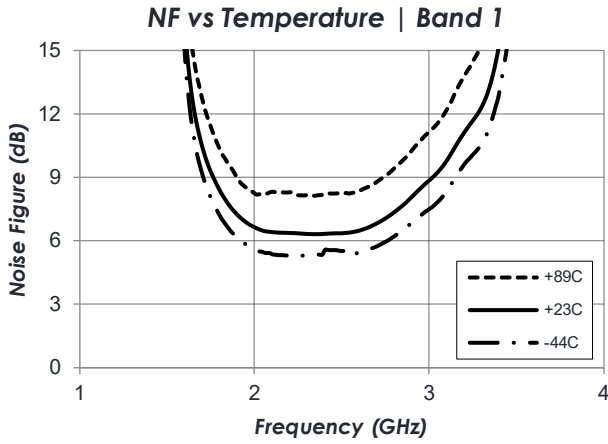

TYPICAL PERFORMANCE (CONTINUED)

(VDD = +5.0V, VAmp = +3.3V, T = 25°C unless otherwise specified)

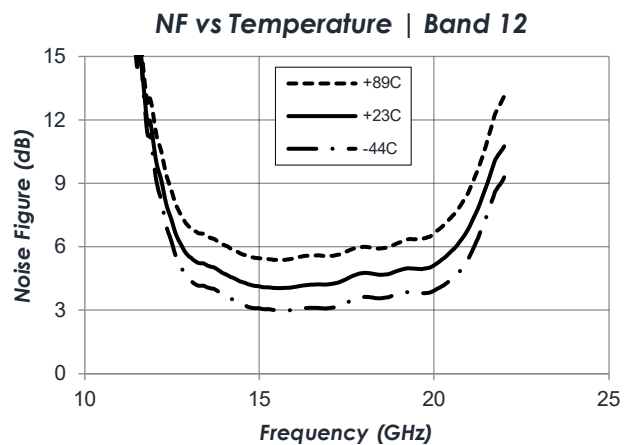
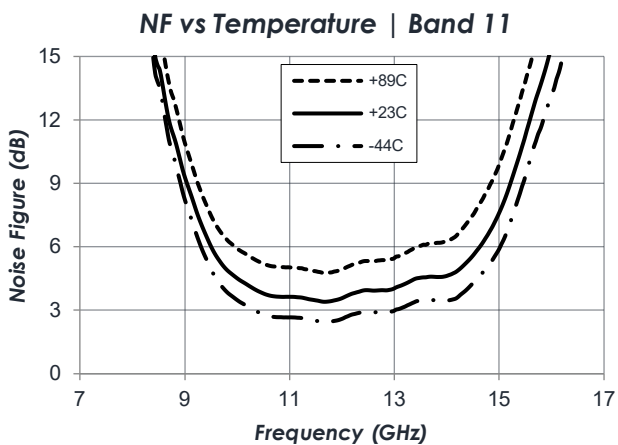
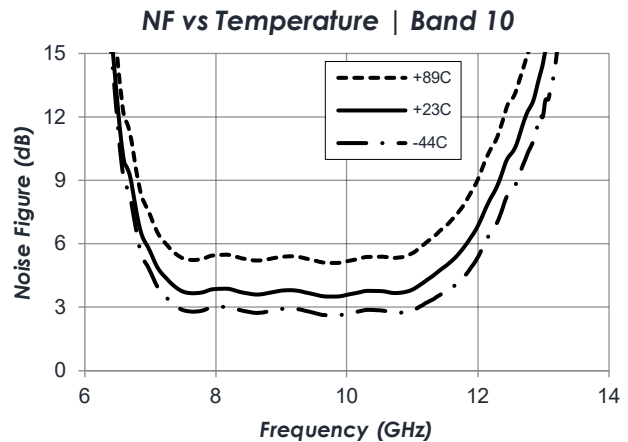
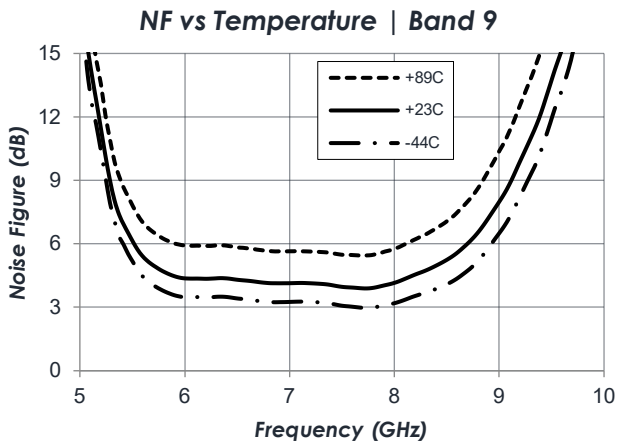
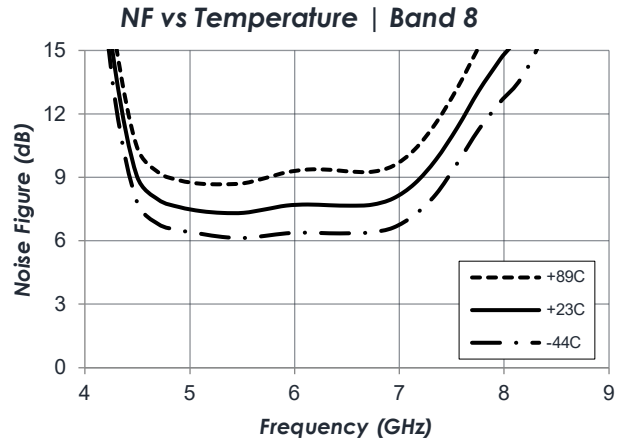
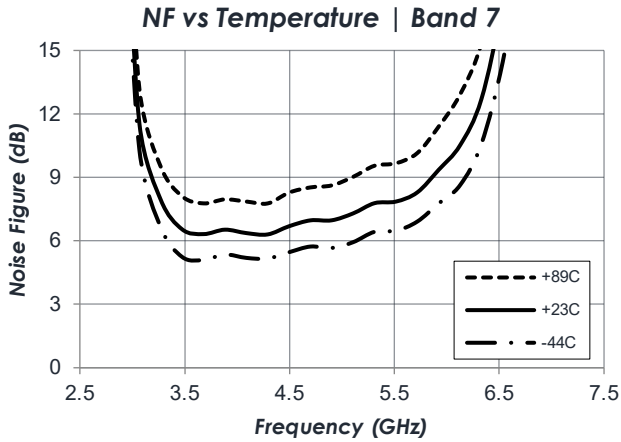

TYPICAL PERFORMANCE (CONTINUED)

(VDD = +5.0V, VAmp = +3.3V, T = 25°C unless otherwise specified)

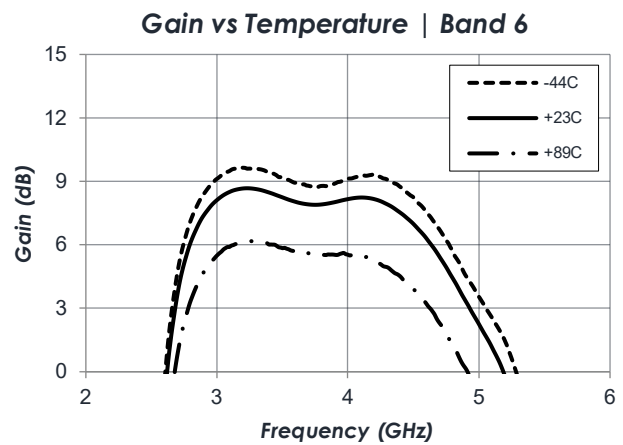
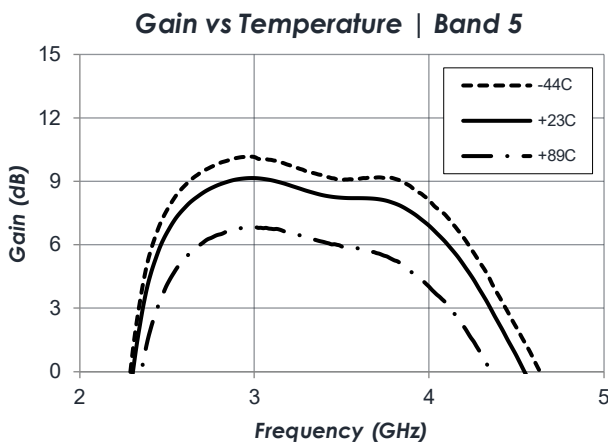
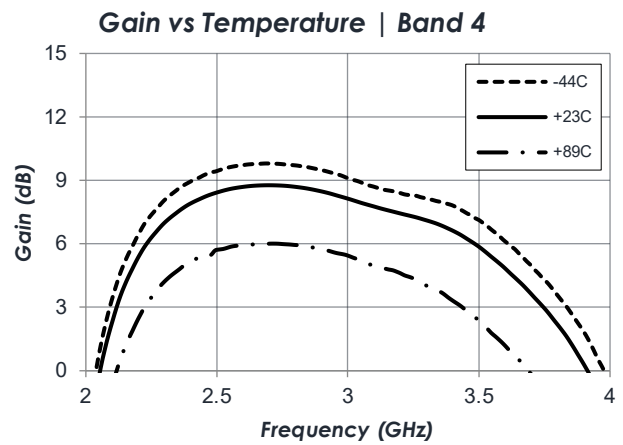
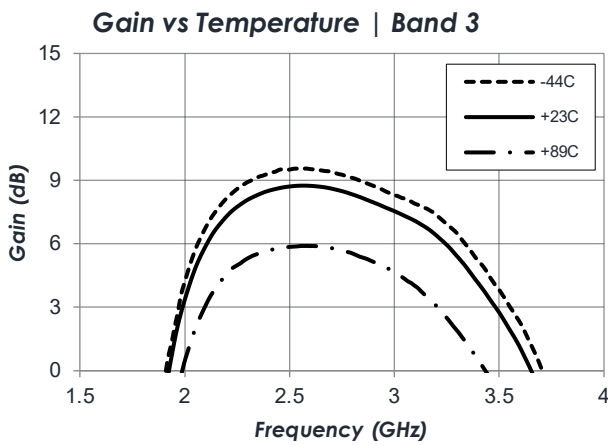
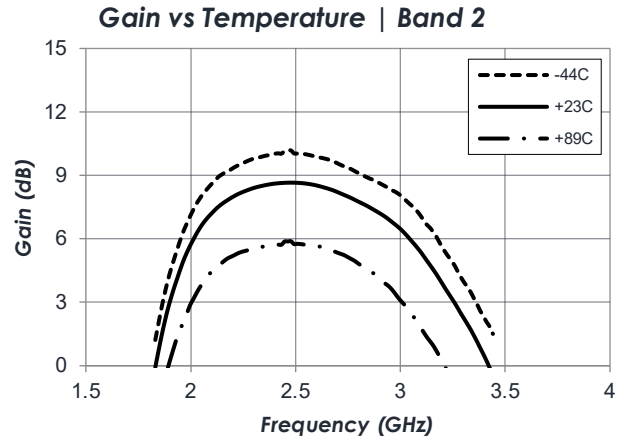
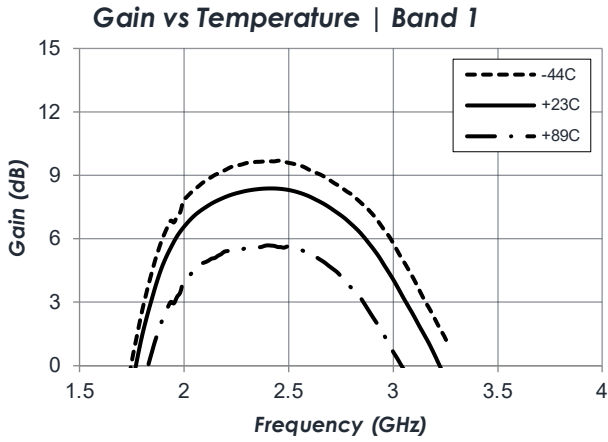

TYPICAL PERFORMANCE (CONTINUED)

(VDD = +5.0V, VAmp = +3.3V, T = 25°C unless otherwise specified)

Gain vs Temperature | Band 7

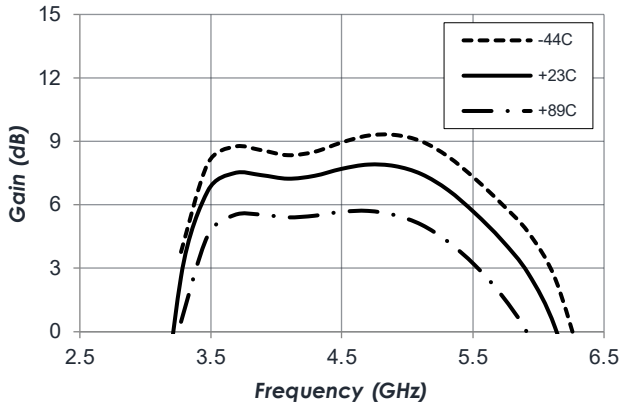

Gain vs Temperature | Band 8

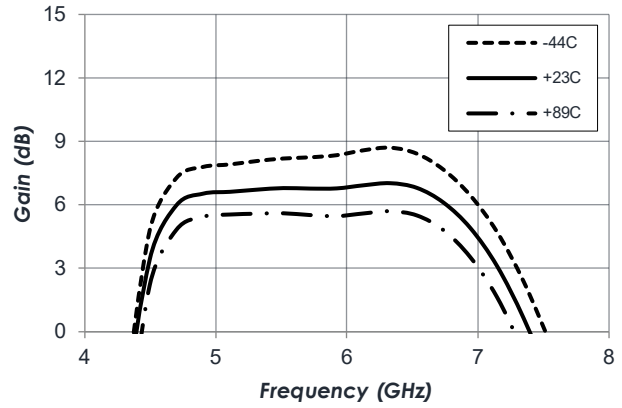

Gain vs Temperature | Band 9

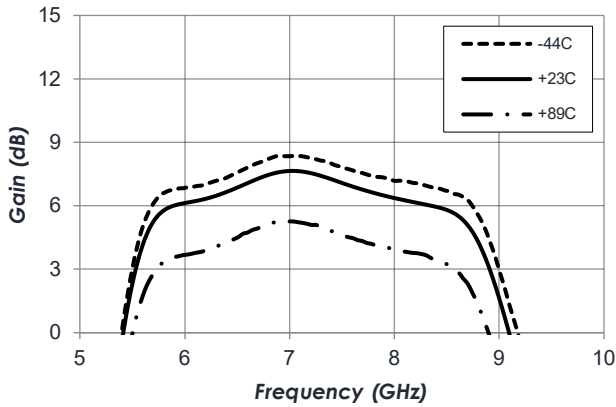

Gain vs Temperature | Band 10

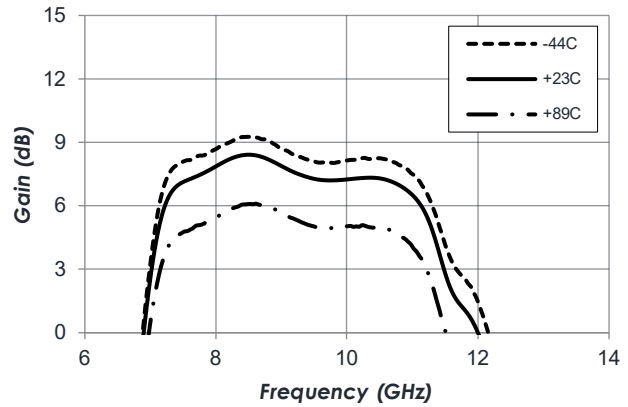

Gain vs Temperature | Band 11

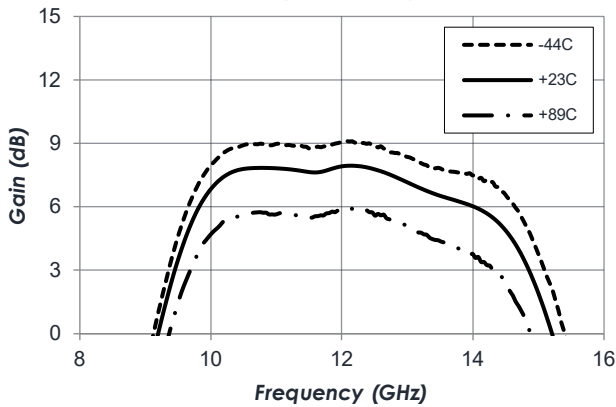

Gain vs Temperature | Band 12

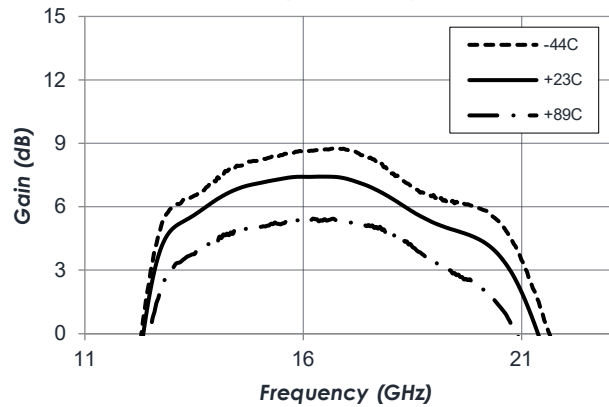

TYPICAL APPLICATION

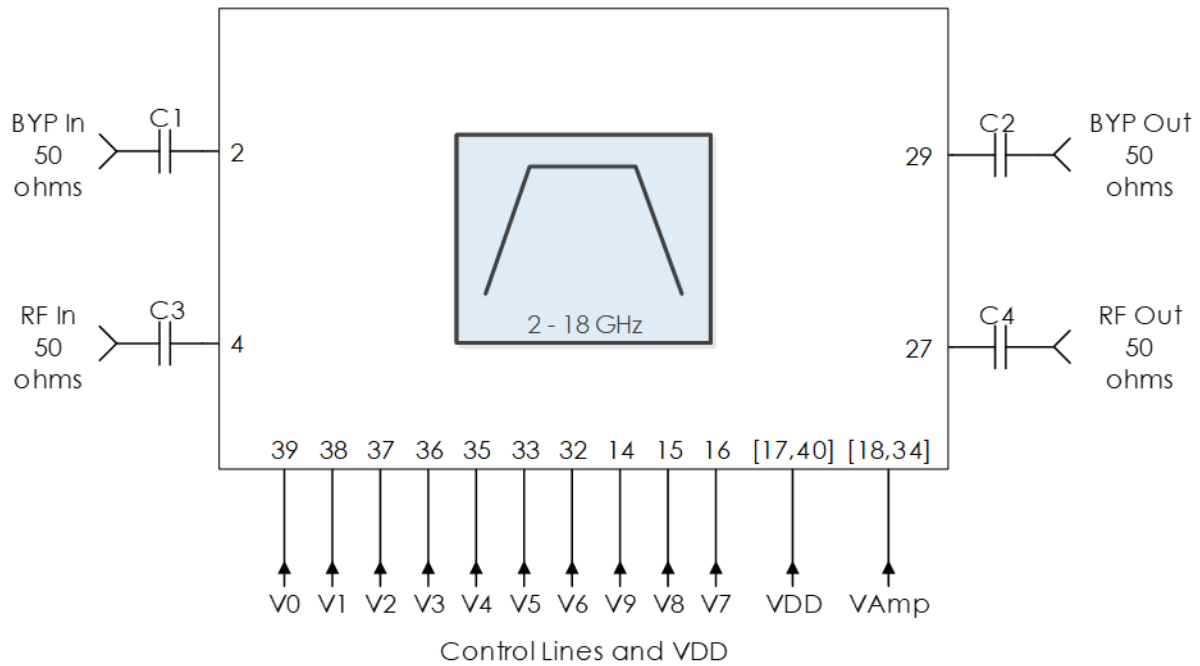

Recommended Component List (or Equivalent)

Part	Value	Part Number	Manufacturer
C1, C2, C3, C4	0.1uF	0201BB104KW160	Passives Plus

Notes:

1. VDD and control lines are filtered internally, providing high frequency isolation.
2. DC blocking capacitors should be low-loss, broadband capacitors for optimum performance.

EVALUATION PC BOARD

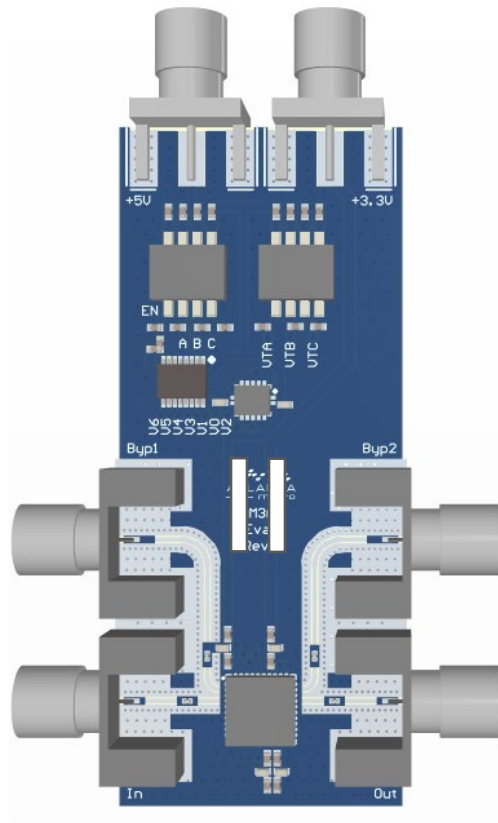

RELATED PARTS

Part Number		Description
AM3025A	400 MHz to 6 GHz	Sub-Octave Filter Bank
AM3156	400 MHz to 8 GHz	Digitally Tunable Bandpass
AM3043	6.5 GHz to 17 GHz	Digitally Tunable Bandpass
AM3063	6 GHz to 18 GHz	Digitally Tunable Bandpass
AM3089	2 GHz to 18 GHz	Analog Tunable Switched Bandpass Bank
AM3136	8 GHz to 19 GHz	Analog Tunable Switched Bandpass Bank

**Evaluation PC Board State Table**

EN	A	B	C	VTA	VTB	VTC	State
0	x	x	x	x	x	x	Disabled
1	1	0	0	x	x	x	Bypass
1	1	0	1	0	0	0	Band 1
1	1	0	1	1	0	0	Band 2
1	1	0	1	0	1	0	Band 3
1	1	0	1	1	1	0	Band 4
1	1	0	1	0	0	1	Band 5
1	1	0	1	1	0	1	Band 6
1	1	0	1	0	1	1	Band 7
1	1	0	1	1	1	1	Band 8
1	0	1	1	x	x	x	Band 9
1	0	1	0	x	x	x	Band 10
1	0	0	1	x	x	x	Band 11

COMPONENT COMPLIANCE INFORMATION

**RoHS:** Mercury Systems, Inc. hereby certifies that all products comply with the EC Directive 2011/65/EC on the Restriction of Hazardous Substances, commonly known as EU-RoHS 6 and 10. All products supplied by Mercury shall be compliant with the European Directive 2011/65/EC based on the following substance list.

Substance List	Allowable Maximum Concentration
Lead (Pb)	<1000 PPM (0.1% by weight)
Mercury (Hg)	<1000 PPM (0.1% by weight)
Cadmium (Cd)	<75 PPM (0.0075% by weight)
Hexavalent Chromium (CrVI)	<1000 PPM (0.1% by weight)
Polybrominated Biphenyls (PBB)	<1000 PPM (0.1% by weight)
Polybrominated Diphenyl ethers (PBDE)	<1000 PPM (0.1% by weight)
Decabromodiphenyl Deca BDE	<1000 PPM (0.1% by weight)
Bis (2-ethylhexyl) Phthalate (DEHP)	<1000 PPM (0.1% by weight)
Butyl Benzyl Phthalate (BBP)	<1000 PPM (0.1% by weight)
Dibutyl Phthalate (DBP)	<1000 PPM (0.1% by weight)
Diisobutyl Phthalate (DIBP)	<1000 PPM (0.1% by weight)

**REACH:** Mercury Systems, Inc. neither uses nor intentionally adds any of the substances considered to be a Substance of Very High Concern (SVHC) as defined by the EU Regulation (EC) No. 1907-2006 on Registration, Evaluation, Authorization, and Restriction of Chemicals (REACH).

**Conflict Materials:** Mercury does not knowingly use materials that are sourced from the Democratic Republic of Congo (DRC) or any other known conflict regions. Mercury’s supply chain is comprised of sources that are both environmentally and socially responsible. We periodically review this requirement with our vendors to ensure continued compliance.

**Mercury takes its responsibility as a global partner seriously and will use due diligence within our supply chain to ensure all standards are met to the best of our knowledge.**



**Corporate Headquarters**

50 Minuteman Road  
 Andover, MA 01810 USA  
 +1 978.967.1401 tel  
 +1 866.627.6951 tel  
 +1 978.256.3599 fax

**International Headquarters  
 Mercury International**

Avenue Eugène-Lance, 38  
 PO Box 584  
 CH-1212 Grand-Lancy 1  
 Geneva, Switzerland  
 +41 22 884 5100 tel

**Learn more**

**Visit:** [mrcy.com](http://mrcy.com)

For pricing details, contact: [MMICsales@mrcy.com](mailto:MMICsales@mrcy.com)

For technical details, contact: [MMICsupport@mrcy.com](mailto:MMICsupport@mrcy.com)



The Mercury Systems logo is a registered trademark of Mercury Systems, Inc. Other marks used herein may be trademarks or registered trademarks of their respective holders. Mercury products identified in this document conform with the specifications and standards described herein. Conformance to any such standards is based solely on Mercury’s internal processes and methods. The information contained in this document is subject to change at any time without notice.

