

AM9058 – Upconverter

0.9 GHz to 18 GHz Wideband Upconverter Module

High performance and low SWaP (size, weight and power)

- Fully integrated upconverter module provides high dynamic range coverage from 0.9 to 18 GHz
- Also provides a bypass path from 10 MHz to 3 GHz for direct spectrum transmission
- Multiple channels can be configured to work together for coherent operation and N-channel applications

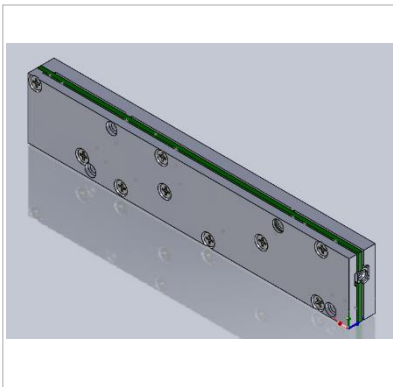

AM9058 is a fully integrated upconverter module that provides high dynamic range coverage from 0.9 GHz to 18 GHz. The upconverter also provides a bypass path from 10 MHz to 3 GHz for direct spectrum transmission. The heterodyne architecture is designed for high performance and low size, weight, and power (low SWaP) and is mechanically mountable to a host circuit board for use in multi-channel transmit applications.

Sub-octave postselector filters, driver amplifiers, local oscillators, frequency converters, power and control line filtering, temperature sensor, and a control FPGA are included. The analog IF input frequency is centered at 2 GHz with a 1 GHz instantaneous bandwidth. Multiple channels can be configured to work together for coherent operation and N-channel applications. Interfacing to the upconverter is accomplished by simply providing an IF input, DC voltages, frequency reference, SPI control, and connecting the RF output. The module is designed to work either as a standalone unit or to stack on top of an AM9057 to create a single channel Rx/single channel Tx module stack.

FEATURES

- 0.9 GHz to 18 GHz Frequency Range
- 1-GHz Instantaneous Bandwidth
- 2 GHz IF center Frequency
- 10 MHz to 3 GHz Tuner Bypass Path
- Sub-Octave Output Filter
- Integrated Temperature Sensor
- 6 dB Gain
- Up to +10 dBm Output Power
- +20 dBm OIP3
- +80 dBc Second Harmonic
- +5.0V and +3.3V DC Operation
- 5.5 W Max Power Consumption
- -40C to +85C Operation
- 4" x 0.75" x 0.38" (101.6 x 19.05 x 9.6 mm)

CONTENTS

FEATURES 1

REVISION HISTORY..... 2

PART ORDERING DETAILS 3

SPECIFICATIONS..... 3

MECHANICAL DETAILS..... 5

AM9057/AM9058 EVAL BOARD 8

MULTIPLE MODULE CONFIGURATIONS 9

REVISION HISTORY

Date	Revision	Notes
May 4, 2026	1.0	Initial Release

PART ORDERING DETAILS

Part Number	Description
AM9058	Stand-alone Tx Module, 2.0 GHz IF Input w/ 1 GHz Bandwidth
AM9057	Stand-alone Rx Module, 2.0 GHz IF Output w/ 1 GHz Bandwidth
AM9059	2-Channel Stacked Downconvert Modules, Consists of two AM9057s
AM9060	2-Channel Stacked Up/Downconvert Modules, Consists of one AM9057 and one AM9058
AM9057_58-EVAL-ABXY	AM9057/58 Eval Board with one slot occupied with a stack of A (1-2) AM9057s and B (0 or 1) AM9058s and the second slot occupied with a stack of X AM9057s (0-2) and Y AM9058s (0-1). For example, an eval board with a 9057/58 stack in the first slot and AM9058 in the second slot has the part number AM9057_58-EVAL-1101

Note: Eval boards include low-dropout regulators, reference distribution circuitry, and control circuitry. All that is required for operation is an input signal, a reference, and a Windows computer for the USB control of the evaluation board. See "Evaluation PC Board" section for more details. The output may be driven into a spectrum analyzer or into an antenna. Contact Mercury for ADC recommendations.

SPECIFICATIONS

Absolute Maximum Ratings

	Test Cond	Minimum	Maximum
RF Input Power	Continuous Wave		0.25 W
+5.0 VDC Supply			+5.5 V
+3.3 VDC Supply			+3.6 V
Operating Temperature		-40 C	+85 C
Storage Temperature Range		-55 C	+150 C

Note: Any device operation beyond the Absolute Maximum Ratings may result in permanent damage to the device. The values listed in this table are extremes and do not imply functional operation of the device at these or any other conditions beyond what is listed under Recommended Operating Conditions. Any part subjected to conditions outside of what is recommended for an extended amount of time may suffer from reliability concerns.

Handling Information

	Minimum	Maximum
Storage Temperature Range (Recommended)	-50 C	+125 C



Mercury products are electrostatic sensitive. Follow safe handling practices to avoid damage.

Recommended Operating Conditions

	Minimum	Typical	Maximum
Operating Case Temperature	-35 C		+71 C

DC Electrical Characteristics

(T = 25 °C unless otherwise specified)

Param	Testing Conditions	Min	Typical	Max
+5 VDC Supply		+4.8 V	+5.0 V	+5.2 V
+3.3 VDC Supply		+3.2 V	+3.3 V	+3.5 V
+5 VDC Current				0.42 A
+3.3 VDC Current				1.1 A
Power Dissipated				5.5 W
Logic Level Low		0 V		+0.8 V
Logic Level High		+2.0 V		+3.5 V

RF Performance¹

(T = 25 °C unless otherwise specified)

Param	Testing Conditions	Min	Typical	Max
Frequency Range	Heterodyne Path	0.9 GHz		18 GHz
	Bypass Path	10 MHz		3 GHz
Instantaneous Bandwidth			1.0 GHz	
IF Center Frequency			2.0 GHz	
Tune Frequency Range		1.4 GHz		17.5 GHz
Tuning Step Size			5 MHz	
Frequency Reference	External 100 MHz (note 3)	-2dBm (0.5Vpp)	+6dBm	+13.5dBm (3Vpp)
Output IP3			+20 dBm	
Output Second Harmonic			70 dBc	
Output P1dB			10 dBm	
Image Rejection		70 dB		
IF Rejection	Stopband Relative to Passband	50 dB	60 dB	
LO Radiation	Measured at RF Output		-80 dBm	-50 dBm
Gain	Measured at Tune Freq.		6 dB +/-2dB	
Gain Control ¹			16 dB	
Tuning Speed			100 μs	450 μs ²
Phase Noise	1 kHz Offset		-90 dBc/Hz	
	10 kHz Offset		-100 dBc/Hz	
	100 kHz Offset		-100 dBc/Hz	
	1 MHz Offset		-106 dBc/Hz	
	10 MHz Offset		-127 dBc/Hz	

Note 1: Additional gain control beyond calibrated gain, in 1 dB steps. Heterodyne path only.

Note 2: Longest tune speed is seen when switching from $F_c \leq 5500$ to $F_c > 5500$ or from $F_c > 5500$ to $F_c \leq 5500$. Switching between center frequencies in either $F_c \leq 5500$ range or $F_c > 5500$ range will follow typical tuning speed.

Note 3: External reference input impedance is 50 ohms. Tolerant of sine wave or square wave input. Reference waveform may affect spurious and phase noise performance.

MECHANICAL DETAILS

Connector and Pin Definitions

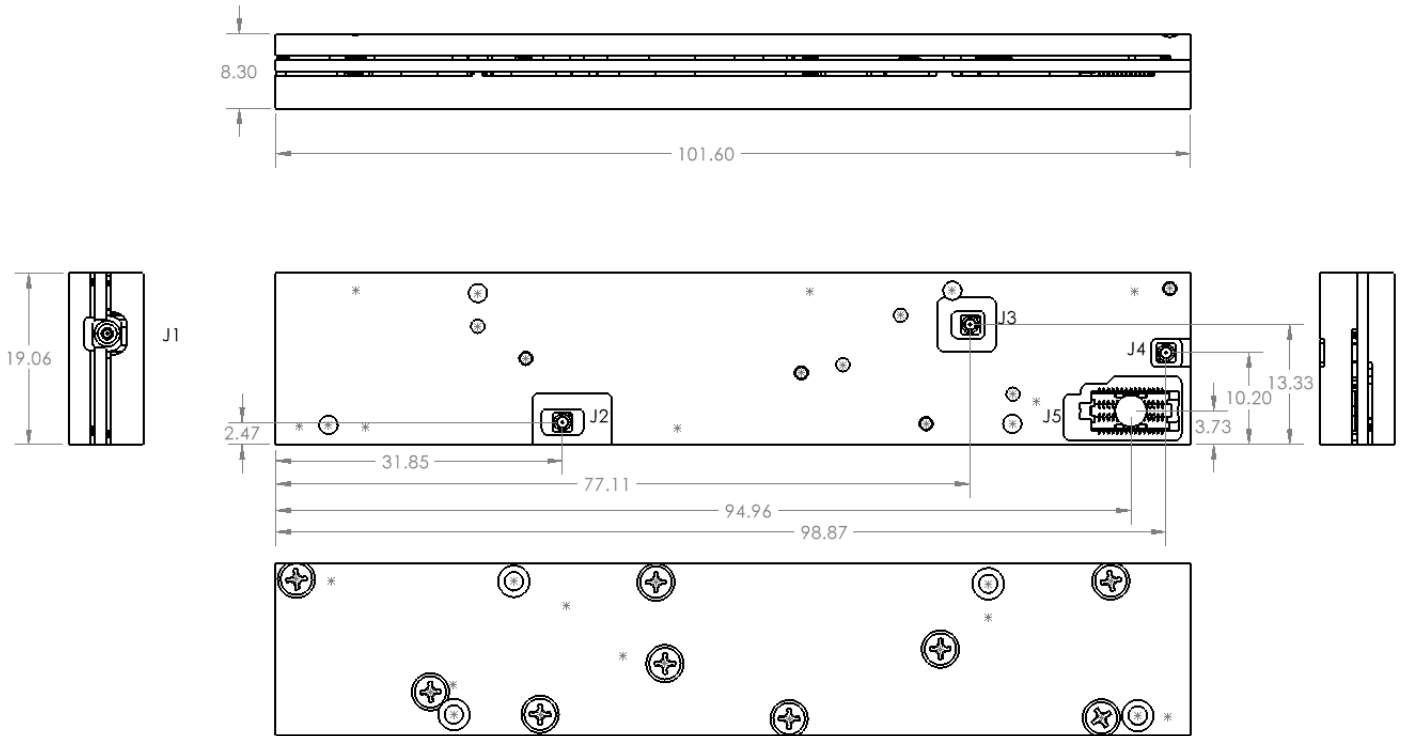

Connector	Name	Function
J1	TX Out	10 MHz to 18 GHz Output, AC-Coupled
J2	Ext LO In 1	9 - 21 GHz LO Input. Only needed in shared LO mode when in a 2 module stacked configuration.
J3	Ext LO In 2	5 - 8 GHz LO Input. Only needed in shared LO mode when in a 2 module stacked configuration
J4	IF Out	2 GHz center with 1GHz BW IF Output
J5	Multipin Connector	Connector for 100 MHz reference input, SPI interface, and power for both this module and a potential daughter card.

PCB Locations of Screw Holes and Connectors

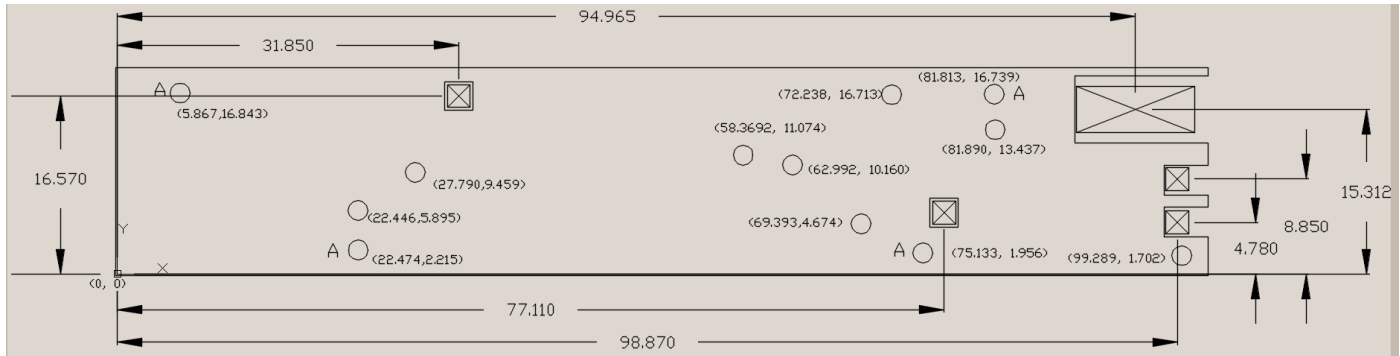

All Dimensions in mm.

Screw locations marked "A" are for module stacking use only. A clearance hole on the carrier board must be in these locations.

All unlabeled screw locations are #1-72 threaded holes with a depth of 0.06"

Module Solder Mask Relief

This drawing shows the area where solder mask should be relieved. It is a minimum of 0.127 mm (5 mils) outside of the physical module dimensions.

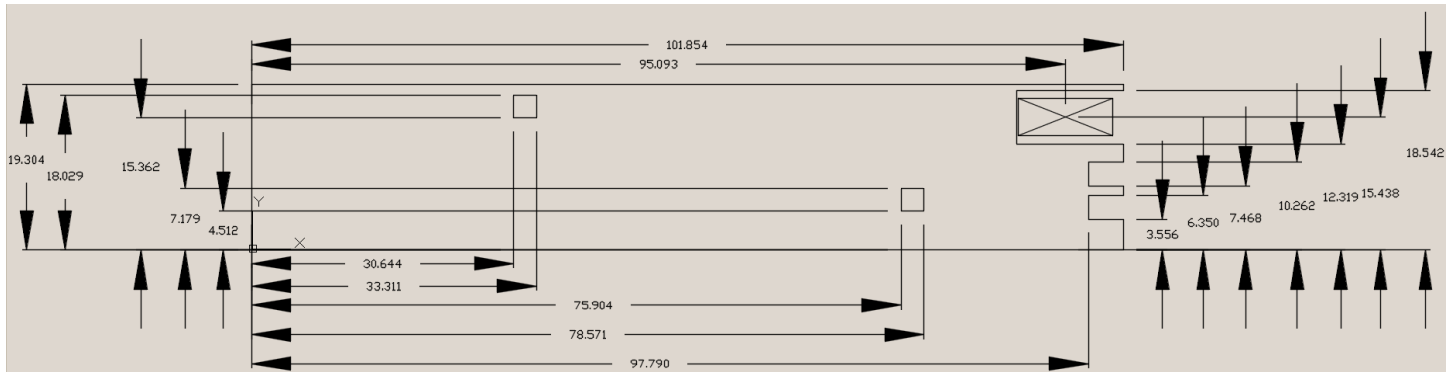

All dimensions in mm.

Mating Connector List

Connector	Mating Connector Part Number	Manufacturer
J1	SMPM bullet	COTS SMPM bullet or cable assembly
J2-J4	55057-006J 54033-004B	Southwest Microwave full detent connector and bullet
J5	ST5-15-1.00-L-D-P-TR	Samtec

J5 Pinout

Pin	Pin Name	Pin Function
1,2,4,5,6,17, 18, 26, 30	GND	Ground connections
3	Reference Input	100 MHz single ended 50 ohm Reference Input for this module. -2 to +10 dBm
7, 9	+3.3V In Tuner 1	+3.3V Input Pin for this module, allowable input range +3.2V to +3.5V. Max current 1.3A
8	+5.0V In Tuner 1	+5.0V Input Pin for this module, allowable input range +4.8V to +5.2V. Max current 0.5A
10	SPI Clock Tuner 1	Clock input pin for SPI interface for this module
11	POP	Power On Pin, soft reset line for the tuner FPGA. Holding this line low holds the FPGA in reset. Resets both this module and the module mated with it if present.
12	SPI MISO Tuner 1	MISO pin for SPI interface for this module
13	CMD_CS _n Tuner 1	Chip select line for SPI interface used to send configuration commands to this module.
14	SPI MOSI Tuner 1	MOSI line for SPI interface for this module
15	PROG_CS _n Tuner 1	Chip select line for SPI interface used to send commands accessing core FPGA functionality for this module.
16	LO_SYNC Tuner 1	LO Sync line for this module. This is used as a trigger to allow multiple modules to maintain a consistent phase relationship at a given frequency.
17	Lock Detect Tuner 1	Lock detect signal for this tuner. Indicates lock status of the main tuning LO
19	+5.0V In Tuner 2	+5.0V Input Pin for the mated module (if applicable), allowable input range +4.8V to +5.2V. Max current 0.5A
20	SPI Clock Tuner 2	Clock input pin for SPI interface for the mated module (if applicable)
21	CMD_CS _n Tuner 2	Chip select line for SPI interface used to send configuration commands to the mated module (if applicable).
22	MISO Tuner 2	MISO line for SPI interface to the mated module (if applicable).
23	PROG_CS _n Tuner 2	Chip select line for SPI interface used to send commands accessing core FPGA functionality for the mated module (if applicable).
24	MOSI Tuner 2	MOSI line for SPI interface for the mated module (if applicable).
25	Lock Detect Tuner 2	Lock detect signal for this tuner. Indicates lock status of the main tuning LO
27, 29	+3.3V In Tuner 2	+3.3V Input Pin for the mated module (if applicable), allowable input range +3.2V to +3.5V. Max current 1.3A
28	REF In Tuner 2	100 MHz single ended 50 ohm Reference Input for the mated module (if applicable). -2 to +10 dBm

AM9057/AM9058 EVAL BOARD

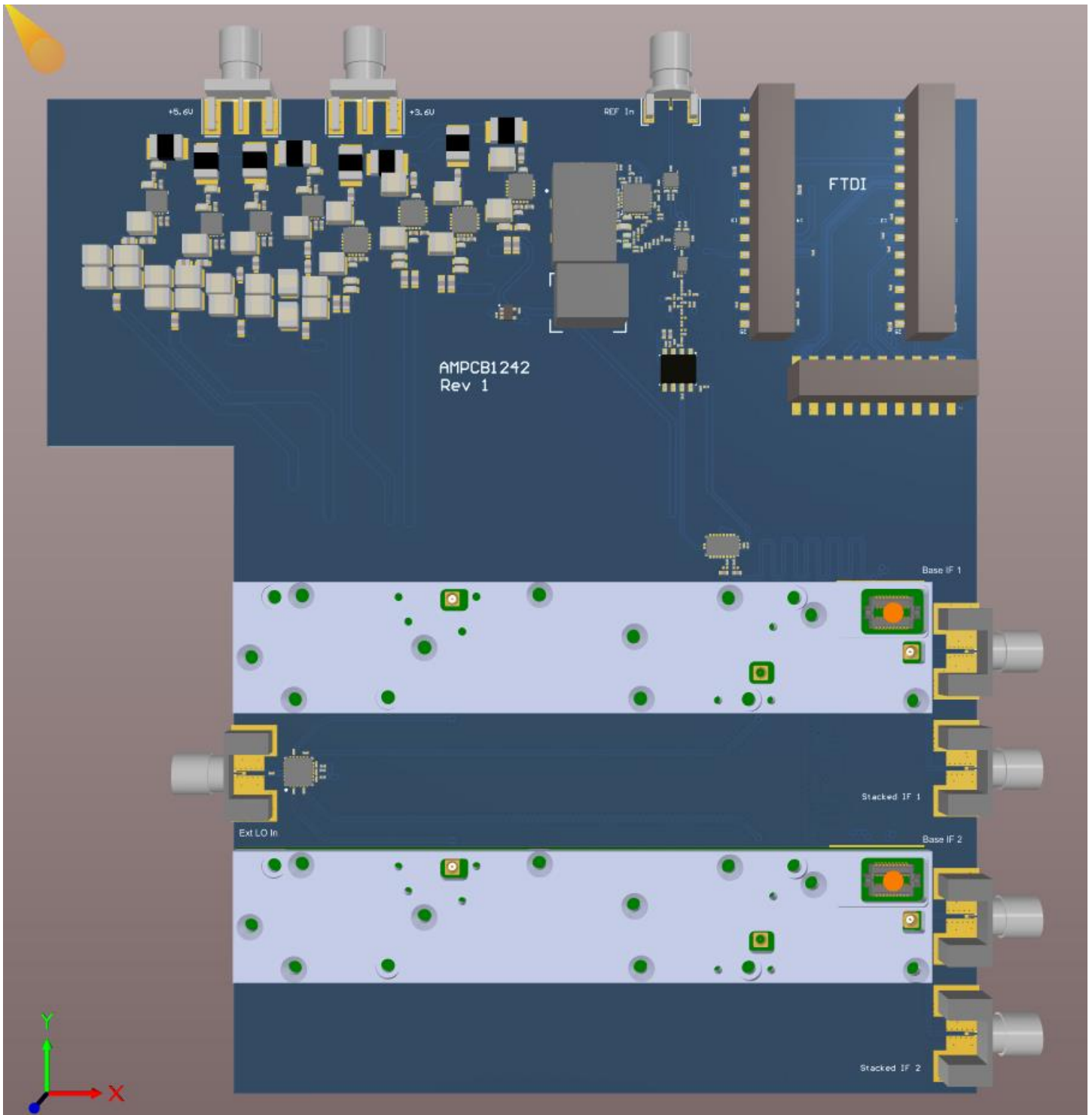

MULTIPLE MODULE CONFIGURATIONS

1 Rx and 1 Tx Module (AM9060)

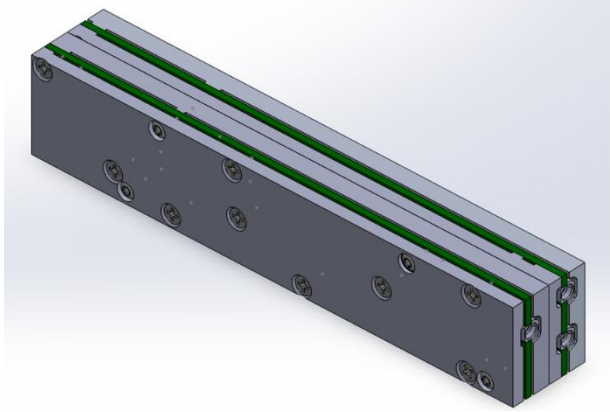

Corporate Headquarters

50 Minuteman Road
Andover, MA 01810 USA
+1 978.967.1401 tel
+1 866.627.6951 tel
+1 978.256.3599 fax

International Headquarters

Mercury International
Avenue Eugène-Lance, 38
PO Box 584
CH-1212 Grand-Lancy 1
Geneva, Switzerland
+41 22 884 5100 tel

Learn more

Visit: mrcy.com

For pricing details, contact: MMICsales@mrcy.com

For technical details, contact: MMICsupport@mrcy.com



The Mercury Systems logo is a registered trademark of Mercury Systems, Inc. Other marks used herein may be trademarks or registered trademarks of their respective holders. Mercury products identified in this document conform with the specifications and standards described herein. Conformance to any such standards is based solely on Mercury's internal processes and methods. The information contained in this document is subject to change at any time without notice.



© 2025 Mercury Systems, Inc. 1-0-2026-05-04-DS-AM9058