

AM1084 – Amplifier

DC to 6 GHz Gain Block

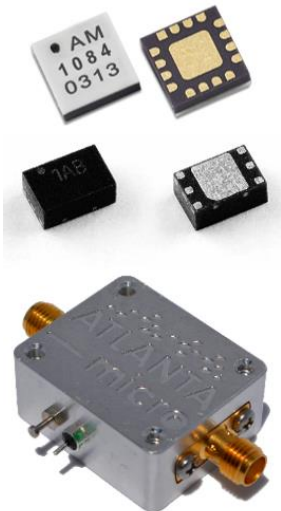

The AM1084 is a DC-coupled amplifier covering up to 6 GHz. The device exhibits high second and third order intercept performance, excellent gain stability over the operating temperature range, and a moderate positive gain slope providing frequency equalization useful in many broadband applications. With internal 50Ω matching and packaged in a 3mm QFN or 1.3mm x 2mm DFN, the AM1084 represents a compact total PCB footprint.

FEATURES

- 16 dB Gain
- 2.3 dB Noise Figure
- +37 dBm OIP3
- +48 dBm OIP2
- +21 dBm P1dB
- +3.3V, 69 mA or +5.0V, 112 mA
- 1.3mm x 2mm DFN or 3mm QFN
- -40C to +85C Operation
- Available in RF Shielded Module

FUNCTIONAL DIAGRAM

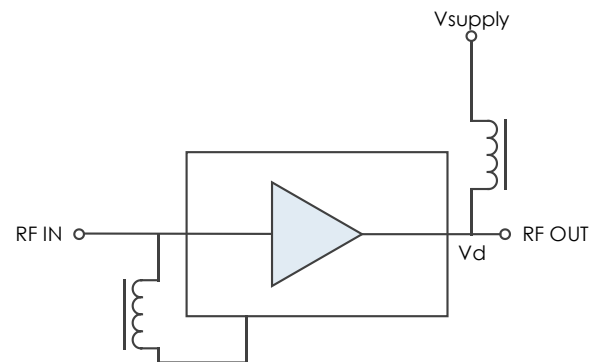

CHARACTERISTIC PERFORMANCE

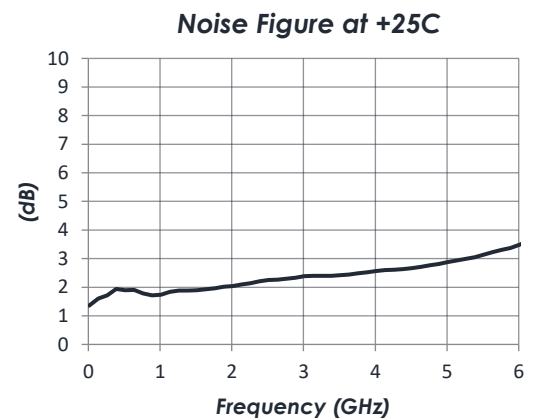
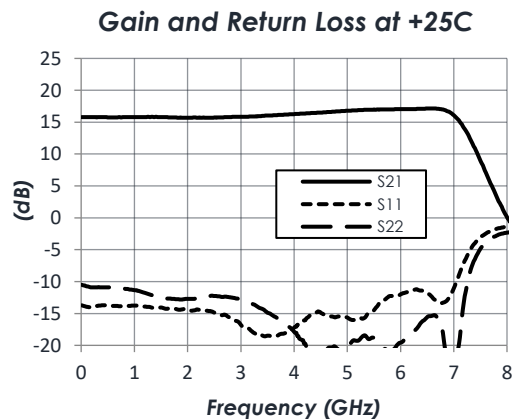

CONTENTS

FEATURES 1

FUNCTIONAL DIAGRAM 1

CHARACTERISTIC PERFORMANCE 1

REVISION HISTORY..... 2

PIN LAYOUT AND DEFINITIONS 3

SPECIFICATIONS..... 5

TYPICAL PERFORMANCE 7

TYPICAL APPLICATION..... 10

EVALUATION PC BOARD..... 11

PART ORDERING DETAILS 11

RELATED PARTS 12

COMPONENT COMPLIANCE INFORMATION 13

REVISION HISTORY

Date	Revision	Notes
January 8, 2020	1	Initial Release
November 11, 2020	2	Package and Module information moved to main product page on website.
November 7, 2024	3	Changed to Mercury branding. No content changes.
September 17, 2025	4	Updated image for Eval Board Rev2

PIN LAYOUT AND DEFINITIONS

AM1084-1: 3mm QFN

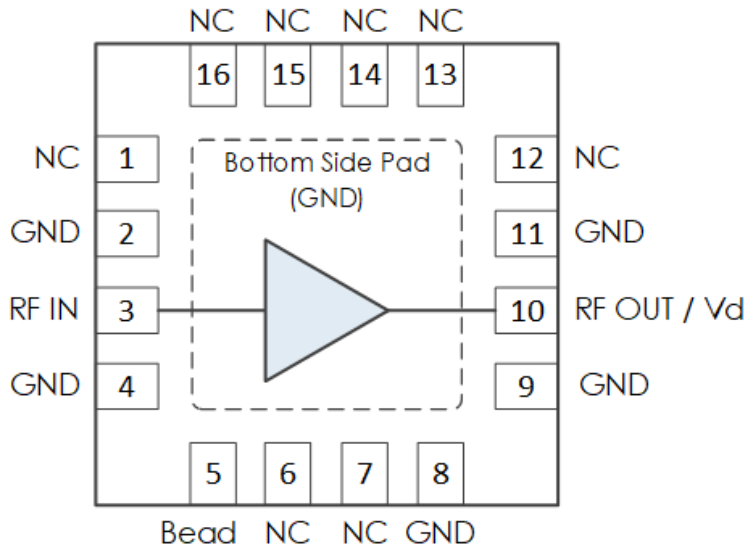

Pin	Name	Function
1	NC	Not Connected *
2	GND	Ground - Common
3	RF IN	RF Input - 50 ohms - DC Coupled, External DC Block Required
4	GND	Ground - Common
5	Bead	Connect to RF In through external ferrite bead or large inductor
6, 7	NC	Not Connected *
8, 9	GND	Ground - Common
10	RF Out / Vd	RF Output - 50 Ohms - DC Coupled. External DC Blocking Capacitor Required
11	GND	Ground - Common
12-16	NC	Not Connected *

* NC pins may be grounded or left open.

PIN LAYOUT AND DEFINITIONS (CONTINUED)

AM1084-2: 1.3mm x 2mm DFN

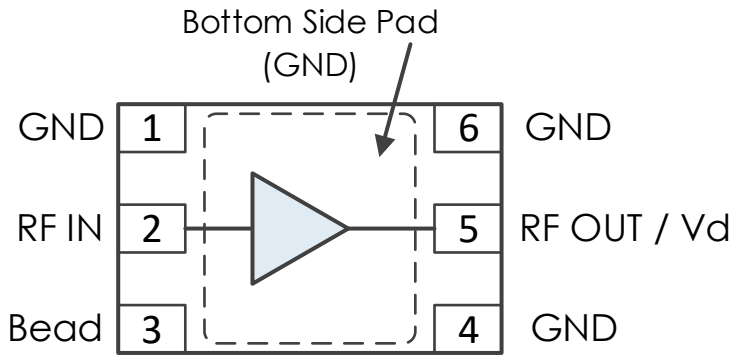

Pin	Name	Function
1	GND	Ground - Common
2	RF IN	RF Input - 50 ohms - DC Coupled, External DC Block Required
3	Bead	Connect to RF In through external ferrite bead or large inductor
4	GND	Ground - Common
5	RF Out / Vd	RF Output - 50 Ohms - DC Coupled. External DC Blocking Capacitor Required
6	GND	Ground - Common

SPECIFICATIONS

Absolute Maximum Ratings

	Minimum	Maximum
Supply Voltage	-0.3 V	+6.0 V
RF Input Power		+20 dBm
Operating Junction Temperature	-40 C	+150 C
Storage Temperature Range	-50C	+150 C

Note: Any device operation beyond the Absolute Maximum Ratings may result in permanent damage to the device. The values listed in this table are extremes and do not imply functional operation of the device at these or any other conditions beyond what is listed under Recommended Operating Conditions. Devices subjected to conditions outside of what is recommended for extended periods may affect device reliability.

Handling Information

	Minimum	Maximum
Storage Temperature Range (Recommended)	-50 C	+125 C
Moisture Sensitivity Level	MSL 1	



Mercury products are electrostatic sensitive. Follow safe handling practices to avoid damage.

Recommended Operating Conditions

	Minimum	Typical	Maximum
Supply Voltage	+2.7 V	+5.0 V	+5.2 V
Operating Case Temperature	-40 C		+85 C
Operating Junction Temperature	-40 C		+125 C

Thermal Information

Thermal Resistance (°C / W)	
Junction to Case Thermal Resistance (θ_{JC})	32

DC Electrical Characteristics

(T = 25 °C unless otherwise specified)

Param	Testing Conditions	Min	Typical	Max
DC Supply Voltage		+2.7 V	+5.0 V	+5.2 V
DC Supply Current	VD = +3.3 V		69 mA	
	VD = +5.0 V		112 mA	
Power Dissipated	VD = +3.3 V		0.23 W	
	VD = +5.0 V		0.56 W	

RF Performance

(T = 25 °C unless otherwise specified)

Param	Testing Conditions	Min	Typical	Max
Frequency Range		DC		6 GHz
Gain	VD = +5.0 V		16 dB	
Return Loss	VD = +5.0 V		15 dB	
Output IP3	VD = +5.0 V		37 dBm	
Output IP2	VD = +5.0 V		48 dBm	
Output P1dB	VD = +5.0 V		21 dBm	
Output PSat	VD = +5.0 V		21.5 dBm	
Noise Figure	VD = +5.0 V		2.3 dB	

TYPICAL PERFORMANCE

(VD = +5.0 V, Id = 112 mA)

Gain vs Temperature

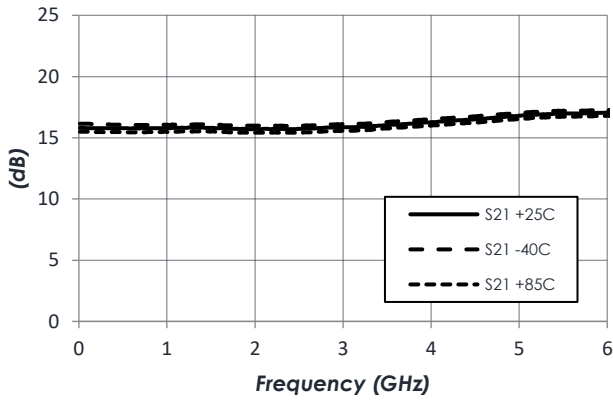

Noise Figure vs Temperature

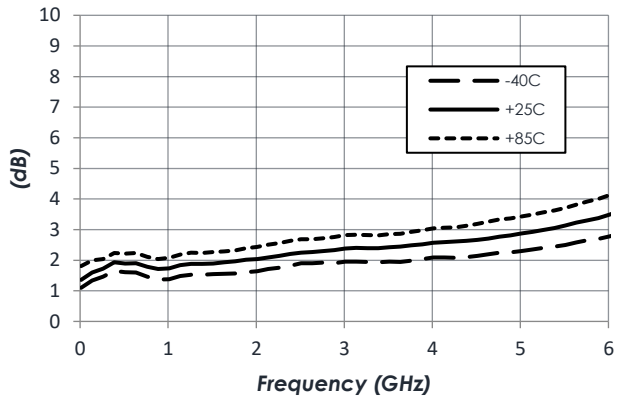

Output IP3 vs Temperature*

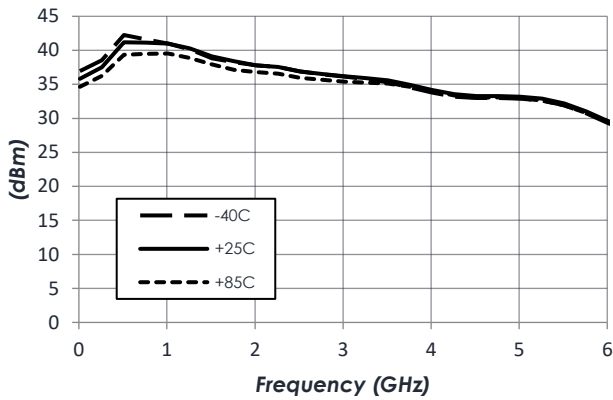

Output IP2 vs Temperature*

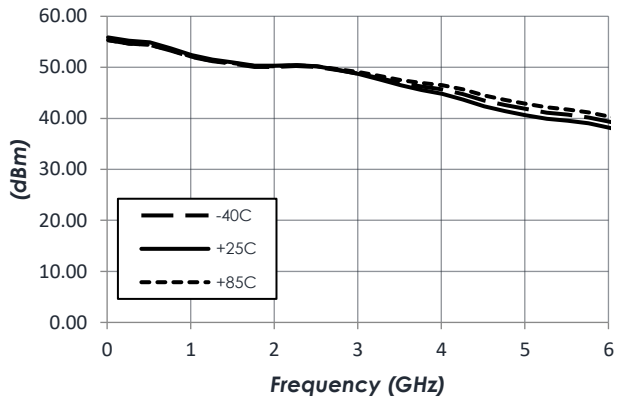

P1dB vs Temperature

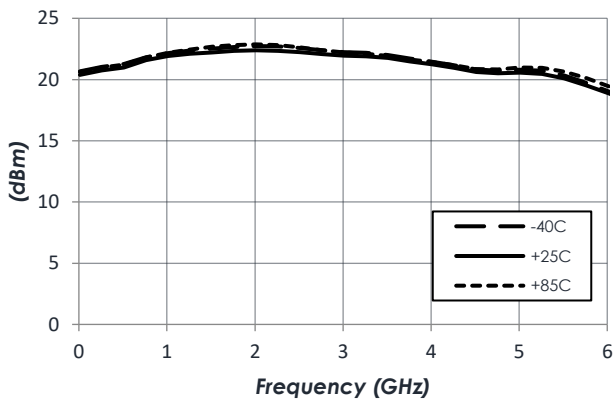

Reverse Isolation vs Temperature

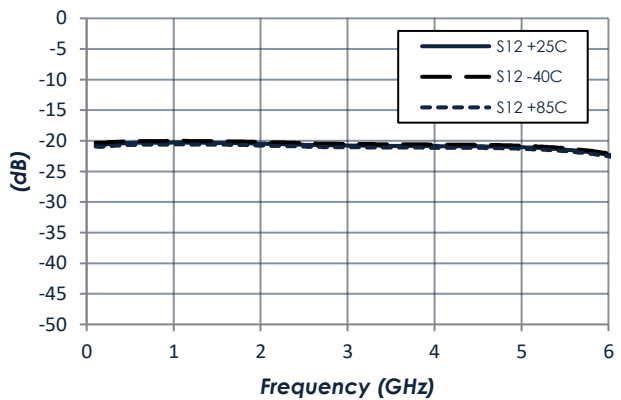

*Note: Measured with 2 tone test; tone spacing 10 MHz

TYPICAL PERFORMANCE (CONTINUED)

(VD = +5.0 V, Id = 112 mA)

P_{Sat} vs Temperature

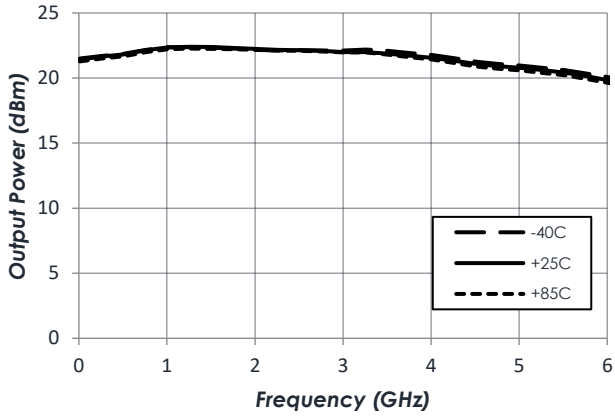

Pin vs. Pout at +25C

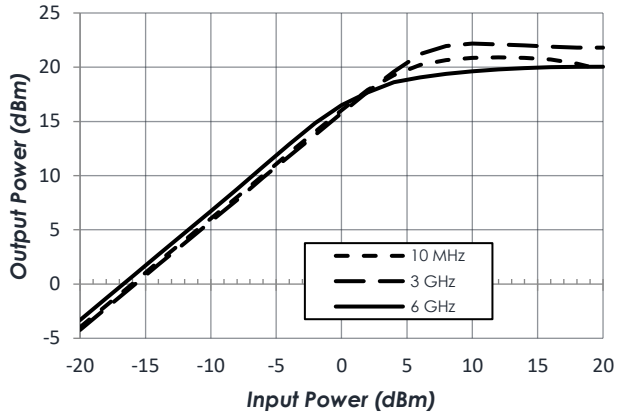

Pin vs. Pout at -40C

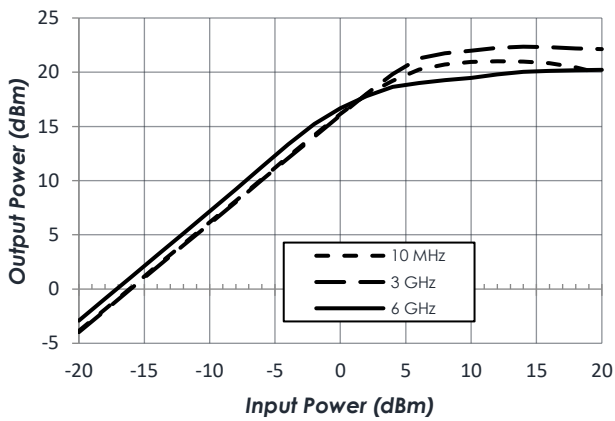

Pin vs. Pout at +85C

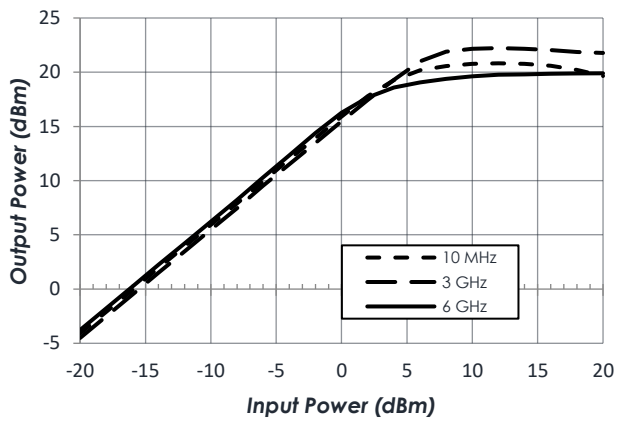

TYPICAL PERFORMANCE (CONTINUED)

(T = 25 °C unless otherwise specified)

Gain vs VD

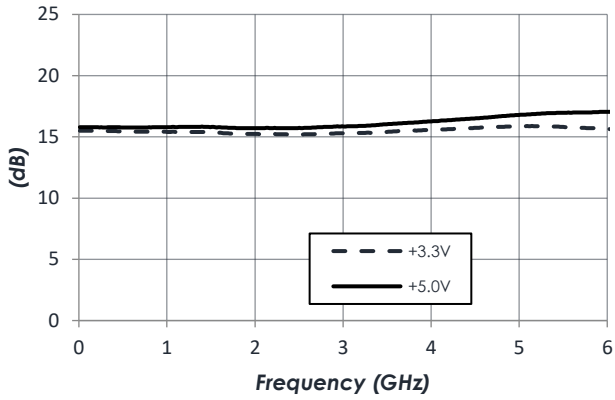

Noise Figure vs VD

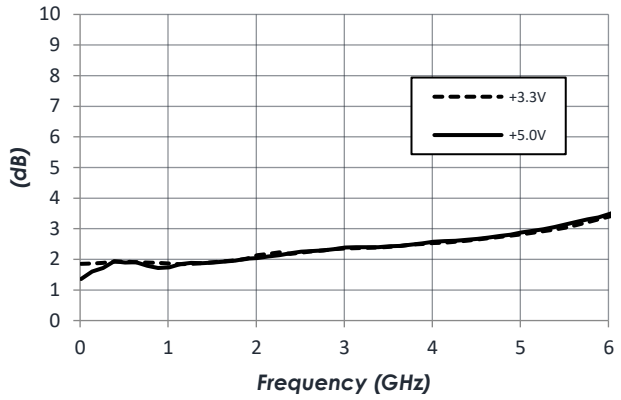

Output IP3 vs VD*

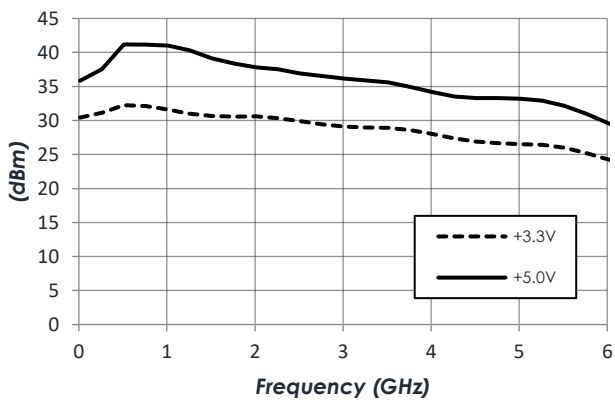

Output IP2 vs VD*

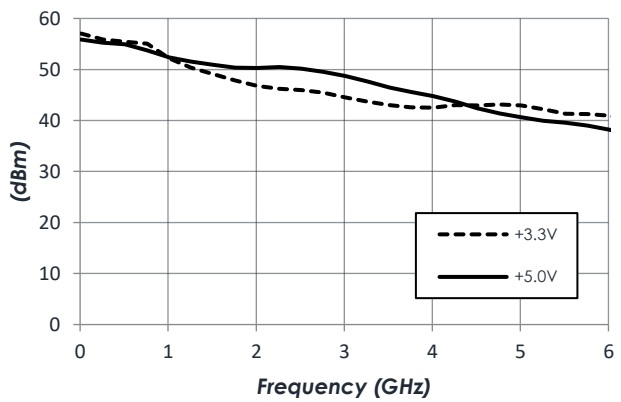

P1dB vs VD

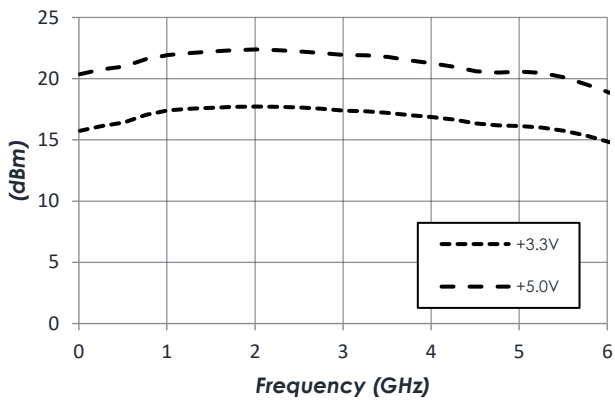

ID vs. VD

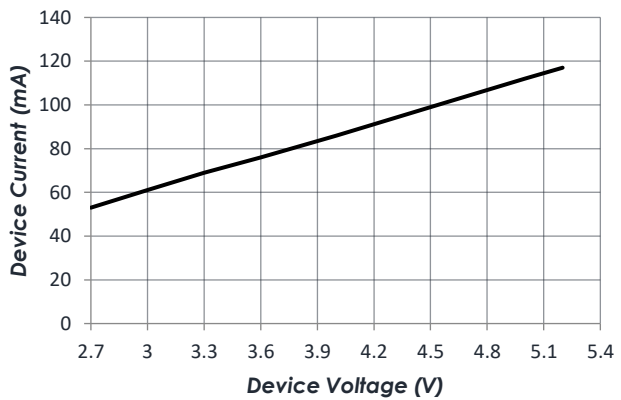

*Note: Measured with 2 tone test; tone spacing 10 MHz

TYPICAL APPLICATION

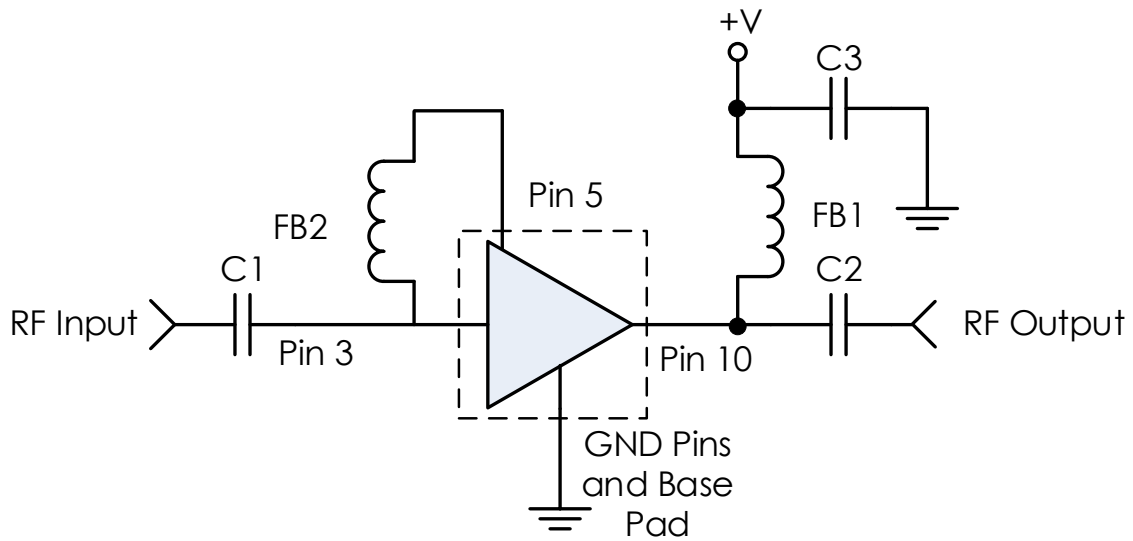

Recommended Component List (or Equivalent)

Part	Value	Part Number	Manufacturer
C1, C2	0.1 μ F	0402BB104KW160	Passives Plus
C3	0.1 μ F	GRM155R71C104KA88	Murata
FB1, FB2	-	MMZ1005A222E	TDK

Notes:

1. NC pins may be grounded or left open.
2. DC blocking capacitors should be high performance, low-loss, broadband capacitors for optimum performance.
3. FB1 and FB2 can be substituted for a different bead or inductor to extend performance lower in frequency.

EVALUATION PC BOARD

(Not all components shown will necessarily be installed)

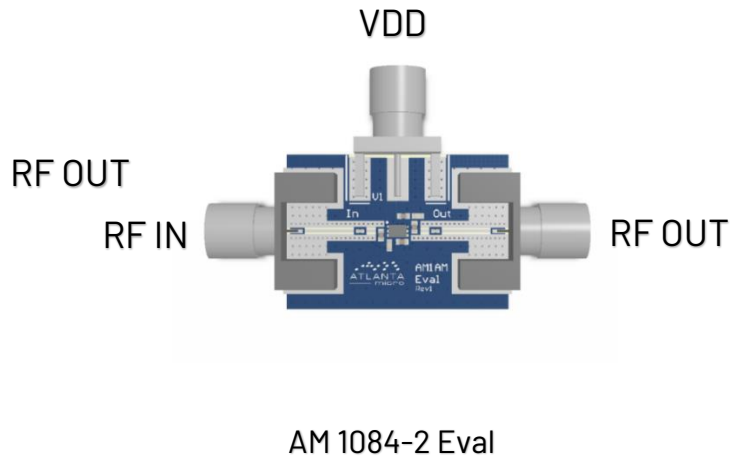
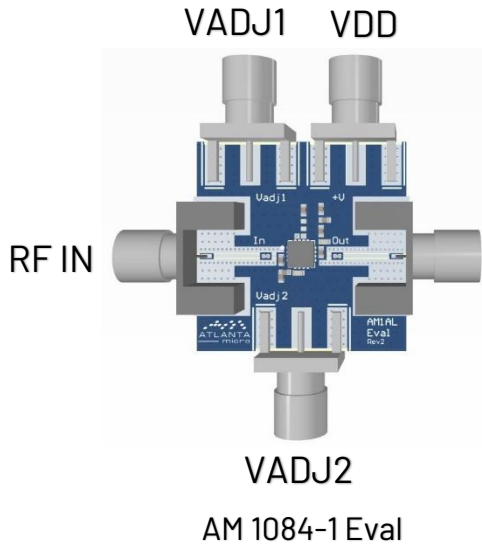

PART ORDERING DETAILS

Part Number	Description
AM1084-1	3mm 16 Lead QFN
AM1084-2	1.3mm x 2mm 6 Lead DFN
AM1084-1 Eval	AM1084-1 Evaluation Board
AM1084-2 Eval	AM1084-2 Evaluation Board
AM1084-M	AM1084-1 in 0.95" x 1.13" x 0.6" RF-Shielded Module with Integrated Bias Tee and Field Replaceable SMA Connectors

TECHNICAL DATA SHEET

RELATED PARTS

Part Number		Description
AM1016B	20 MHz to 6 GHz	+3.3V Gain Block
AM1018C	20 MHz to 6 GHz	+5.0V Gain Block
AM1025B	20 MHz to 3 GHz	+8.0V Gain Block (High P1dB)
AM1031C	20 MHz to 8 GHz	+3.3V Gain Block
AM1065	DC to 8 GHz	Bypassable Gain Block
AM1073	DC to 8 GHz	Bidirectional / Bypassable Gain Block
AM1085	DC to 6 GHz	+5.0V Gain Block
AM1090	DC to 6 GHz	+5.0V or +8.0V Gain Block
AM1163-1	DC to 10 GHz	Gain Block
AM1164-1	DC to 8 GHz	Gain Block

COMPONENT COMPLIANCE INFORMATION

RoHS: Mercury Systems, Inc. hereby certifies that all products comply with the EC Directive 2011/65/EC on the Restriction of Hazardous Substances, commonly known as EU-RoHS 6 and 10. All products supplied by Mercury shall be compliant with the European Directive 2011/65/EC based on the following substance list.

Substance List	Allowable Maximum Concentration
Lead (Pb)	<1000 PPM (0.1% by weight)
Mercury (Hg)	<1000 PPM (0.1% by weight)
Cadmium (Cd)	<75 PPM (0.0075% by weight)
Hexavalent Chromium (CrVI)	<1000 PPM (0.1% by weight)
Polybrominated Biphenyls (PBB)	<1000 PPM (0.1% by weight)
Polybrominated Diphenyl ethers (PBDE)	<1000 PPM (0.1% by weight)
Decabromodiphenyl Deca BDE	<1000 PPM (0.1% by weight)
Bis (2-ethylhexyl) Phthalate (DEHP)	<1000 PPM (0.1% by weight)
Butyl Benzyl Phthalate (BBP)	<1000 PPM (0.1% by weight)
Dibutyl Phthalate (DBP)	<1000 PPM (0.1% by weight)
Diisobutyl Phthalate (DIBP)	<1000 PPM (0.1% by weight)

REACH: Mercury Systems, Inc. neither uses nor intentionally adds any of the substances considered to be a Substance of Very High Concern (SVHC) as defined by the EU Regulation (EC) No. 1907-2006 on Registration, Evaluation, Authorization, and Restriction of Chemicals (REACH).

Conflict Materials: Mercury does not knowingly use materials that are sourced from the Democratic Republic of Congo (DRC) or any other known conflict regions. Mercury’s supply chain is comprised of sources that are both environmentally and socially responsible. We periodically review this requirement with our vendors to ensure continued compliance.

Mercury takes its responsibility as a global partner seriously and will use due diligence within our supply chain to ensure all standards are met to the best of our knowledge.



Corporate Headquarters

50 Minuteman Road
 Andover, MA 01810 USA
 +1 978.967.1401 tel
 +1 866.627.6951 tel
 +1 978.256.3599 fax

International Headquarters

Mercury International
 Avenue Eugène-Lance, 38
 PO Box 584
 CH-1212 Grand-Lancy 1
 Geneva, Switzerland
 +41 22 884 5100 tel

Learn more

Visit: mrcy.com

For pricing details, contact: MMICsales@mrcy.com

For technical details, contact: MMICsupport@mrcy.com



The Mercury Systems logo is a registered trademark of Mercury Systems, Inc. Other marks used herein may be trademarks or registered trademarks of their respective holders. Mercury products identified in this document conform with the specifications and standards described herein. Conformance to any such standards is based solely on Mercury’s internal processes and methods. The information contained in this document is subject to change at any time without notice.

