

SpectrumSeries™

RFM6101 Wideband Microwave Transceiver

Versatile and scalable 6U OpenVPX™ and OpenRFM™ architecture compliant

- RF coverage from 6 - 18 GHz
- 2 Rx down-converter channels and 2 Tx up-converter channels
- Rugged, compact and full open systems compliance
- Wideband - Excellent phase noise - High dynamic range
- Built-in LO generation - System lockable via external reference inputs
- External LOs capability for EW versatility

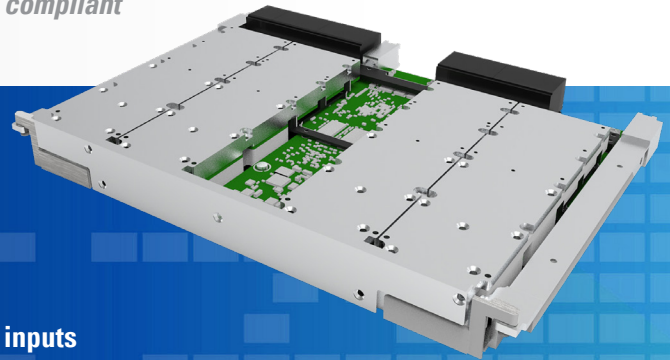

Mercury's SpectrumSeries RFM6101 is an ultra-wideband microwave transceiver with versatile local oscillator (LO), low-phase noise and fast tuning speed, packaged in a low-SWaP 6U module. Each compact module contains 2 down-converters and 2 up-converter providing maximum flexibility. These versatile transceivers are open system architecture compliant in both the digital and RF processing domains through OpenVPX (VITA 65) and OpenRFM.

Open system architecture for RF processing - OpenRFM

The challenges of digital and RF convergence, spectrum-fusion and maneuverability, complementary system interoperability and affordability are solved with OpenRFM. This open architecture approach standardizes and streamlines the design, integration, and testing of RF and digital capabilities within embedded processing subsystems. OpenRFM design principles are compatible with prevailing embedded computing industry standards.

OpenRFM™ ...

- standardizes the electromechanical, software, control plane and thermal interfaces used by integrated microwave assemblies (IMAs) to streamline the design and integration of RF and digital capabilities.
- is both modular and scalable in its approach to design, test, and control plane practices for interfacing RF and digital subsystems within embedded architectures and is wholly interoperable with ANSI/VITA standards including 3U and 6U OpenVPX and VME/VXS.
- defines standard interfaces and leverages IP re-use across applications to drive overall investment value, efficient SWaP-C utilization and expedited time-to-solution/market.

SpectrumSeries subsystem building blocks

Mercury's SpectrumSeries OpenRFM transceivers, processing and A/D conversion building blocks are easily integrated into low-risk, turnkey, real-time signal processing subsystems. These subsystems comprise of complete receiver/analysis solutions for communication and electronic intelligence enabling practitioners to react quickly from resulting information.

Mercury Systems is a leading commercial provider of secure processing subsystems designed and made in the USA. Optimized for customer and mission success, Mercury's solutions power a wide variety of critical defense and intelligence programs.



ACQUIRE



DIGITIZE



PROCESS



STORAGE



EXPLOIT



DISSEMINATE

Signal collection, digitization and processing domain expertise

Mercury leverages 35 years of high-frequency, wide-bandwidth signal acquisition, digitizing and decimation experience to produce performance optimized and balanced RF processing subsystems. We commit our proven hardware and software expertise to interoperable, scalable open system building blocks that minimize risk and leverage the best commercial technology to drive performance and affordability. Our application and system engineers integrate these proven building blocks in to sophisticated EW processing subsystems that can be refreshed at the speed of technology.

Specifications

Packaging

Format/size	6U OpenVPX, single slot
Power	95W Maximum
Control interface	1GbE (consult factory for more options)
Weight	<2kg (rugged air-cooled)

Commercial and rugged air-cooled or rugged conduction cooled

OpenRFM interoperability

RF Down converter specifications

RF input coverage	6GHz to 18GHz
Noise figure	14 dB typical (16 dB max)
Gain (max RF to IF)	20 dB
Max RF (without damage)	20dBm
OP1dB (with max gain)	15dBm
OIP3 (with max gain)	27dBm
Attenuation	31dB in .5 dB steps
Linear dynamic range	91dB (with 1MHz BW)
Single-tone, signal related spurious	-60dBc (@ -15dBm Input)
Single-tone, internally generated spurious	-80dBc (@ -15dBm Input)
IF output center frequency*	1.875GHz
IF bandwidth	1.375GHz to 2.375GHz
IF band flatness	+/-1.5dB typical
Tuning speed	25 µsecs typical (To within 10 kHz)
Tuning resolution	10MHz
VSWR (In/out)	2:1
IF Rejection	-70dBc
Image Rejection	-70dBc
LO Leakage	-80dBm typ (-70dBm max)

RF UP CONVERTER SPECIFICATIONS

RF output coverage	6GHz to 18GHz
Noise figure	20dB typical
Gain (max IF to RF)	20dB
OP1dB (with max gain)	21dBm
OIP3 (with max gain)	30dBm
Attenuation	31dB in 0.5dB steps
Single-tone, signal related spurious	-55dBc (@ -10dBm input and max gain)
Single-tone, internally generated spurious	-80dBm(@ -10dBm input and max gain)
IF input center frequency**	1.875GHz
IF bandwidth	1.375GHz to 2.375GHz
IF band flatness	+/-1.5dB
Tuning speed	25 µsecs typical (To within 10 kHz)
Tuning resolution	10MHz
VSWR (In/out)	2:1

Native LO generation specifications

Reference Input	10MHz – 100MHz; 100MHz preferred
Composite phase noise***	
100 Hz	-70 dBc/Hz
1 kHz	-80 dBc/Hz
10 kHz	-90 dBc/Hz
100 kHz	-95 dBc/Hz
1 MHz	-99 dBc/Hz
10 MHz	-125 dBc/Hz
20 MHz	-130 dBc/Hz
100 MHz	-133 dBc/H

* The IF output has a direct mode that allows 100MHz to 6 GHz to be routed directly to the IF output bypassing the RF translation chain and IF Filters.

** The IF input has a direct mode that allows 100MHz to 6 GHz to be routed directly to the RF output bypassing the RF translation chain and IF Filters.

*** Phase noise is based upon a 100MHz clean reference, such as OCXOs used for system references.

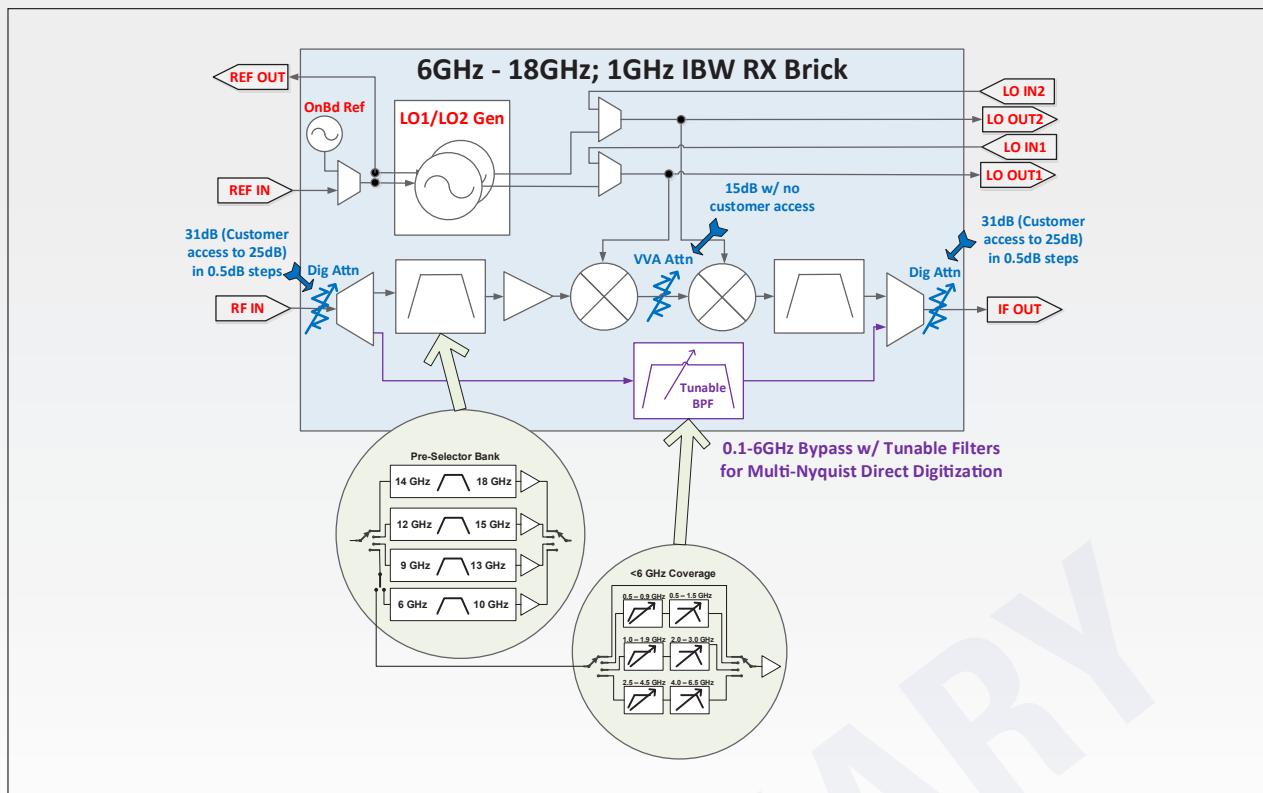

Figure 1. RFM6101 Rx Filtering Block Diagram

Environmental

		Environmental Qualification Levels		
		Air-cooled		Conduction-cooled
		Commercial L0	Rugged L1	Rugged L3
Ruggedness		•	••	•••
Moisture/dust protection		•	••	•••
Temperature	Operating*	0°C to +40°C	-25°C to +55°C	-40°C to +71°C
Operating temperature maximum rate of change		N/A	5°C/min	10°C/min
Temperature	Storage	-40°C to +85°C	-55°C to +85°C	-55°C to +125°C
Humidity	Operating*	10-90%, non-condensing	5-95%, non-condensing	5-95%, non-condensing, 100% condensing
	Storage	10-90%, non-condensing	5-95%, non-condensing	5-95%, non-condensing, 100% condensing
Altitude	Operating*	0-10,000ft	0-30,000ft	0-70,000ft
	Storage	0-30,000ft	0-50,000ft	0-70,000ft
Vibration	Random	0.003 g ² /Hz; 20-2000 Hz, 1 hr/axis	0.04 g ² /Hz; 20-2000 Hz, 1 hr/axis	0.1 g ² /Hz; 5-2000 Hz, 1 hr/axis
	Sine	N/A	N/A	10G peak; 5-2000 Hz, 1 hr/axis
	Shock	z-axis: 20g; , x and y-axes: 32g; (11ms 1/2-sine pulse, , 3 positive, 3 negative)	z-axis: 50g; , x and y-axes: 80g; (11ms 1/2-sine pulse,, 3 positive, 3 negative)	z-axis: 50g; , x and y-axes: 80g; (11ms 1/2-sine pulse, , 3 positive, 3 negative)
Salt/Fog		N/A	Contact Factory	10% NaCl
VITA 47			Contact Factory	

* Customer must maintain required cfm level. Consult factory for the required flow rates.

** Card edge should be maintained below 71°C

Storage Temperature is defined per MIL-STD-810F, Method 502.4, para 4.5.2, where the product under non-operational test is brought to an initial high temperature cycle to remove moisture. Then the unit under non-operational test will be brought to the low storage temperature. The low temperature test is maintained for 2 hours. The product is then brought to the high storage temperature and is maintained for 2 hours. The product is then brought back to ambient temperature. All temperature transitions are at a maximum rate of 10°C/min. One cold/hot cycle constitutes the complete non-operational storage temperature test. This assumes that the board level products are individually packaged in accordance with ASTM-D-3951 approved storage containers. These tests are not performed in Mercury shipping containers, but in an unrestrained condition. Please consult the factory if you would like additional test details.

All products manufactured by Mercury meet elements of the following specifications: MIL-STD-454, MIL-STD-883, MIL-HDBK-217F, and MIL-I-46058 or IPC-CC-830, and various IPC standards. Mercury's inspection system has been certified in accordance with MIL-I-45208A.

Additional Services			
Optional Environmental Screening and Analysis Services		Standard Module, Optional Services	
• Cold Start Testing	• Safety Margin Analysis	• Engineering Change Order (ECO) Notification	• Alternate Mean Time Between Failure (MTBF) Calculations
• Cold Soak Testing	• Temperature Cycling	• ECO Control	• Hazmat Analysis
• Custom Vibration	• Power Cycling	• Custom Certificate of Conformity (CofC)	• Diminished Manufacturing Sources (DMS) Management
• CFD Thermal Analysis	• Environmental Stress Screening	• Custom UID Labeling	• Longevity of Supply (LOS)
• Finite Element Analysis			• Longevity of Repair (LOR)
Contact factory for additional information			

PRELIMINARY

The Mercury Systems logo and the following are trademarks or registered trademarks of Mercury Systems, Inc.: Mercury Systems, Innovation That Matters, SpectrumSeries, and OpenRFM. Other marks used herein may be trademarks or registered trademarks of their respective holders. Mercury believes this information is accurate as of its publication date and is not responsible for any inadvertent errors. The information contained herein is subject to change without notice. Copyright © 2020 Mercury Systems, Inc. 5033.01E-0220-ds-RFM6101



INNOVATION THAT MATTERS®

CORPORATE HEADQUARTERS

50 Minuteman Road • Andover, MA 01810 USA
(978) 967-1401 • (866) 627-6951 • Fax (978) 256-3599

EUROPE MERCURY SYSTEMS, LTD

Unit 1 - Easter Park, Benyon Road, Silchester, Reading
RG7 2PQ United Kingdom
+ 44 0 1189 702050 • Fax + 44 0 1189 702321

