

Secure Solid State Drives (SSD)

Mercury TRRUST-Stor[®] MissionPak



19-pin Model: *MMSxxxAM6x-000lxx-01, (SATA, Short)*
MMSxxxAM6x-000lxx-02, (NVMe, 1-Lane, Short)
MMLxxxAM6x-000lxx-03, (NVMe, 2-Lane, Long)

7-pin Model: *MMRxxxAM6S-000lxx-01 (SATA SLC mode)*
MMRxxxAM6T-000lxx-01 (SATA TLC mode)



- Engineered to CSfC, FIPS 140-2, and Common Criteria (CC) requirements (Planned)
- SATA and NVMe models
- Supports all popular military sanitized protocols plus self-destruct
- AES-256 XTS encryption with user fillable keys
- Heavily ruggedized, water-resistant form-factor



ADVANCED*

The Mercury TRRUST-Stor MissionPak SSD series expands the concept of hand-held storage to new frontiers by integrating the latest generation Armor™ NAND processor with AES-256 XTS encryption, multiple key management modes, DS-101 key fill, and self-destruct capability into an ergonomically packaged water-resistant form-factor designed for ease of use in harsh, possibly insecure environments.

Featuring the latest generation 3D NAND, TRRUST-Stor MissionPak is available in extended capacity TLC models and extended-life SLC-mode models. It includes the security and certifications of the popular ASURRE-Stor[®] SSD, in a heavily ruggedized, water-resistant ultra-portable form-factor. With options for either SATA or NVMe, TRRUST-Stor MissionPak is the perfect choice for mission critical applications where reliability, security, and ruggedization are the key to mission success.

Features

- Designed and manufactured in the secure DMEA-accredited facility
- Mercury proprietary Armor 6 NAND processor
- Third generation 3D NAND flash technology.
 - TLC models (extended capacity) and SLC models (extended-life)
- Host usable capacity
 - SLC model: 128, 256, 512** GB¹
 - TLC model: 384, 768, 1536** GB
 - **Long form factor only
- Total Bytes Written (TBW)
 - 7.7 PB (512 GB SLC mode)
 - 3.8 PB (1536 GB TLC mode)

*This product is under development, is not qualified or characterized and is subject to change or cancellation without notice.

Mercury Systems is a leading commercial provider of secure sensor and safety-critical processing subsystems. Optimized for customer and mission success, Mercury's solutions power a wide variety of critical defense and intelligence programs.

- FIPS 140-2 and CSfC certified models F and C suffix (planned)
 - Compliant to the NIAP EE and AA protection profiles
 - User and Crypto Officer Roles
- Multiple key management modes including user TRRUST-Boot secure boot image
- AES Key-Flipper technology eliminates key burn-in
- Fast Clear: Less than 10 seconds
- SKL and CYZ-10 compatible (19-pin model)
- Sequential Read/Write performance: Up to 1000 MB/s²
- Ultra-strong LDPC Hard/Soft Error Correction
- UBER (Uncorrectable Bit Error Rate): 10⁻¹⁸
- Ruggedized water-resistant potted enclosure
- Hot Swap capable
- MTBF: 2 million hours @ 25 °C, Telcordia
- Vibration: 40.0 Grms, 15-2000 Hz, 3 axes, 6 hrs
- Operating shock: 3000 G, 0.5 ms, ½ sine
100 G, 11 ms, ½ sine
- Operating Temperature: -40 °C to +85 °C³
Boot Holdoff from -55 °C to -40 °C
- Storage Temperature: -55 °C to +105 °C³
- Humidity: 100% condensing. Water immersion to 2 feet for 10 minutes.
- Altitude: 80,000 feet
- Weight: 80 grams
- Single 3.3 to 5.5 V ± 5% supply

NOTES:

1. One Gigabyte (GB) = 1,000,000,000 bytes.
100 MB/s = 100,000,000 bytes per second.
2. Performance values based on 128 KiB sequential transfers and largest capacity model.
3. Data retention may diminish with extended storage or operation at temperatures above 70 °C. Operation at 85 °C requires maintaining Tcase at 85 °C or less.

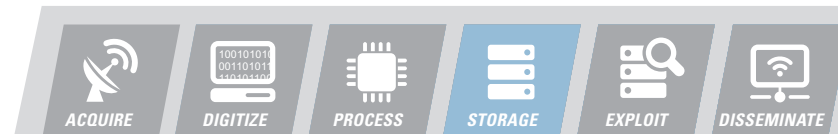

Typical Applications



Product Dimensions (in millimeters)

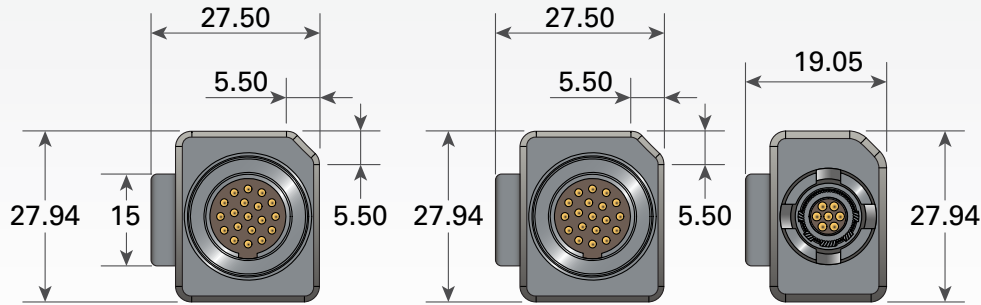

The host side "plug" connector is available from [Spacecraft Connectors Corp. KwikSnap Series \(SCTAC\)](http://Spacecraft Connectors Corp. KwikSnap Series (SCTAC)).

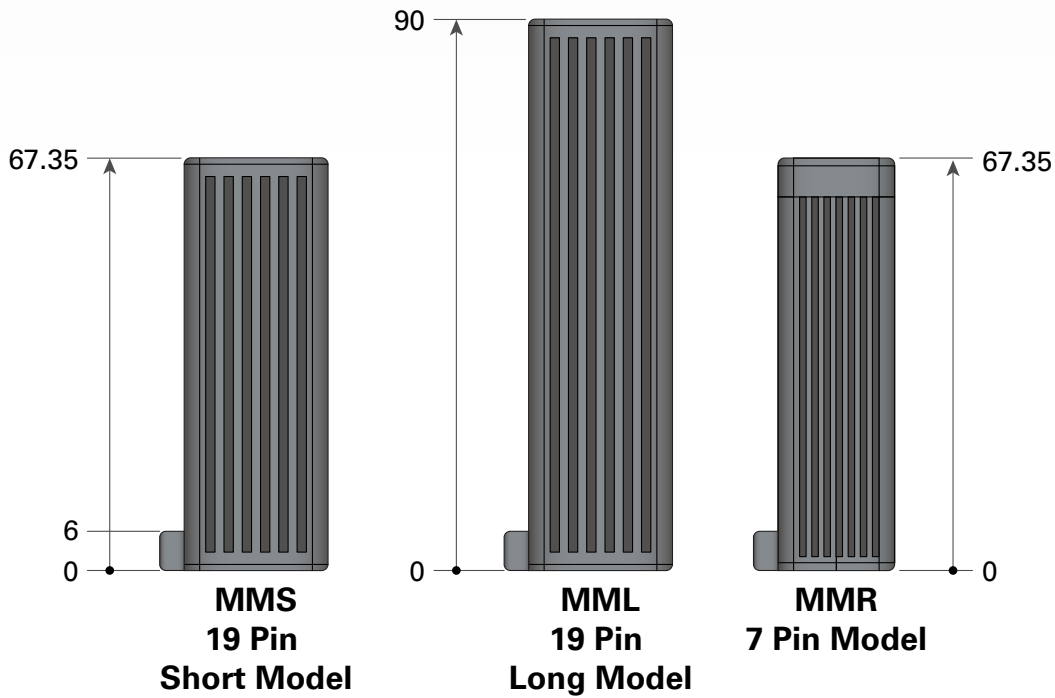

MML, MMS – 19 Pin Model

Pinout on 19 pin Receptacle
TX pin names are outputs from MissionPak
RX pin names are inputs to MissionPak

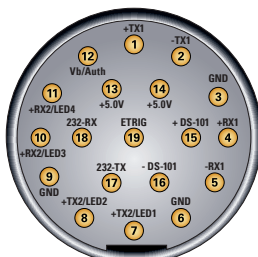

Drawing not to scale.

MMR – 7 Pin Model

Pinout on 7 pin Receptacle
TX pin names are outputs from MissionPak
RX pin names are inputs to MissionPak



Drawing not to scale.

Part Numbering *(dashes in the part number are required)*

X XX xxx X M x m - 123 I xx - aa

Product Series

- M = TRRUST-Stor® series, standard model without FIPS 140-2, Common Criteria or CSfC certifications
- A = ASURRE-Stor® certified series with FIPS 140-2, and Common Criteria certifications. Eligible for use in CSfC 2-layer encryption solutions upon certification

Form Factor

- ML = MissionPak (SATA/NVMe, 19-Pin Long Model)
- MS = MissionPak (SATA/NVMe, 19-Pin Short Model)
- MR = MissionPak (SATA, 7-Pin Short Model)

NAND (Capacity available to Host)

- xxx = 128, 256, 512* GB SLC mode
384, 768, 1536* GB TLC mode
*Long form factor only

Encryption Type

- A = AES-256 XTS
- Q = Post Quantum (Planned)
- V = SuiteA (Sponsored)
- N = No Encryption

Media

- M = Standard product

Media Type

- 2 = 1-bit SLC NAND, 32Gb
- 6 = 3-bit TLC 3D NAND

Operating Mode

- S = SLC mode
- T = TLC mode

-

Customizable Features fields One, Two and Three

- G00 = Standard product, gray
- B00 = Standard product, black

Operating Temperature

- I = Industrial (-40 °C to +85 °C)
- C = Commercial (0 °C to 70 °C)

Classification

- ES = Engineering Sample
- C = CC and FIPS-140-2 certified; CSfC component listed upon qualification
- F = FIPS-140-2 certified
- 00 = Standard product

-

Attributes

- 01 Construction: Lead Free (R)
Interface Structure: 1 Lane (1)
Interface Type: SATA 6 Gb/s (SA)
- 02 Construction: Lead Free (R)
Interface Structure: 1 Lane (1)
Interface Type: NVME (NV)
- 03 Construction: Lead Free (R)
Interface Structure: 2 Lane (2)
Interface Type: NVME (NV)
- 04 Construction: Leaded (L)
Interface Structure: 1 Lane (1)
Interface Type: SATA 6 Gb/s (SA)

Example part Number: MML512AM6S-000I00-01 (SATA, Long, 512 GB, SLC)

Need More Help? Need a Variant of This Product?

Contact Mercury's Secure SSD application engineering team at secure.ssd@mrcy.com



Download our
Secure SSD Tech Brief



Download our
Demystifying Hardware
Full Disk Encryption
Technology for Military
Data Storage



Download our
Safeguarding Mission
Critical Data Whitepaper



Download our
Microelectronics
Quick Reference Guide

TRRUST-Stor and ASURRE-Stor are a registered trademarks, BuiltSECURE, Innovation That Matters, and Mercury Systems are trademarks of Mercury Systems, Inc. Other product and company names mentioned may be trademarks and/or registered trademarks of their respective holders. Mercury Systems, Inc. believes this information is accurate as of its publication date and is not responsible for any inadvertent errors. The information contained herein is subject to change without notice.

Copyright © 2018 Mercury Systems, Inc.

5021.13E 0918 ds SSD Mercury TRRUST-Stor MissionPak RMM



CORPORATE HEADQUARTERS
50 Minuteman Road
Andover, MA 01810-1008 USA
+1 (978) 967-1401
+1 (866) 627-6951
Fax +1 (978) 256-3599

MICROELECTRONIC SECURE SOLUTIONS
3601 East University Drive
Phoenix, AZ 85034-7217 USA
+1 (602) 437-1520
Fax +1 (602) 437-1731

